



990DSL

CopperPro Loop Tester

Users Guide

PN 1554870

September 2001, Rev 3, 3/04

© 2001-2004 Fluke Networks, Inc. All rights reserved. Printed in USA
All product names are trademarks of their respective companies.

LIMITED WARRANTY & LIMITATION OF LIABILITY

Each Fluke Networks product is warranted to be free from defects in material and workmanship under normal use and service. The warranty period is one year and begins on the date of purchase. Parts, accessories, product repairs and services are warranted for 90 days. This warranty extends only to the original buyer or end-user customer of a Fluke Networks authorized reseller, and does not apply to disposable batteries, cable connector tabs, cable insulation-displacement connectors, or to any product which, in Fluke Networks' opinion, has been misused, altered, neglected, contaminated, or damaged by accident or abnormal conditions of operation or handling. Fluke Networks warrants that software will operate substantially in accordance with its functional specifications for 90 days and that it has been properly recorded on non-defective media. Fluke Networks does not warrant that software will be error free or operate without interruption.

Fluke Networks authorized resellers shall extend this warranty on new and unused products to end-user customers only but have no authority to extend a greater or different warranty on behalf of Fluke Networks. Warranty support is available only if product is purchased through a Fluke Networks authorized sales outlet or Buyer has paid the applicable international price. Fluke Networks reserves the right to invoice Buyer for importation costs of repair/replacement parts when product purchased in one country is submitted for repair in another country.

Fluke Networks' warranty obligation is limited, at Fluke Networks' option, to refund of the purchase price, free of charge repair, or replacement of a defective product which is returned to a Fluke Networks authorized service center within the warranty period.

To obtain warranty service, contact your nearest Fluke Networks authorized service center to obtain return authorization information, then send the product to that service center, with a description of the difficulty, postage and insurance prepaid (FOB Destination). Fluke Networks assumes no risk for damage in transit. Following warranty repair, the product will be returned to Buyer, transportation prepaid (FOB Destination). If Fluke Networks determines that failure was caused by neglect, misuse, contamination, alteration, accident or abnormal condition of operation or handling, or normal wear and tear of mechanical components, Fluke Networks will provide an estimate of repair costs and obtain authorization before commencing the work. Following repair, the product will be returned to the Buyer transportation prepaid and the Buyer will be billed for the repair and return transportation charges (FOB Shipping Point).

THIS WARRANTY IS BUYER'S SOLE AND EXCLUSIVE REMEDY AND IS IN LIEU OF ALL OTHER WARRANTIES, EXPRESS OR IMPLIED, INCLUDING BUT NOT LIMITED TO ANY IMPLIED WARRANTY OF MERCHANTABILITY OR FITNESS FOR A PARTICULAR PURPOSE. FLUKE NETWORKS SHALL NOT BE LIABLE FOR ANY SPECIAL, INDIRECT, INCIDENTAL OR CONSEQUENTIAL DAMAGES OR LOSSES, INCLUDING LOSS OF DATA, ARISING FROM ANY CAUSE OR THEORY.

Since some countries or states do not allow limitation of the term of an implied warranty, or exclusion or limitation of incidental or consequential damages, the limitations and exclusions of this warranty may not apply to every buyer. If any provision of this Warranty is held invalid or unenforceable by a court or other decision-maker of competent jurisdiction, such holding will not affect the validity or enforceability of any other provision.

Fluke Networks, Inc.
PO Box 777
Everett, WA 98206-0777
USA

Table of Contents

Chapter	Title	Page
1	Introduction.....	1-1
	Using This Guide.....	1-1
	Introduction.....	1-2
	Design Highlights and Features of the CopperPro.....	1-3
	Physical Features.....	1-3
	User Interface Features.....	1-3
	Testing Features.....	1-4
	Safety Information.....	1-5
	Care and Maintenance.....	1-8
	Service and Adjustment.....	1-8
	Checking the Shipping Container.....	1-9
	Technical Support.....	1-11
2	Controls and Connections.....	2-1
	Introduction.....	2-1
	The CopperPro Loop Tester: at a Glance.....	2-2
	Front Panel.....	2-2
	LCD.....	2-3
	Keypad.....	2-3
	Top Connector Panel.....	2-6
	Side Connector Panel.....	2-6
	Back Panel.....	2-7
	Connecting the CopperPro.....	2-8
	Connecting to AC Power.....	2-8
	Connecting to an Automobile Battery.....	2-8
	Connecting to a Printer.....	2-9
	Connecting to a PC.....	2-9
	The Battery.....	2-10
	Checking the Remaining Battery Capacity.....	2-10
	Responding to Low Battery Warnings.....	2-11
	Charging the Battery.....	2-11
	Discharging Battery.....	2-13
3	Setting Up and Operating the CopperPro.....	3-1

Introduction.....	3-1
Turning the CopperPro On and Off.....	3-2
The Menus	3-3
Displaying the Main Menu.....	3-3
Displaying the Previous Menu or Screen.....	3-4
Displaying a Setup Menu.....	3-4
Auto-Test Setup Menu.....	3-5
Toolbox Test Setup Menu.....	3-5
Generic and Test-Specific Setup Parameters.....	3-5
Editing the Setup for a Test.....	3-7
Configuring the Tester.....	3-10
Function Keys.....	3-10
Setting the Date and Time.....	3-11
Setting a Timer to Conserve Power.....	3-12
Selecting a Language and Associated Units of Measure.....	3-13
Creating a Phone List.....	3-14
Storing the Serial Number and Property Information.....	3-16
Configuring the Serial Port.....	3-17
Creating a Custom Header for Test Result Files.....	3-17
Performing Basic Operations.....	3-20
Calibrating the CopperPro.....	3-20
Turning the Backlight On and Off.....	3-21
Adjusting the Contrast of the LCD.....	3-21
Adjusting the Volume of the Speaker.....	3-22
Displaying System Information.....	3-22
Operating the Tester as a Dial Set.....	3-23
Running a Self-Test.....	3-24
Printing Displayed Results and Setup Information.....	3-24
Transferring a Screen Image to a PC.....	3-25
4 POTS Testing and Fault Location.....	4-1
Introduction.....	4-1
POTS Auto-Test.....	4-2
Setting Up a POTS Auto-Test.....	4-2
Starting and Stopping a POTS Auto-Test.....	4-6
POTS Auto-Test Results.....	4-6
Saving POTS Auto-Test Results.....	4-7
The POTS Toolbox.....	4-8
Starting and Stopping a Test in the POTS Toolbox.....	4-8
Voltage Test.....	4-8
Setting Up a Voltage Test.....	4-9
Voltage Test Results.....	4-10
Shorts & Grounds Test.....	4-12
Setting Up a Shorts & Grounds Test.....	4-12
Shorts & Grounds Test Results.....	4-12
Opens Test.....	4-15
Setting Up an Opens Test.....	4-15
Opens Test Results.....	4-16

Splits Test	4-19
Resistance Fault Location (RFL) Test	4-22
Setting Up an RFL Test	4-22
Running an RFL Test	4-23
RFL Test “Distance to Strap” Entry	4-29
Short or Double-Sided Fault Location (3 Wire) Test Results	4-30
RFL Test: K-Test Option	4-33
K-Test Pair Requirements	4-33
Running the K-Test	4-34
Load Coils Test	4-35
Setting Up a Load Coils Test	4-35
Load Coils Test Results	4-35
Loop Devices Test	4-37
Setting Up a Loop Devices Test	4-37
Loop Devices Test Results	4-38
Leakage Stress Test	4-38
Setting Up a Leakage Stress Test	4-38
Leakage Stress Test Results	4-39
Tracing Tone Test	4-40
Setting Up a Tracing Tone Test	4-40
Running a Tracing Tone Test	4-40
VF Noise Test	4-41
Setting Up a VF Noise Test	4-41
VF Noise Test Results	4-41
Power Harmonics Test	4-43
VF Loss Test	4-44
Setting Up a VF Loss Test	4-44
Running a VF Loss Test	4-45
VF Loss Test Results	4-46
VF Longitudinal Balance Test	4-47
Setting Up a VF Longitudinal Balance Test	4-47
VF Longitudinal Balance Test Results	4-47
Send VF Tone Test	4-48
Setting Up a Send VF Tone Test	4-48
Running a Send VF Tone Test	4-49
Running a Send VF Tone Test	4-49
Loop Current & Ground Ohms Test	4-51
Setting Up a Loop Current & Ground Ohms Test	4-51
Running a Loop Current & Ground Ohms Test	4-52
Dial-Up Test Group	4-53
Setting Up a Dial-Up Test	4-54
Running a Dial-Up Test	4-55
Running a Milliwatt VF Loss Test	4-57
Running a Quiet Term. VF Noise Test	4-57
Running a VF Longitudinal Balance Test	4-58
Running a Number ANI Test	4-58
Running an On-Hook Caller ID Test	4-59
Running a Call Waiting Caller ID Test	4-60
Running a Line Monitor Function	4-60

Smart-Pro Tests.....	4-61
SASS Tests.....	4-64
DATU Tests.....	4-65
Terminated VF Tests.....	4-67
Setting Up a Terminated VF Test.....	4-67
Running a Terminated VF Test.....	4-68
Saving Terminator VF Auto-Test Results.....	4-70
Using the CopperPro as a Terminator.....	4-71
Manually Controlling a Far-End Terminator.....	4-72
5 XDSL Testing and Loop Qualification.....	5-1
Introduction.....	5-1
DSL Auto-Test.....	5-2
Running a DSL Auto-Test.....	5-7
DSL Auto-Test Results: ADSL Service Type.....	5-9
Disturber Mask Overlays.....	5-11
DSL Auto-Test Results: ALL Service Types.....	5-12
Saving DSL Auto-Test Results.....	5-13
ADSL Verify Test.....	5-14
Setting up an ADSL Verify Test.....	5-14
Running an ADSL Verify Test.....	5-14
ATU-C Test.....	5-15
ATU-C Test Results.....	5-15
ATU-R Test.....	5-16
ATU-R Test Results.....	5-16
The XDSL Toolbox.....	5-17
Starting and Stopping a Test in the XDSL Toolbox.....	5-18
WB Noise/Level Test.....	5-19
Setting Up a WB Noise/Level Test.....	5-19
WB Noise/Level Test Results for a Spare Pair.....	5-20
WB Noise/Level Test Results for a Working ADSL Pair.....	5-21
WB Loss Test.....	5-22
Setting Up a WB Loss Test.....	5-23
Running a WB Loss Test.....	5-23
WB Longitudinal Balance Test.....	5-24
Setting Up a WB Longitudinal Balance Test.....	5-24
Running a WB Longitudinal Balance Test.....	5-25
WB Longitudinal Balance Test Results.....	5-25
Send WB Tone Function.....	5-26
Setting Up a Send WB Tone Test.....	5-26
Running a Send WB Tone Test.....	5-27
ADSL Auto-Test.....	5-27
Setting Up an ADSL Auto-Test.....	5-27
Running an ADSL Auto-Test.....	5-28
ADSL Auto-Test Results.....	5-29
Terminated WB Tests.....	5-30
Setting Up a Terminated WB Test.....	5-30
Running a Terminated WB Test.....	5-30

Saving Terminated WB Test Results	5-31
Impulse Noise Test	5-32
Setting Up an Impulse Noise Test	5-32
Running an Impulse Noise Test	5-32
Impulse Noise Test Results	5-33
6 TDR Testing and Fault Location.....	6-1
Introduction	6-1
Comparing Parametric Tests to the TDR Test	6-2
What Happens During a TDR Test: An Overview	6-3
Length Measurements and VOP	6-3
Reflections	6-4
TDR Auto-Test	6-4
Setting Up a TDR Auto-Test	6-5
Starting and Stopping a TDR Auto-Test	6-6
TDR Auto-Test Results	6-7
The TDR Toolbox	6-11
Starting and Stopping a Test in the TDR Toolbox	6-12
Saving TDR Test Results	6-12
Pair 1 Test	6-12
Pair 1 and 2 Compare Test	6-13
Pair 1 - 2 Difference Test	6-14
Pair 1 Monitor	6-15
Pair 2 to 1 Crosstalk Test	6-16
Displaying and Deleting Saved Traces	6-17
Compare Recall and Pair 1 Test	6-17
TDR Test Operating Tips	6-18
Determining the VOP	6-18
Double-ended Testing	6-19
Testing for Faults Close to the CopperPro	6-20
7 Saved Test Results.....	7-1
Introduction	7-1
Saving Test Results	7-1
Storage Limitations of Saved Result Files	7-1
Result File Header	7-2
Storing Test Results Automatically	7-4
Saving a Displayed Waveform or Frequency Graph	7-5
Viewing Stored Test Results	7-6
Viewing Text-based Results	7-6
Viewing All Results	7-7
Viewing Results for a Particular Wire Center	7-8
Viewing Results for a Particular Period of Time	7-8
Erasing All Results	7-9
Viewing TDR Waveforms	7-9
Deleting a Saved Waveform	7-10
Viewing Stored a Frequency Sweep Graph	7-10
Deleting a Saved Frequency Graph	7-11
Printing Test Results	7-11

Uploading Test Results to a PC.....	7-12
8 Updating the CopperPro with New Software.....	8-1
Introduction.....	8-1
Before You Begin	8-2
Step One: Connect the Tester to a PC	8-2
Step Two: Put the Tester in Download Mode	8-2
Step Three: Updating the Tester’s Software	8-3
Appendices	
A Features and Specifications.....	A-1
B Replacement Parts and Accessories	B-1

Index

List of Tables

Table	Title	Page
1-1.	International Electrical Symbols	1-7
2-1.	Functions of the CopperPro Keys	2-3
3-1.	Generic Setup Parameters	3-7
3-2.	Operating the Tester in Edit Mode	3-9
4-1.	User Selectable Tests for the POTS Auto-Test	4-4
4-2.	Voltage Test Setup Parameters	4-9
4-3.	Shorts & Grounds Test Setup Parameters	4-12
4-4.	Opens Test Setup Parameters	4-15
4-5.	RFL Test Setup Parameters	4-22
4-6.	Leakage Stress Test Setup Parameter	4-38
4-7.	VF Noise Test Setup Parameters	4-41
4-8.	VF Loss Setup Parameter	4-44
4-9.	VF Longitudinal Balance Setup Parameters	4-47
4-10.	VF Tone Test Setup Parameter	4-48
4-11.	Types of VF Tones	4-50
4-12.	SASS Test Key Commands	4-51
4-13.	Dial-Up Tests and Associated Subtests	4-54
4-14.	Dial-Up Test Setup Parameters	4-55
4-15.	Smart-Pro Tests	4-61
4-16.	Smart-Pro Test Key Commands	4-62
4-17.	SASS Test Key Commands	4-64
4-18.	DATU Manual Termination Codes	4-66
4-19.	SASS Test Key Commands	4-73
5-1.	ADSL Auto-Test Setup Parameters	5-4
5-2.	WB Noise/Level Test Setup Parameters	5-19
5-3.	Longitudinal Balance Test Setup Parameters	5-24
5-4.	Send WB Tone Test Setup Parameter	5-26
5-5.	ADSL Auto-Test Setup Parameters	5-28
5-6.	WB Impulse Noise Test Setup Parameters	5-32
6-1.	TDR vs. Parametric Fault Location Tests	6-2
6-2.	TDR Auto-Test Setup Parameters	6-6
6-3.	TDR Auto-Test Softkeys	6-9
7-1.	Storage Limitations of Saved Result Files	7-2
B-1.	Replacement Parts for the CopperPro Loop Tester	B-2
B-2.	Optional Accessories for the CopperPro Loop Tester	B-4

List of Figures

Figure	Title	Page
1-1.	Standard Accessories	1-10
2-1.	Top, Front, and Side Panels	2-2
2-2.	Back Panel	2-7
3-1.	CopperPro Startup Screen	3-2
3-2.	Main Menu.....	3-3
3-3.	Typical Setup Menu	3-6
3-4.	USER OPTIONS Menu	3-10
3-5.	System Setups Screen	3-18
4-1.	POTS Auto-Test Setup Screen.....	4-2
4-2.	POTS Auto-Test Summary Results.....	4-6
4-3.	POTS Toolbox	4-8
4-4.	Voltage Test Results: Idle POTS Line	4-10
4-5.	Continuous Voltage Test Result Screen.....	4-11
4-6.	Shorts & Grounds Test Results: Short	4-13
4-7.	Opens Test Result: Good Pair.....	4-16
4-8.	Adjusted Opens Test Screen	4-17
4-9.	Opens Test Result Screen: Possible Split or Water.....	4-19
4-10.	Splits Test: Connection Diagram	4-20
4-11.	Splits Test Result Screen.....	4-21
4-12.	RFL Test Results: Fault Value and Position	4-23
4-13.	RFL Test Results: Double-sided Fault or Short	4-24
4-14.	Two-Wire RFL Test Results: Tip Ground.....	4-25
4-15.	Two-Wire RFL Test Results: Distance to Fault	4-26
4-16.	RFL Multiple Wire Gauge Entry Screen.....	4-27
4-17.	Three-Wire RFL Test Results: Good Wire Strap	4-30
4-18.	Three-Wire RFL Test Results: Distances.....	4-31
4-19.	Three-Wire RFL Test: Good Pair Strap	4-32
4-20.	RFL Multiple Wire Gauge Entry Screen.....	4-33
4-21.	Load Coils Test Results	4-35
4-22.	Load Coil Graph: 6 Loads.....	4-36
4-23.	Leakage Stress Test Results: Faulty Pair.....	4-39
4-24.	VF Noise Test Results.....	4-42
4-25.	Power Harmonics Test Results	4-43
4-26.	Connection Diagram for the VF Loss Test.....	4-45
4-27.	VF Loss Test Results	4-46
4-28.	Longitudinal Balance Test Results: Good Pair.....	4-48

4-29.	Send VF Tone Screen.....	4-49
4-30.	Dial-Up Tests Selection Screen.....	4-56
4-31.	Smart-Pro N-Tone Slope Test Results.....	4-63
4-32.	Terminator VF Auto-Test Selection Screen.....	4-68
4-33.	Terminator VF Auto-Test Summary Results.....	4-69
4-34.	Terminator VF Auto-Test Results: SmartTone Loss st.....	4-70
5-1.	ADSL Auto-Test Connection Screen.....	5-3
5-2.	ADSL Auto-Test Connection Screen.....	5-4
5-3.	DSL Auto-Test Summary Results: HDSL2.....	5-7
5-4.	DSL Auto-Test Loss Results: HDSL2 Loop Attenuation.....	5-8
5-5.	DSL Auto-Test Loss Results: ADSL SNR Graph.....	5-10
5-6.	DSL Auto-Test Loss Results: ADSL Bits / Tone Graph.....	5-11
5-7.	DSL Auto-Test Loss Results: ALL Service Types.....	5-12
5-8.	DSL Auto-Test Loss Results: Qualified Service List.....	5-13
5-9.	XDSL Toolbox.....	5-18
5-10.	WB Noise/Level Test Results: ISDN Crosstalk.....	5-20
5-11.	WB Noise/Level Test Results: Working ADSL Line.....	5-22
5-12.	WB Loss Test Result Screen.....	5-23
5-13.	WB Longitudinal Balance Test Results.....	5-26
5-14.	ADSL Auto-Test Results: Loss Graph.....	5-29
5-15.	WB Impulse Noise Test Results.....	5-33
6-1.	TDR Auto-Test Results: Open.....	6-7
6-2.	TDR Toolbox.....	6-11
6-3.	Pair 1 and 2 Compare Test Result Screen.....	6-14
6-4.	Pair 1 Monitor Test Result: Intermittent Splice.....	6-15
7-1.	Saved Results Selection Screen.....	7-4
7-2.	Saved Results Screen: Viewing Text Results.....	7-6
7-3.	Saved Results: All Text Results.....	7-7
7-4.	Saved Results: List of TDR Waveforms.....	7-9
7-5.	Saved Results: List of Frequency Sweep Graphs.....	7-10
8-1.	Download Screen: Waiting for File.....	8-3
8-2.	Final Download Screen.....	8-4
B-1.	Replacement Parts for the CopperPro Loop Tester.....	B-3
B-2.	Optional Accessories.....	B-5

Chapter 1

Introduction

Using This Guide

This *990DSL CopperPro Loop Tester Users Guide* shows you how to operate the 990DSL CopperPro Loop Tester (hereafter referred to as the “CopperPro” or “tester”). It provides instructions for configuring the CopperPro and using it to precisely locate common faults on a loop and to verify the ability of a copper loop to transport various classes of high-speed data services.

This guide is intended for users who want to start using the CopperPro immediately with minimal instruction. It describes the main features of the tester and explains how to set up, operate, and care for it. For your protection, it is important that you observe all warnings and important safety information in this guide and on the tester itself.

Introduction

The 990DSL CopperPro Loop Tester is a portable, battery-operated handheld tester that is used for cable installation testing, fault location, and digital service qualification of outside plant (OSP) paired copper cables.

As a cable installation test tool, you can use the CopperPro with an external multiple-pair access module in a PC-controlled mode to perform automated, single-ended conformance testing of a newly installed cable according to operating company guidelines. If more rigorous conformance testing is required, you can use a second CopperPro with a multiple-pair access module at the far end of the cable to perform precision-terminated transmission testing.

As a fault location test tool, you can use the CopperPro to precisely locate common physical cable faults, including shorts, grounds, crosses, opens, splits, and pair imbalances that are caused by poor splice joints. The tester can also be used to expose corroded metallic faults on unused pairs. This type of problem, which is virtually undetectable by conventional meters, can eventually cause a pair to be noisy after it is cut into service.

The CopperPro is also a useful tool for helping you find the root cause of transmission problems, such as excessive loss and noise. Additionally, it can detect and identify loop treatment and fault-sectionalizing devices that are commonly installed on lines, such as range extenders (REGs), Network Interface Devices (NIDs), and Maintenance Termination Units (MTUs).

As a digital service qualification test tool, you can use the CopperPro to verify that a cable pair is suitable for voice frequency POTS services (such as Caller ID and analog modem data) and for special services, such as DDS, ISDN, T1, E1, HDSL, HDSL2, HDSL4 and ADSL. The CopperPro uses wideband loss, Gaussian noise, impulse noise, and crosstalk measurements, as well as load coil detection and location capability to qualify copper pairs for these high-speed services.

Design Highlights and Features of the CopperPro

The CopperPro's design and performance features are highlighted below.

Physical Features

- Rugged, wide-temperature design that is specifically made for the harsh OSP environment
- Lightweight and compact in size (4 lbs.)
- Replaceable internal option board for functional scalability
- High contrast, sunlight-readable graphics display with a backlight
- Large, tactile keys that provide an audible response when pressed
- High capacity, rechargeable battery pack that provides a full eight hours of operation
- Modular field-replaceable test leads (two pairs plus Ground)

User Interface Features

- One-button “test suite” menu for automated high-level testing
- Comprehensive “toolbox” menu for individual, in-depth testing
- Context-sensitive softkeys that provide easy navigation
- Graphic pictorial test setup and results display for easy interpretation
- Graphical loss, noise, and SNR displays with a scrolling cursor

- Continuous test result mode with large numerals and a relative-change scale for marking and recording peak signal excursions
- Remote control operation and program download capability through a serial port
- Test result storage and printout
- User-settable fault limits with industry-standard defaults.
- Test result upload in either column or tab-delimited format (for direct import to spreadsheet program)

Testing Features

Note

An asterisk indicates that the item requires the Wideband Option module.

- Integrated far-end-device control for automated, terminated testing
- Double-ended “same-pair testing” capability (requires no control pair)
- AC/DC Voltage, Shorts & Grounds, Opens, Leakage, and Resistance Fault Location (RFL) physical tests
- Load Coil, Noise, Loss, SNR*, and Longitudinal Balance transmission tests
- Impulse Noise test with E, F, and G filters*
- Voiceband (0 – 20 kHz) and Wideband* (10 kHz – 1.2 MHz) transmission tests
- PSD mask overlays that depict crosstalk patterns for common types of interference*
- Single ended ADSL DSLAM/modem verification, with data rate prediction*

- Automated dial-up testing that is compatible with a variety of central office (C.O.) tone equipment
- Full TDR capability with Auto-Test waveform interpretation software*
- Tracing Tone, Monitor, and a fully integrated Dial Set operation
- Caller ID and automatic number ID (ANI) tests
- Non-intrusive “footprint analysis” of service types on working pairs

Safety Information

The CopperPro is intended for use by qualified personnel only. The tester is designed for use with circuits that have a maximum of 350 VDC or peak AC, line-to-line or line-to-ground.

The following general safety precautions must be observed during all phases of operation, service, or repair of the CopperPro. Failure to comply with these precautions or with specific warnings in this guide violates the safety standards of design, manufacture, and intended use of the tester. Fluke Networks assumes no liability for the customer’s failure to comply with these requirements.

⚠ Warnings









- **If this product is used in a manner not specified by the manufacturer, the protections provided by the product may be impaired.**
- **Never connect the CopperPro to a circuit when lightning storms are nearby.**
- **Do not open the case. There are no user-serviceable parts inside.**

⚠Warnings

- **Should the LCD become damaged, the liquid crystal material can leak. Avoid all contact with this material, especially swallowing. Use soap and water to thoroughly wash all skin and clothing contaminated with the liquid crystal material.**
- **When using an AC power source, use only the supplied AC Adapter/Charger to power or charge the CopperPro.**
- **Do not use the CopperPro if it operates abnormally. Protection may be impaired.**
- **Inspect the CopperPro before using. Do not use it if it is damaged.**
- **When servicing the CopperPro, use specified replacement parts only.**
- **This product is not intended to be used to measure mains voltages (CAT I, II, III or IV) and should only be connected to powered circuits where over-voltage protections have been incorporated.**

Table 1-1 describes the international electrical symbols that are found on the CopperPro and used in this guide.

Table 1-1. International Electrical Symbols

Symbol	Meaning
	Warning: Risk of electric shock.
	Important Information. See specific explanations where this symbol is displayed in this guide.
	Equipment is protected by double insulation or reinforced insulation to protect the user against electric shock.
	Battery should be recycled.
	Do not mix with solid waste stream. Dispose using a qualified recycler or hazardous material handler.
	Conforms to the requirements of the European Union and European Free Trade Association (EFTA).
	Canadian Standards Association. Conforms to relevant safety standards in Canada and the United States.
	This instrument contains a Nickel Metal Hydride battery pack. Fluke Networks subscribes to the U. S. Rechargeable Battery Recycle Corporation (RCRB) program. Contact your authorized Fluke Networks Service Center for recycling information.

Care and Maintenance

The CopperPro is designed to be maintenance free. Treat it with care to ensure the best performance. The suggestions below will help you to fulfill the obligations of the warranty and enjoy the tester for many years.

- Avoid rough handling

Although the CopperPro is designed for use in the rugged OSP environment and can absorb a generous amount of shock and vibration, avoid dropping the tester. If you must ship the tester, use the original packaging.

- Clean carefully

The plastic casing for your CopperPro has a finish that should retain its durability for many years. To clean the tester, use a soft, slightly damp cloth. To remove any stains, use a mild soap. Never use detergents, solvents, or abrasive cleaners on the tester.

Service and Adjustment

Service and adjustment of the CopperPro should be performed by trained Fluke Networks service personnel only.

If you experience a problem with the CopperPro, visit the Fluke Networks Web site at www.flukenetworks.com. Click **Support** to display the **Support Solutions** page. You can also send email to support@flukenetworks.com or call one of the following numbers to report a problem:

- USA: 1-888-99-FLUKE (1-888-993-5853)
- Canada: 1-800-363-5853
- Europe: 00800 632 00 or +44 1923 281 300
- Beijing: 86 (10) 6512-3435
- Japan: +81-3-3434-0181
- Singapore: +65-6738-5655
- Anywhere in the world: +1-425-446-4519

Visit our website for the latest list of phone numbers.

If the CopperPro requires repair, service center personnel will provide you with shipping information and repair prices. If the CopperPro is covered under warranty, it will be promptly repaired or replaced (at Fluke Network's option) and returned to you, postage paid, at no charge. See the registration card for warranty terms. If the warranty has lapsed, Fluke Networks will repair the CopperPro for a fixed fee and return it, postage paid, to you.

Checking the Shipping Container

Remove the items from the shipping container and check that the package contains all of the standard accessories in the following list. Match each item with those shown in Figure 1-1. If any item is missing or damaged, contact your place of purchase.

- 990DSL CopperPro Loop Tester
- NiMH Rechargeable Battery Pack (installed; PN 665083)
- Test Lead Bag (PN 2003588)
- Power Supply INTL (PN 944223)
- Shoulder Strap (PN 1576950)
- RS-232 Cable (PN 944806)
- 12V Vehicle Battery Charger/Adapter (PN BE720)
- Line Cord (as appropriate for the country of usage)
- RFL Strapping Cord (PN 1320505)
- Wire Gauge (not shown; PN 1312371)
- This User's Guide (not shown; PN 1554870)
- Warranty Registration Card (not shown; PN 929158)

For a list of replacement parts and optional accessories that you can order for your CopperPro, see Appendix B.

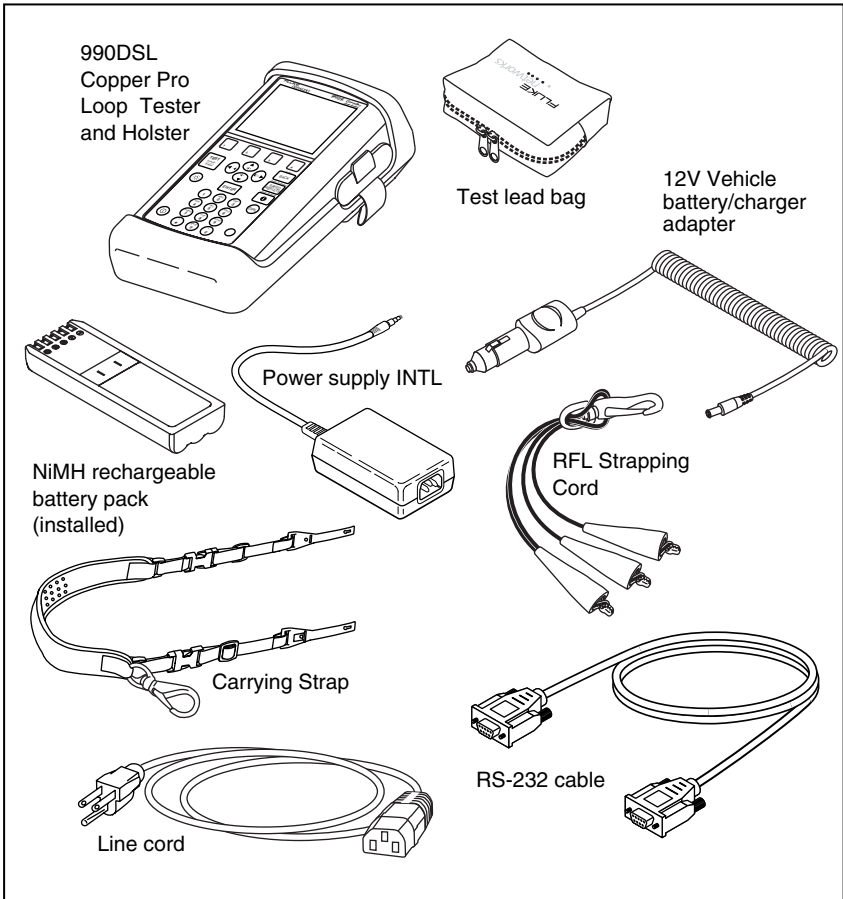

Figure 1-1. Standard Accessories

Technical Support

Fluke Networks offers a variety of support options to help you get the most from your CopperPro. If you require technical support, please have the following information available:

- Your name and company
- Model number and serial number of the CopperPro
- A description of the problem and any error messages that appear on the LCD.

For application or operation assistance or information about the tester, you can send email to support@flukenetworks.com or call one of these numbers:

For operating assistance in the USA, call 1-800-28-FLUKE (1-800-283-5853). This number is only for TECH SUPPORT in the US.

To order accessories or to find out the location of the nearest Fluke Networks distributor or service center, call:

- USA: 1-888-99-FLUKE (1-888-993-5853)
- Canada: 1-800-363-5853
- Europe: 00800 632 00 or +44 1923 281 300
- Beijing: 86 (10) 6512-3435
- Japan: +81-3-3434-0181
- Singapore: +65-6738-5655
- Anywhere in the world: +1-425-446-4519

Visit our website for the latest list of phone numbers.

You can also visit the Fluke Networks Web site at www.flukenetworks.com. Click **Support** to display the **Support Solutions** page.

Chapter 2

Controls and Connections

Introduction

This chapter describes the physical layout of the CopperPro. The chapter begins with an overview of the tester's front, side, and back panels so that you know where the various controls and connectors are located and so that you can familiarize yourself with the functions of the keys and indicators. You will then learn how to connect the CopperPro to an external power supply and a printer and how to charge the tester's internal battery pack.

The CopperPro Loop Tester: at a Glance

This section acquaints you with the physical layout of the CopperPro.

Front Panel

Figure 2-1 identifies the elements on the tester's front, top, and side panels. Following the figure are descriptions of the numbered items in the illustration.

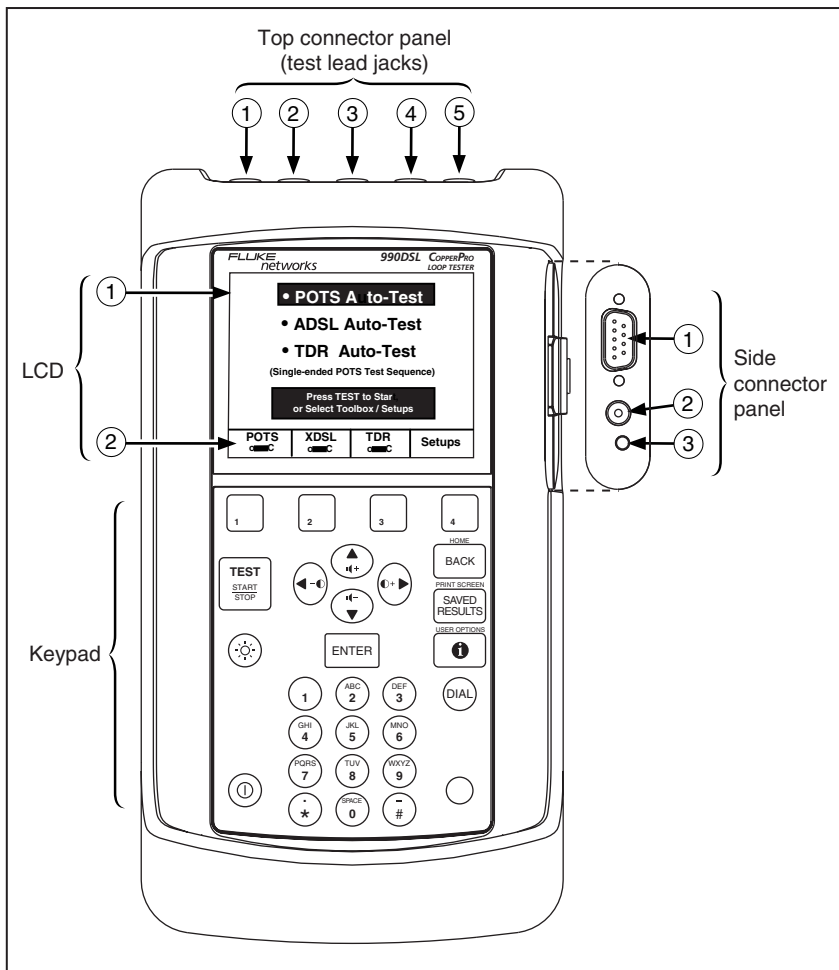

Figure 2-1. Top, Front, and Side Panels

acy02f.eps

LCD

The LCD is a shock-mounted, sunlight-readable, ¼-VGA (320 x 240 pixel) graphic Liquid Crystal Display. A low-power Electro-luminescent (EL) module provides backlighting to the LCD.

The LCD has two areas:

- Display area (item ①)
 This area displays the prompts, test and setup menus, test results, and messages.
- Four softkey labels (item ②)
 These labels identify the screen-dependent function keys. To activate a function, press its softkey (1, 2, 3, or 4), which is located on the tester's keypad directly below the label.

Keypad

The keypad is a sealed, waterproof membrane that has 29 keys. Table 2-1 describes the function of each key.

Table 2-1. Functions of the CopperPro Keys



Key	Function
	<p>Four rectangular numbered keys that are located directly under the LCD.</p> <p>These are software-defined keys (called “softkeys”) that carry out commands related to the currently displayed screen. To locate the function of a key, look on the LCD directly above the key.</p>
	<p>Starts the selected test and stops the currently running test.</p>

Table 2.1. Functions of the CopperPro Keys (continued)























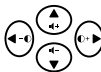

Key	Function
	Turns the LCD's backlight on or off.
	Turns the CopperPro on or off.
	<p>Shift key (yellow).</p> <p>Some keys have two functions (for example, the BACK key). When you press and release the Yellow Shift key, then press a key that has two functions, the alternate function of the key is activated. The alternate function is printed in yellow letters above the key.</p>
	Causes the CopperPro to go “off-hook” on the T & R test leads and function as a telephone dial set. Hangs up when this key is pressed again.
<p>USER OPTIONS</p> 	Press  then  to display the USER OPTIONS menu.
<p>PRINT SCREEN</p> 	<p>Has two functions:</p> <ul style="list-style-type: none"> • Press  to access stored results files. • Press  then  to print the contents of the currently displayed screen.

Table 2-1. Functions of the CopperPro Keys (continued)

Key	Function
 <p>HOME BACK</p>	<p>Has two functions:</p> <ul style="list-style-type: none"> • Press  to return to the previously displayed screen. • Press  then  to display the Main menu (see Figure 3-2).
	<p>Four directional arrow keys have the following functions:</p> <ul style="list-style-type: none"> • To select a test or edit a parameter, press an arrow key to move the cursor in the direction in which the arrow points (up, down, left, or right). • Press . Then press  to decrease or  to increase the contrast of the LCD. • Press . Then press  to increase or  decrease the volume of the speaker.
 <p>ENTER</p>	<p>Does the following:</p> <ul style="list-style-type: none"> • Selects test options. • Exits Edit mode
<p>Alphanumeric Keys</p>	<p>Provide a 12-key telephone pad so that you can enter numbers, the asterisk (*), and pound sign (#).</p> <p>Press , then press the associated number key to select an alphabetic character, the decimal, space, or dash. Press  again to exit alphabetic entry mode and return to number entry mode.</p> <p style="text-align: center;"><i>Note</i></p> <p style="text-align: center;"><i>To display an alphabetic character, press , then continue to press the associated number key until the desired alphabetic character appears.</i></p>

Top Connector Panel

The top connector panel has five 2 mm test lead connectors. These connectors are color-coded for easy identification. The test lead connectors are identified in Figure 2-1 as follows:

- ① Tip test lead (black)
- ② Ring test lead (red)
- ③ Ground test lead (green)
- ④ Tip 1 test lead (yellow)
- ⑤ Ring 1 test lead (blue)

Side Connector Panel

The side connector panel is protected from rain by a tethered plug that is attached to the holster. This panel has the following components, which are identified in Figure 2-1:

- RS-232 port (item ①)
A nine-pin male D-Sub connector with locking nuts. The RS-232 port and the supplied RS-232 cable are needed when you download programs from a PC to the tester and when you control the tester remotely from a PC. With a printer cable connected, the RS-232 port enables you to print serial data.
- DC power jack (item ②)
A barrel jack that is used to power the tester externally and charge the battery. This jack accepts a 12-15 VDC center-positive voltage that is provided either by the supplied AC power supply or by the optional Vehicle Power Cord.

- Charging status LED (③)

A bicolor (red and green) LED that indicates the charging status of the internal battery pack (see “Charging the Battery” for details).

Back Panel

The tester’s back panel is shown in Figure 2-2. This panel contains a speaker (item ①) and a microphone (item ②). The speaker and microphone enable you to use the CopperPro as a dial set (see “Operating the Tester as a Dial Set” in Chapter 3 for instructions).

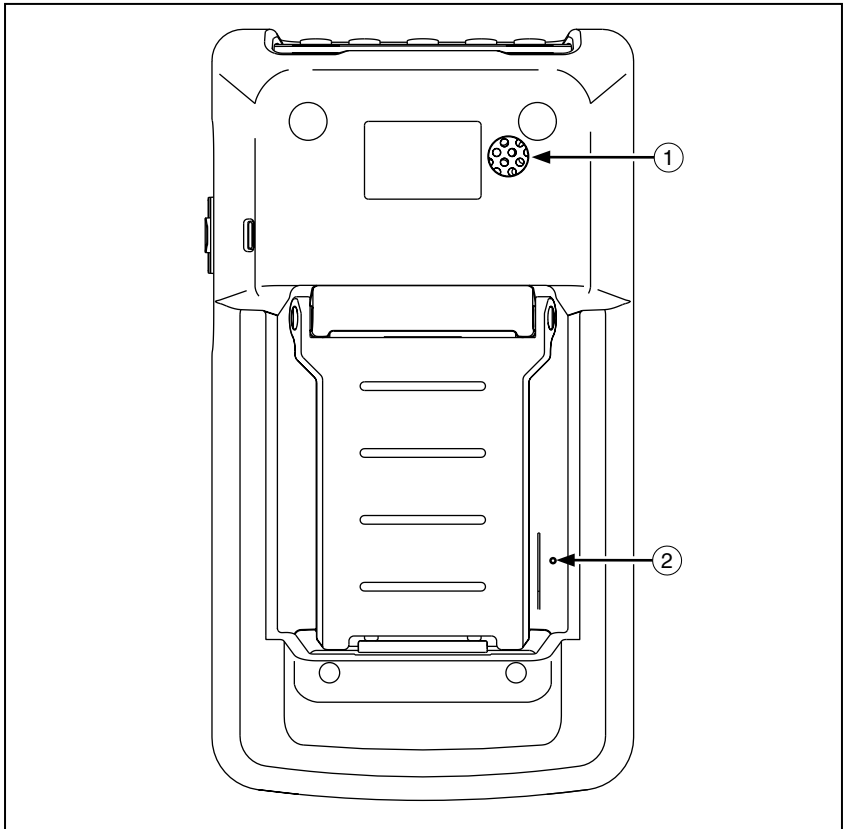

Figure 2-2. Back Panel

acy04f.eps

Connecting the CopperPro

This section shows you how to connect the CopperPro to AC power, an automobile battery, a printer, and a PC.

Connecting to AC Power

When the tester is connected to AC power, you can use the power supply as a continuous power source. In this way, you can test for long periods of time without depleting the tester's batteries.

To connect the CopperPro to AC power, follow these steps:

1. Plug the AC power cord into an AC outlet.
2. Connect the power cord DC Barrel plug into the DC connector. This connector is located on the tester's side panel (see Figure 2-1).
3. Do one of the following:
 - Turn off the tester to begin charging (see "Charging the Battery" for details).
 - Turn on the tester and begin using.

Connecting to an Automobile Battery

To connect the CopperPro to a 12 VDC automobile battery, follow these steps:

1. Plug the male cigarette lighter plug on the Vehicle Power Cord into the vehicle lighter socket.

2. Connect the DC barrel plug on the Vehicle Power Cord into the DC connector. This connector is located on the tester's side panel (see Figure 2-1).
3. Do one of the following:
 - Turn off the tester to begin charging.
 - Turn on the tester to begin using.

Connecting to a Printer

To connect the CopperPro to a serial graphics printer, do the following:

1. Attach the nine-pin female connector on the optional printer cable to the CopperPro D-Sub connector.
2. Attach the nine-pin male cable connector to the printer.

Connecting to a PC

If the CopperPro is connected to a PC, you can download and upload files and control the tester remotely from the PC. To connect the CopperPro to a PC, do the following:



1. Attach one end of the supplied RS-232 cable to the RS-232 port, which is located on the tester's side panel (Figure 2-1).
2. Attach the other end of the supplied RS-232 cable to an available port on the PC.

The Battery

The CopperPro operates on a replaceable NiMH battery pack. The battery typically provides between 16 to 24 hours of operating time. This section shows you how to check and recharge the battery.

Checking the Remaining Battery Capacity

To find out what the remaining capacity of the internal battery pack is, do the following:

1. Press  then  to display the **USER OPTIONS** menu.
2. Select **Battery Status**, then press .

The **Battery Status** screen is displayed. This screen gives you the following information about the internal battery pack:

- Battery voltage (VDC)
- Battery capacity (%)
- Estimated remaining run-time (in hours, based on normal usage)
- Battery temperature (°C)

Note

After you turn on the tester, the startup screen displays this same status information about the battery.

In the upper right corner of the screen, the tester displays two icons, which indicate the following:

- External power source in use (either AC power or not AC power)
- Battery capacity.

Responding to Low Battery Warnings

When the NiMH battery pack has about 30 minutes of operating time remaining, the tester issues a tone and displays a low-battery warning on the LCD. This warning overlays the currently displayed screen.

Note

To remove the warning, press .

If the low battery warning appears while you are operating the tester, it is advisable to connect the CopperPro to an external power source within the next several minutes to guarantee that the currently displayed test data is not lost due to a power failure. If you continue to operate the CopperPro without an external power source, the tester issues a final distinctive audible tone and powers itself off.

Charging the Battery

To charge the battery, either connect the CopperPro to AC power (see “Connecting to AC Power”) or connect it to an automobile battery (see “Connecting to an Automobile Battery”).







During operation from either external power source, the battery receives a “trickle” charge that allows you to operate the tester for extended periods of time without discharging the internal battery pack. When the CopperPro is connected to an external power source but turned off, the battery automatically undergoes a fast-charging cycle.

A full charging cycle can take between two to three hours to complete. The charging status LED on the side connector panel indicates the state of the battery charge as one of the following:

- Flashing red: indicates that the battery is being prepared for fast charging, and is in the “pre-charge” mode. This state lasts for several minutes before the battery enters fast charging mode. This state will be extended for extremely low voltage, low temperature, or high temperature battery conditions, with the fast charge mode beginning when the battery has reached the proper voltage and temperature range.
- Steady red: indicates that the battery is in fast-charging mode. In this mode, it can take up to three hours for a completely discharged battery pack to charge.
- Steady green: indicates that the battery is in the final stages of charging. The first stage, which typically lasts for about 30 minutes, occurs after the fast-charging mode is the “top off” state. The final stage is the “trickle charge” state. In this state, the battery is fully charged. The CopperPro can be left in the trickle charge state for an indefinite period of time, without harm.

Discharging Battery

To properly discharge the battery, you can leave the tester on until the battery drains or you can use the discharge facility. To use the discharge facility, complete the following:

1. Press  then  to display the **USER OPTIONS** menu.
2. Select **Battery Status**, then press .
3. Press .
4. Follow the on-screen instructions to disconnect the tester from the external power source. Then, press  (**Okay**).
5. Press .

The tester begins to discharge the battery.

Chapter 3

Setting Up and Operating the CopperPro

Introduction

This chapter shows you how to set up the CopperPro so that it suits your particular testing needs and operating preferences. The chapter begins with an introduction to the menu system and shows you how to locate desired tests, operational functions, and setup parameters. The chapter concludes by showing you how to perform basic tasks, such as adjusting the speaker volume, changing the contrast and brightness of the LCD, and using the CopperPro to dial a telephone number.

Turning the CopperPro On and Off

To turn on the CopperPro, do the following:

1. Press **Ⓞ**. This is the green On/Off key, which is located in the bottom left corner of the keypad (see Figure 2-1).

The CopperPro startup screen (Figure 3-1) is displayed:

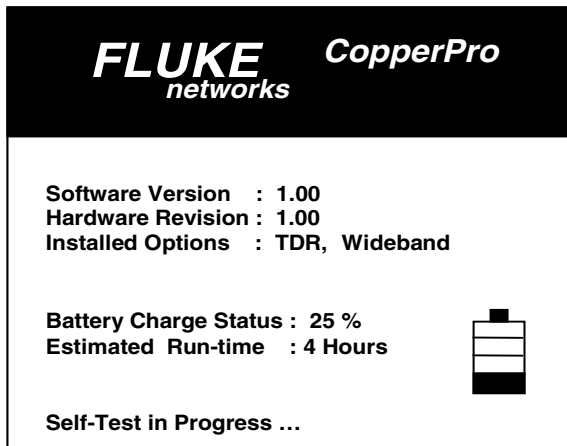

acy03s.eps

Figure 3-1. CopperPro Startup Screen

The startup screen displays general information about the tester: the software version and hardware revision, installed options (if any), and battery status and estimated remaining run-time.

2. To turn the tester off, press **Ⓞ** again.

Note



Should the tester fail to respond to the "OFF" key function for any reason, force the unit to power down by holding the key down for 5 to 6 seconds.

The Menus

The CopperPro’s test selections, setup configurations, and results are accessed through a menu system. This section shows you how to display the **Main** menu. You will then learn how to display the test and setup menus.

Displaying the Main Menu

The **Main** menu is the top-level menu. From this menu, you can access all of the CopperPro’s setup and testing functions.

After you turn on the CopperPro, it conducts a series of self-tests, then displays the **Main** menu (Figure 3-2). If the CopperPro is already turned on, you can return to the **Main** menu from anywhere in the menu hierarchy by pressing , then pressing .

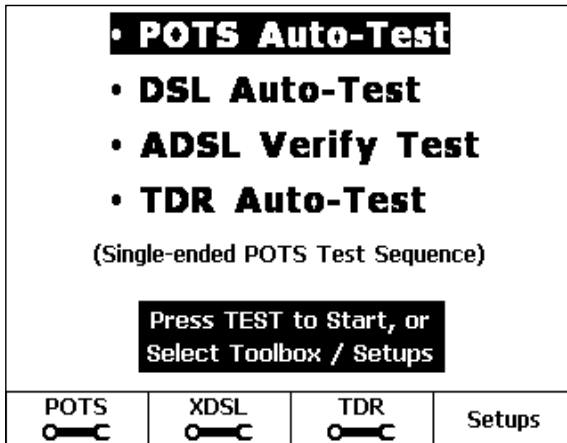

Figure 3-2. Main Menu

acy05s.eps

From the **Main** menu, you can access the following:

- Auto-Tests

The menu lists the three automatic tests or Auto-Tests: POTS, DSL, and TDR, plus the ADSL Verify Test. Each Auto-Test is comprised of a series of individual diagnostic tests that run automatically and in sequence with the press of a single key. The POTS, DSL, and TDR Auto-Tests are described in detail in Chapters 4, 5, and 6, respectively. The ADSL Verify Test is described in Chapter 5.

- “Toolbox” tests

Each “toolbox” contains a group of functionally related individual tests. The **POTS**, **XDSL**, and **TDR** softkeys, which are located at the bottom of the **Main** menu, each let you access a group of tests. For descriptions of the tests in the POTS, XDSL, or TDR toolbox, see Chapter 4, 5, or 6, respectively.

- Test setup menus

The **Setups** softkey provides direct access to the setup menu for a selected (highlighted) test. For information on setting up a test, see the setup section for that test in Chapter 4, 5, or 6.

Displaying the Previous Menu or Screen

To display the previously displayed menu or screen, press .

Displaying a Setup Menu

This section shows you how to display the setup menus for an Auto-Test and a test in a toolbox. For descriptions of the setup parameters found on these menus, see “Generic and Test-Specific Setup Parameters”.

Auto-Test Setup Menu

To display the setup menu for an Auto-Test, do the following:

1. From the **Main** menu (Figure 3-1), press \odot to select the desired Auto-Test.
2. Press $\boxed{4}$ (**Setups**).

The **Setups** menu for the Auto-Test you selected is displayed.

Toolbox Test Setup Menu

To display the setup menu for a test in a toolbox, do the following:

1. From the **Main** menu, press $\boxed{1}$ (**POTS**), $\boxed{2}$ (**XDSL**), or $\boxed{3}$ (**TDR**).
A menu of tests in the selected toolbox is displayed.
2. Select the test that you want to set up. Then, press $\boxed{4}$ (**Setups**).

The **Setups** menu for the test is displayed.

Generic and Test-Specific Setup Parameters

Figure 3-3 shows a typical setup menu for a toolbox test (VF Noise). Every setup menu has two groups of parameters. At the top of the screen is the first group, which consists of three generic parameters (described in Table 3-1). The parameters are considered “generic” because they apply to *all* of the CopperPro’s tests.

You can change the value of a generic parameter from any setup screen (see “Editing the Setup for a Test”). Just be aware that when you save the change, it is stored in the tester’s memory and applies to *every* CopperPro test.

Setups - VF Noise			
Facility Cable No. - NPG5804			
Pair / Terminal No. - 1001			
CopperPro Pair No. - 1			
Term. Impedance - 600 Ohms			
Measurement Filter - C-Message			
Nm Pass Thresh. - ≤ 20 dBrn			
PI Pass Thresh. - ≤ 80 dBrn			
Edit			Restore Defaults

Figure 3-3. Typical Setup Menu

acy07s.eps





Beneath the generic setup parameters is a second group of setup parameters. The parameters in this group are specific to the selected test. Look at the **Setup-VF Noise** screen, which is shown in Figure 3-3. The four parameters on the bottom of the screen apply to the VF Noise test only. For descriptions of the setup parameters for a particular test, refer to the table in the setup section for that test.

Table 3-1. Generic Setup Parameters



Parameter	Description
Facility Cable No.	This number identifies the cable name of the pair on which the test is being conducted. In the highlighted field, supply the alphanumeric cable name (16 characters maximum).
Pair/Terminal No.	This number identifies the specific single cable pair, the cross-box binding post, or the inside terminal number on which the test is being conducted. In the highlighted field, supply the number (five digits maximum).
CopperPro Pair No.	This number identifies the CopperPro test lead pair. In the highlighted field, type a 1 (for T & R) or a 2 (for T1 & R1 , if no external multiple-pair access modules are attached).

Editing the Setup for a Test

To edit the setup for a test, complete the following:

1. To change the value of a generic parameter, refer to the information in Table 3-1 and complete the following for each parameter you want to change:
 - a) Press  or  to select the parameter. Then, press  (**Edit**).
The tester is now in Edit mode.
 - b) In the highlighted field, use the keypad to type the desired value. When you finish, press .

The values are saved in the tester's memory and apply to all CopperPro tests until you change them.

2. To change the value of a test-specific parameter, complete the following:
- Press  or  to select the value you want to change. Press  (**Edit**).
The tester is now in Edit mode.

Note

Consult Table 3-2, which provides some helpful tips for operating the tester in Edit mode.





- Do the following:
 - If the parameter you want to change has a fixed group of choices, press  or  until the desired choice appears in the field. Then, press  to save the selection.
OR
 - If the parameter has an alphanumeric field, a blinking cursor appears on the first (left-most) character in the field. To change the parameter's value, use the keypad to type the new value. As you type each character, it appears in the field and the cursor advances to the next position, allowing you type the next character. When you finish, press  to save the change.

Table 3-2. Operating the Tester in Edit Mode

If you want to	Do this
Put the tester in Edit mode	Press [1] (Edit).
Enter numbers, asterisk (*) or pound sign (#)	Type the values directly from the keypad by pressing the number keys, asterisk (*), or pound sign (#).
Enter alphabetic characters	Press [O] to put the tester in alphabetic text entry mode. Then, press the key with the desired alphabetic character. Keep pressing the key until the desired alphabetic character is displayed.
Exit alphabetic text entry mode and return to numeric entry mode	Press [O] .
Move the cursor forward one position without changing the displayed character	Press [→] .
Move the cursor backward one position without changing the displayed character	Press [←] .
Move the cursor back one position and overwrite the previous character	Press [BACK] .
Exit Edit mode and save the changes	Press [ENTER] .
Exit Edit mode, without saving the changes	Press [1] (Edit).
Restore factory default setup values	Press [4] (Restore Defaults).

Configuring the Tester

This section shows you how to configure the CopperPro so that it functions appropriately for your particular work environment and testing situations. The **USER OPTIONS** menu (Figure 3-4) lists the options available for configuring the tester and customizing it to your needs.

Zero Leads	Phone Numbers	Power-Save Timers	Language & Units
Battery Status	Program Download	RS232 Port Setup	Date / Time
System Version	Company Info.	Saved Results	Self-Test
(Test Lead calibration)			
Select function, then press Enter; or press System Setups.			
Initialize Bluetooth	Upload Setups	Restore All Defaults	System Setups

Figure 3-4. USER OPTIONS Menu

acy08s.eps

Function Keys

- **Initialize Bluetooth** initializes the optional Bluetooth Communications modules connected to the tester and a PC, for wireless remote control or upload operation.
- **Upload Setups** uploads stored setups to a PC via the serial port.
- **Restore All Defaults** resets all setup options to factory defaults.
- **System Setups** allows entry of operator name, wire center, location, and job number (refer to “Creating a Custom Header for Test Result Files” later in this chapter).

Setting the Date and Time

To set the date and time, follow these steps:

1. Press **○**, then **ⓘ** to display the **USER OPTIONS** menu (Figure 3-4).

2. Select **Date/Time**. Press **ENTER**.

The **Date/Time** menu is displayed.

3. Press **↓** to move the cursor down to the **Time Display Mode** field. Press **⏎** (**Edit**). Then, press **↔** to select one of the following formats for displaying the time:

- 12-hour (default)
- 24-hour

Press **ENTER** to save your selection.









4. Press **↓** to move the cursor down to the **Date Display Mode** field. Press **⏎** (**Edit**). Then, press **↔** to select one of the following formats for the date:

- MM/DD/YYYY
- DD.MM.YYYY

Press **ENTER** to save your selection.

5. Press **↑** to move the cursor up to the **Current Time** field and set the time. To do this, complete the following:

- a) Press **⏎** (**Edit**). In the Hour field, type the hour. Then press **ENTER** to save the value.
- b) Press **→** to move the cursor to the Minutes field. Press **⏎** (**Edit**). Type the minutes, then press **ENTER** to save the value.
- c) If you selected **12-hour** as the time format, press **↔** to move the cursor to the Time of Day field. Press **⏎** (**Edit**). Press **↓** to select **AM** or **PM**, then press **ENTER** to save the selection.

6. Press  to move the cursor to the **Current Date** field and set the date. To do this, complete the following:
 - d) Press  (**Edit**). In the first field, type the number for the current month (or day, if you selected DD.MM.YYYY as the display mode). Press  to save.
 - e) Press  to move the cursor to the next field. Press  (**Edit**). Type the number for the current day (or month), then press  to save.
 - f) Press  to move the cursor to the Year field. Press  (**Edit**). Type the year, then press  to save.

Your tester is now programmed with the current time and date.

Setting a Timer to Conserve Power

To conserve battery power, you can program a timer that automatically switches the tester into low-power mode or power-down mode after a specified period of inactivity.

The CopperPro has two timers:

- “Snooze” Timer

Causes the CopperPro to go into low-power mode if no keypad activity is detected for the user-specified time period. When the time elapses, the tester emits a distinctive tone and the display goes blank.

Press any key to reactivate the tester and reset the timer.

- “Power Down” Timer

Causes the CopperPro to automatically turn off if no keypad activity is detected for the user-specified time period. The tester emits distinctive tone when the time elapses and turns itself off.

Press  to turn the tester back on.

To set a timer, follow these steps:

1. Press **O**, then **I** to display the **USER OPTIONS** menu (Figure 3-4).
2. Select **Power-Save Timers**. Press **ENTER**.
3. To change a timer's setting, position the cursor on the timer. Then, press **I** (**Edit**).
4. Supply the desired period of inactivity. Then, press **ENTER** to save the value.

Note

The default period of inactivity is 10 minutes for the Snooze timer and 20 minutes for the "Power Down" timer.

Selecting a Language and Associated Units of Measure

The CopperPro displays and prints information in the following languages:

- English (U.S., U.K., and Canada)
- Spanish
- French (France and Canada)
- Portuguese (Brazil)
- German
- Danish

The tester also displays length in different units of measure.

When you select a language for the tester's displays, the units of measure associated with that language (and country) are automatically chosen. These include units of measure for temperature, distance, and VF Noise, as well as conductor names and the typical wire gauges that are employed for the language/country you selected.

The default language for the tester's displays is **English (USA)**.

To change the language and associated units of measure, complete the following:

1. Press \bigcirc then $\boxed{\text{I}}$ to display the **USER OPTIONS** menu (Figure 3-4).
2. Select **Language & Units**. Press $\boxed{\text{ENTER}}$.
The cursor is positioned on the **Language** field.
3. Press $\boxed{1}$ (**Edit**). Then, press \leftarrow to display the desired language/country.
Press $\boxed{\text{ENTER}}$ to save your selection.

The language you selected now appears in the **Language** field. The units of measure associated with that language are also displayed.

Creating a Phone List

You can create and store a list of telephone numbers that you use frequently. The list can save you time when you run the dial-up tests described in Chapter 4. The tester can store up to 20 telephone numbers. If a number changes or is no longer needed, you can edit it or delete it from the list. This procedure shows you how to create (add), delete, and edit phone numbers.

To create a phone list:

1. Press \bigcirc then $\boxed{\text{I}}$ to display the **USER OPTIONS** menu (Figure 3-4).
2. Select **Phone Numbers**. Press $\boxed{\text{ENTER}}$.
3. Press **Add Number**.
4. Use the tester's keypad to type the number, then press $\boxed{\text{ENTER}}$.



The number is added to the phone list.

To delete a phone number:

1. Select the number that you want to delete.
2. Press **Delete Line**.

The selected number (and associated information in the “Remarks” column) is removed from the phone list.

To edit a phone number or notes in the **Remarks** field:

1. Press the ⬅ or ➡ key to select the **Number** or **Remarks** field. Then, press  (**Edit**).
2. Press the ⬅ or ➡ key to move the cursor to the desired position within the selected field. Do the following:
 - To type numbers, the asterisk (*), and pound (#) characters, press the desired key.
 - To type alphabetic characters (uppercase only), press ○, then press the desired key.
 - To put in a space, press ○, then press 0.
 - To toggle between alphabetic and numeric entry modes, press ○.
3. Press  when done.

Storing the Serial Number and Property Information

If desired, you can store the serial number and owner information for your CopperPro in the tester's memory.

To store property information for the tester, follow these steps:

1. Press \bigcirc then [i] to display the **USER OPTIONS** menu (Figure 3-4).
2. Select **Company Info**. Press [ENTER] .
The **Company Info** screen is displayed. The cursor is positioned on the **Name** field.
3. To supply information on this screen, complete the following:

Note

Zipcode and **Phone No.** can consist of up to 16 alphanumeric characters. All other parameters can consist of up to 30 alphanumeric characters.

- a) Position the cursor on the desired field. Then, press [Edit] .
- b) Use the keypad to enter alphabetic or numeric information.

To enter alphabetic information, press \bigcirc to put the tester in Shift mode. Then, press the desired alphabetic key until the character you want is displayed. Press [Right Arrow] to advance the cursor to the next position and type the next character. Continue in this manner until the desired information is displayed.



To enter numeric information, press the desired number key. Press [Right Arrow] to advance the cursor to the next position and type the next number. Continue in this manner until all of the information you want is displayed.

- c) Press [ENTER] to save.

Configuring the Serial Port



If you want to print, download and upload files, or operate the CopperPro remotely, you need to enable communications between the tester and an external PC or printer.

To configure the tester's serial port for communications with a PC application or serial printer, complete the following:

1. Press  then  to display the **USER OPTIONS** menu (Figure 3-4).
2. Select **RS232 Port Setup**. Press .
3. The **RS-232 Port Setup** screen is displayed. The cursor is positioned on the **Baud Rate** parameter.

Note



The baud rate is pre-configured at 38.4 kb/s for PC uploading and downloading operations. Printer baud rates are internally preset for the Seiko DPU-414 and DPU-411 printer choices.

4. To change the information on this screen, complete the following for each parameter:
 - a) Position the cursor on the parameter, then press  (**Edit**).
 - b) Press  until you display the desired choice.
 - c) Press  to save your selection.

Creating a Custom Header for Test Result Files

You can create a custom header for your test result files. The purpose of the header is to identify the operator, company name, test site, and job number. When you view or print a test report, the information that you supply in the following procedure can be selected to appear in the header of the file. This information applies to all of your saved result files until you change it.

To create a header, follow these steps:

1. Press  then  to display the **USER OPTIONS** menu (Figure 3-4).

2. Press (**System Setups**). Press .

The **System Setups** screen (Figure 3-5) is displayed. This screen has four parameters. The cursor is positioned on **Operator Name**.

Note

The information you supply for each parameter on this screen can be up to 30 alphanumeric characters long.

System Setups			
Operator Name - <input type="text"/>			
Wire Center - <u>FLEETWOOD CO</u>			
Location - <u>2144 Adams St.</u>			
Job Number - <u>1021-4443</u>			
To include Operator Name, Location, & Job Number in Saved Test Results Header, press "Include All" below :			
Edit		Include All	List Wire Centers

Figure 3-5. System Setups Screen

acy09s.eps

3. To supply an operator name, press (**Edit**). In the **Operator Name** field, type the name. When you finish, press .

Note

Consult Table 3-2 for assistance with operating the tester in the Edit mode.

4. Press to move the cursor to **Wire Center**. Press (**Edit**) and supply the desired information. When you finish, press .

Note

Wire Center defines the primary work location, such as a Central Office Exchange, Cross-Connect Box, or Inside Terminal name. The tester automatically includes the information that you supply for **Wire Center** in the header.

5. Press to move the cursor to **Location**. Press (**Edit**) and supply the desired information. When you finish, press .
6. Press to move the cursor to **Job Number**. Press (**Edit**) and supply the desired information. When you finish, press .
7. To include the information you supplied for the **Operator Name**, **Location**, and **Job Number** in the header for your result files, press (**Include All**).

Note

*If you do not press (**Include All**), the tester includes only the information you supplied for **Wire Center** and a timestamp.*

Performing Basic Operations





This section shows you how to perform basic CopperPro operations so that you can quickly get started using the tester. Read this section before you run any tests.

Calibrating the CopperPro

To ensure maximum accuracy of test results, you should calibrate the CopperPro at the start of the day, whenever a significant temperature change occurs, or before you make extremely critical measurements.

The Zero Leads utility is a test lead calibration function that allows the CopperPro to compensate for test lead resistance and capacitance in subsequent Resistance Fault, RFL, and Opens measurements. The constants generated from this test are stored in non-volatile memory and are retained even after you turn off the tester.

To calibrate the CopperPro, complete the following:





1. Press  then  to display the **USER OPTIONS** menu (Figure 3-4).
2. Select **Zero Leads**. Press .
3. As instructed, connect the Pair 1 and Ground test leads together, then press .
4. When prompted, disconnect the test leads, then press .

If no faults are detected, a “Zero Leads Completed” message is displayed. If a problem with measurement values is detected, an error message describing the problem is displayed.

Turning the Backlight On and Off

When you use the tester in low light conditions, you can turn on the backlight for better viewing.

To turn the backlight on and off, press . This key is located halfway down the keypad on the left side of the front panel (see Figure 2-1).

To display the screen in reverse video so that it is easier to view in low-light conditions, press  then . To return to normal video, press  then  again.



Adjusting the Contrast of the LCD

To adjust the contrast of the LCD, complete the following

1. Press .

Note



This is the yellow Shift key, which is located in the lower right corner of the keypad (see Figure 2-1). In the lower left corner of the screen, the word “Shift” appears to indicate that the tester is in Shift mode.

2. Press  to decrease the contrast or  to increase the contrast.
3. After the level of contrast is acceptable to you, press  again to save the setting.

Adjusting the Volume of the Speaker

The CopperPro has a speaker that emits a distinctive sound when a key is pressed or when certain testing operations are being performed.

To increase or decrease the volume of the sound, do the following:

1. Press . Then, press  to increase the volume or  to decrease the volume.

When you press the arrow key, the speaker emits a tone at the newly adjusted volume, giving you a sample of the level of sound.

2. When the volume is acceptable to you, press  again.

The new setting is saved in memory and remains in effect even after you turn off the tester.

Displaying System Information

To find out what version of software you have or what options are installed on the tester, complete the following:

1. Press  then  to display the **USER OPTIONS** menu (Figure 3-4).
2. Select **System Version**. Press .

The **System Version** screen displays the following information about the tester:



- Software version loaded
- Top assembly hardware revision
- Installed options (if any).

Operating the Tester as a Dial Set

To operate the CopperPro as a dial set, do the following:

1. Turn on the CopperPro.
2. Connect the **T** (Tip) and **R** (Ring) test leads to a working POTS line. If the line is a ground-start line (as opposed to loop-start), connect the **G** (Ground) test lead to the cable sheath or C.O. ground.
3. Press .

The **Dialing Mode Selection** screen is displayed.

4. Do one of the following:
 - To automatically dial the number, press  (**Auto-Dial**). Select the number from the list, then press .
 - To manually dial the number, press  (**Manual Dial**). Then, dial the number from the keypad.
5. When you finish dialing, turn the tester over.

You can now use the speaker and microphone as a standard handset.

Note

If the volume of the speaker needs to be adjusted, see “Adjusting the Volume of the Speaker”, earlier in this chapter.





Running a Self-Test

The self-test is a rigorous test of the internal CopperPro hardware. It is a good idea to periodically run a self-test to verify that your tester is operating properly. If the self-test fails, a diagnostic message is displayed.

The CopperPro has the following self-tests:



- POTS self-test
- WB self-test
- TDR self-test

To run a self-test, complete the following:

1. Press  then  to display the **USER OPTIONS** menu (Figure 3-4).
2. Select **Self-Test**. Press .
3. Press the softkey for the self-test that you want to run. Then, press .

Printing Displayed Results and Setup Information

You can print any setup information or test result screen that is currently displayed on the tester's LCD. To do this, follow these steps:



1. Connect one end of the optional serial printer cable to the CopperPro's RS-232 port. Connect the other end to the serial printer.
2. Select the printer type in User Options, "RS232 Port Setup".
3. Display the setup or result screen that you want to print.
4. Press  then  ("Print Screen" alternate function).
5. Press  (**Printer**) to print the screen to the connected printer.

The contents of the currently displayed screen are sent to the printer.

If you want to print test results that are saved in the tester's memory, see "Saved Test Results" in Chapter 7.

Transferring a Screen Image to a PC

To transfer any screen image to a PC in the in the “.BMP” file format (for viewing or printing to a non-supported printer):

1. Connect the supplied serial cable to the CopperPro’s serial port and a PC COM port.
2. Display the desired CopperPro screen for transfer.
3. On the PC, open a standard ASCII data communications program (HyperTerminal, TeraTerm, etc.). Set up the program as follows:
 - Baud Rate = 38,400 bps.
 - 8 Data bits, 1 Stop bit, No Parity.
 - Set data transfer mode to the XMODEM Receive File format, with CRC enabled.
 - Name the file with a “.BMP” file extension.
4. On the CopperPro, press , then  (“Print Screen” function). A message is displayed prompting you to start the file transfer.
5. Start the PC communications program XMODEM file transfer. The “.BMP” screen file begins transferring.
6. When complete, open the transferred file using a standard graphics program (for example, Microsoft Paint, Powerpoint, etc.).
7. The graphics file may then be viewed, or printed on any attached Windows-compatible printer.

Chapter 4

POTS Testing and Fault Location

Introduction

This chapter shows you how to use the CopperPro to identify and locate common physical problems on OSP copper pairs, and how to qualify lines for POTS service. The chapter begins by showing you how to set up and run a POTS Auto-Test. The POTS Auto-Test is comprised of a sequence of individual parametric tests that run automatically. Results from this test can give you a quick overall assessment of the performance characteristics of either a spare or working POTS pair.

The chapter then describes the individual tests in the POTS toolbox. This toolbox contains a group of specialized tests that provide detailed information to help you diagnose specific problems in a cable. In the POTS toolbox, you will find two groups of tests: copper media (DC) tests and transmission (AC) tests. The copper media tests are designed to identify and locate physical voltage, resistance, and capacitance faults, and test for continuity in a cable. The transmission tests provide accurate measurements of signal loss, metallic noise, power influence, and longitudinal balance to help you uncover root problems affecting signal transmission.

POTS Auto-Test

The POTS Auto-Test is a sequence of user-selectable *single-ended* parametric and transmission tests. The test can be run on *either* spare or working POTS pairs, with the appropriate selected tests automatically performed. It is an ideal tool to qualify POTS pairs, as well as providing an overview for fault analysis.

Table 4-1 lists the individual tests that comprise the POTS Auto-Test. All but the first two tests are user selectable, which gives you the flexibility to customize an Auto-Test that fits your particular testing situation.

Setting Up a POTS Auto-Test

To set up a POTS Auto-Test, complete the following:

1. From the **Main** menu, select the **POTS Auto-Test**.
2. Press **[4]**(**Setups**).

The **Setups–POTS Auto-Test** screen 1 (Figure 4-1) is displayed:

Setups - POTS Auto-Test			
Facility Cable No. :	NPG5804		
Pair/Terminal No. :	1001		
CopperPro Pair No. :	1		
Opens	:	Y	
Load Coils	:	\bar{Y}	
Loop Devices	:	\bar{Y}	
VF Long. Balance	:	\bar{Y}	
Loop Current	:	\bar{Y}	
VF Noise	:	\bar{Y}	
VF Loss	:	\bar{Y}	
Edit		More	Restore Defaults

Figure 4-1. POTS Auto-Test Setup Screen 1

acy11s.eps

Two groups of setup parameters are listed on this screen. The first group consists of the generic setup parameters, and the second group lists the tests that you can run under the POTS Auto-Test (refer to Table 4-1).

3. If desired, supply a value for each generic setup parameter.

Note

Table 3-1 describes the generic setup parameters. If you need instructions for changing their values, see “Editing the Setup for a Test” in Chapter 3.

4. Select the tests that you want to include in the Auto-Test. For each test, do the following:
 - a) Press \uparrow or \downarrow to select the test. Then, press (**Edit**).
 - b) Press \uparrow or \downarrow to select **Y** if you want to include the test or **N** if you do not want to include the test.
 - c) Press to save your selection.

Note

*To restore the factory default values of the setup parameters, press (**Restore Defaults**).*

To change the setup for any of the individual tests, see “Editing the Setup for a Test” in Chapter 3. Individual test default settings are for POTS service qualification.

There is a second screen of setups for the POTS Auto-Test, accessible by pressing (**More**). Table 4-1 lists the tests you can include in the POTS Auto-Test, plus other setup parameters on the second setups screen.

Table 4-1. User Selectable Tests for the POTS Auto-Test



Test	Description	Settings (default in bold)
Voltage	Measures AC and DC voltages on all legs of spare or working pairs.	No choice, always run.
Shorts & Grounds	Measures resistance between all legs of spare pairs.	No choice, always run. (N/A on working pairs)
Opens	Measures capacitance on spare pairs, converting to distance based on the Cable Type selected.	Select Y to enable the test Select N to disable the test. (N/A on working pairs)
Load Coils	Detects the number of coils and approximate distance to the first, on spare or working POTS pairs, plus a frequency response graph.	Select Y to enable the test Select N to disable the test.
Loop Devices	Detects the presence of loop treatment devices, fault-sectionalizing devices, and Mechanical Bell Ringers on spare or working POTS pairs.	Select Y to enable the test Select N to disable the test.
VF Long. Balance	Measures resistive and capacitive balance of the pair to Ground, on spare or working POTS pairs.	Select Y to enable the test Select N to disable the test.
Loop Current	Measures Loop Current, Ring-Ground Current, and cable sheath Ground resistance on working POTS pairs.	Select Y to enable the test Select N to disable the test. (N/A on spare pairs)

Table 4-1. User Selectable Test for POTS Auto Test (continued)

Test	Description	Settings (default in bold)
VF Noise	Measures Metallic Noise and Power Influence on spare or working pairs. Measures Dial-up Noise if QT number entered in Setup screen 2.	Select Y to enable the test Select N to disable the test.
VF Loss	Measures Dial-up VF Loss on working POTS pairs, if Milliwatt number entered in Setup screen 2.	Select Y to enable the test Select N to disable the test. (N/A on spare pairs)
VF Noise Quiet Term. #	Quiet Termination phone number. (Setup screen 2)	Enter number to enable test on working POTS pairs.
VF Loss Milliwatt #	Milliwatt or N-Tone sweep number. (Setup screen 2)	Enter number to enable test on working POTS pairs.
VF Noise Test Delay	Post-dialing delay prior to running VF Noise test. (Setup screen 2)	Enter number of seconds to delay after dialing, prior to running test.
VF Loss Test Delay	Post-dialing delay prior to running VF Loss test. (Setup screen 2)	Enter number of seconds to delay after dialing, prior to running test.
Cable Type	Required by Opens test	Select from Cable Type list
Cable Gauge	Required by Load test	Select from Cable Ga. list
Cable Temperature	Required by Load test	Enter Cable Temperature

Starting and Stopping a POTS Auto-Test

You can start a POTS Auto-Test in one of two ways:

- From the **Main** menu (Figure 3-2), select **POTS Auto-Test**. Then, press .
- OR
- From the **Setups - POTS Auto-Test** screen, press .

The POTS Auto-Test begins, running each of the tests that you specified in the setup.

To stop a POTS Auto-Test at any time, press .

POTS Auto-Test Results

While the Auto-Test is running, the CopperPro displays the test it is currently performing. When it is completed, a Test Summary screen is displayed, showing each test and whether it passed or failed, as shown in Figure 4-2:

POTS Auto-Test		Acceptable AC Voltage	
TEST		Results	
AC Voltage		: Pass	
DC Voltage		: Pass	
Shorts & Grounds		: N/A	
Opens		: N/A	
Long. Balance		: Pass	
Metallic Noise		: Pass	
Power Influence		: Pass	
Load Coils		: No	
Loop Devices		: No	
Loop Cur. & Gnd Ω		: Pass	
VF Loss/Slope		: Pass	
Details		Save Results	Setups

Figure 4-2. POTS Auto-Test Summary Results

acy101s.eps

Note

“N/A” in the **Results** column indicates that the test was selected but not run because of excessive voltage or resistance on the pair.
“N/S” indicates the test was not selected in Auto-Test Setups.

If one or more tests fail, the cursor is positioned on the first failed test. The failed test is highlighted in steady, reverse-video format, with a flashing “FAIL” indicator. If all tests pass, the cursor is positioned on the first test in the list, and that test is highlighted.

To view the summary result for a test, press \uparrow or \downarrow to scroll through the list of tests. As the cursor is positioned on the name of a test, it is highlighted and its summary result is displayed in the upper right corner.

To view the details behind a summary result, press \uparrow or \downarrow to position the cursor on the name of the test, then press \square_1 (**Details**).

To page directly to the next test “Details” screen, press \downarrow .

To view the setup for a test, press \uparrow or \downarrow to position the cursor on the name of the test, then press \square_4 (**Setups**).

Saving POTS Auto-Test Results

Auto-Test results, unlike individual test results, are *not* automatically saved. To save the POTS Auto-Test results, do the following:

1. From the Test Summary screen, press \square_5 (**Save Results**).
2. Enter the following Test Identification information:
 - Job # (enter up to 16 alphanumeric characters)
 - Cable (enter up to 16 alphanumeric characters)
 - Pair (enter up to 16 alphanumeric characters)
3. Press \square_2 (**Save Results**).

The POTS Auto-Test results are now saved as Text Results in non-volatile memory, with failing results flashing. In a printout, failing results are preceded by an “*” for easy identification.

The POTS Toolbox

The POTS Toolbox includes the same tests that are available in the Auto-Test (see Table 4-1) as well as other fault location tests. This section introduces the POTS toolbox tests, shows you how to run them, and describes their results.

Starting and Stopping a Test in the POTS Toolbox

- From the **Main** menu, press **[POTS]** to display the POTS toolbox (Figure 4-3). Press an arrow key to select the desired test, then press **[TEST]**.

OR

- Display the setup menu for the desired test (see “Displaying a Setup Menu” in Chapter 3), then press **[TEST]**.

To stop a running test, press **[TEST]**.



Voltage	Shorts & Grounds	Opens	R.F.L.
Load Coils	Leakage Stress	Loop Devices	Tracing Tone
VF Noise	VF Loss	VF Long. Balance	Send VF Tone
POTS Auto Test	Dial-up Tests	Terminated VF Tests	Loop Cur. & Gnd Ω
<p>(Measure AC & DC Voltage)</p> <p>Press TEST to Start</p>			
POTS 	XDSL 	TDR 	Setups

Figure 4-3. POTS Toolbox

acy14s.eps

Voltage Test

The Voltage test gives you a “snapshot” measurement of AC and DC voltages on each leg of a pair. The test can identify hazardous voltage, an idle or busy POTS line, a Special Service circuit “footprint”, or a cross-to-battery fault.

Setting Up a Voltage Test

To set up a Voltage test, follow the instructions under “Displaying a Setup Menu” in Chapter 3. Refer to Table 4-2 for Voltage test setup parameters.

Table 4-2. Voltage Test Setup Parameters

Parameter	Settings (default in bold)
ACV Hazard. Volt Threshold	≥ 50 VAC (Range = 40 to 120)
ACV Pass Thresholds - TR:	≤ 3 VAC (Range = 1 to 30)
TG & RG:	≤ 25 VAC (Range = 1 to 30)
DCV Hazard. Voltage Threshold	≥ 190 VDC (Range = 70 to 200)
DCV Pass Threshold	≤ 3 VDC (Range = 1 to 20)
DCV Test Impedance	100 KΩ (Std. Telephony impedance) 1 MΩ (Compatible with 965DSP) 10 MΩ (Compatible with DVMs)
DCV Idle POTS Voltage Range	High side = -60 to -44 VDC Low side = 4 to -4 VDC (Range = 0 to ± 99 VDC) (Absolute value of Low < High)
DCV Busy POTS Voltage Range	High side = -44 to -26 VDC Low side = -4 to -25 VDC (Range = 0 to ± 99 VDC)

Voltage Test Results

To run a Voltage test, follow the instructions under “Starting and Stopping a Test in the POTS Toolbox”, earlier in this chapter. When completed, voltage results for all legs are displayed as shown in Figure 4-4:

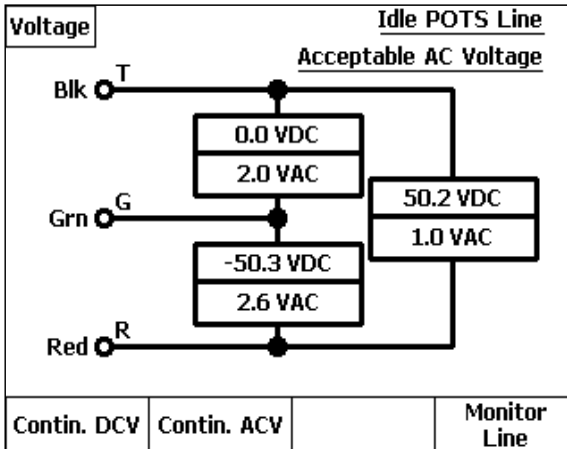

acy15s.eps

Figure 4-4. Voltage Test Results: Idle POTS Line

An Idle POTS line was detected in this test, as is shown in the status area in the upper right corner. Also, voltage readings are reported that are outside the acceptable limits for a spare pair (as defined in Setups). These readings are shown on the diagram in flashing, reverse video format for emphasis.

From the result screen, you can do the following:

- Press **[1]** (**Contin. DCV**) to obtain continuously updated DCV values for any selected leg (see “Running a Continuous Voltage Test” for details).
- Press **[2]** (**Contin. ACV**) to obtain continuously updated ACV values.
- Press **[4]** (**Monitor Line**) to non-intrusively monitor the pair using the tester’s built-in speaker (see “Monitor Line Test” later in this chapter).

Running a Continuous Voltage Test

To continuously monitor DC voltage on a pair, do the following:

1. Press (**Contin. DCV**).

The **Continuous DCV** screen (Figure 4-5) is displayed.

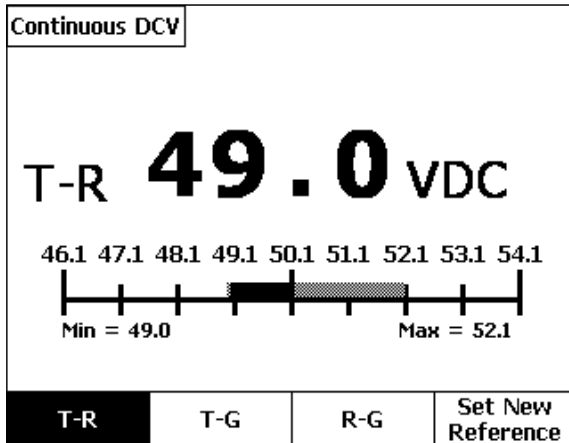

acy16s.eps

Figure 4-5. Continuous Voltage Test Result Screen

Figure 4-5 shows a continuous DCV value for the T-R leg. The bar graph plots real-time voltage variations against the reference (center) value of the initial reading. Peak voltage excursions are recorded as half-tone shaded portions of the bar, with excursions beyond the scale marked as “Min” and “Max” values. The current reading is shown in large, solid black numbers. Each scale mark on the bar graph corresponds to one unit of measure (in this case, 1 volt) of the parameter.

2. To continuously test another leg, press (**TG**) or (**RG**).
3. To re-center a reading that has drifted, press (**Set New Reference**).
4. To stop a continuous test, press or .

Shorts & Grounds Test

The Shorts & Grounds test provides a “snapshot” measurement of the resistances between each leg (TR, TG, and RG) of a pair.

Setting Up a Shorts & Grounds Test

To set up a Shorts & Grounds test, follow the instructions under “Displaying a Setup Menu” in Chapter 3. Refer to Table 4-3 for test setup parameters.

Table 4-3. Shorts & Grounds Test Setup Parameters

Parameter	Settings (default in bold)
Resist. Fault Pass Threshold	\geq 150 K Ω (Range = 2 to 9999)
Cable Gauge	19, 22, 24 , 26, or 28 AWG
Cable Temperature	68 ° F (Range = -99 to 199)

Shorts & Grounds Test Results

To run a Shorts & Grounds test, follow the instructions under “Starting and Stopping a Test in the POTS Toolbox”, earlier in this chapter.

In Figure 4-6, the Shorts & Grounds test detected a short (**Tip-Ring Short**) on the pair. The test also reports a fault resistance reading (**500 Ω**) that is outside the acceptable limits (as defined in the setup for the test). This reading is shown in flashing, reverse video format.

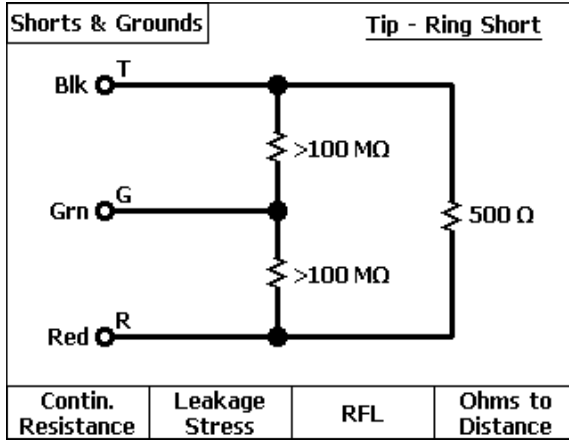

acy17s.eps

Figure 4-6. Shorts & Grounds Test Results: Short

To run additional tests directly from this screen, do the following:

- Press **(Contin. Resistance)** to obtain a continuous resistance reading.
- Press **(Leakage Stress)** to run a high voltage test to break down and expose high resistance oxidized copper faults. (See “Leakage Stress Test”)
- Press **(RFL)** to run a Resistance Fault Location test to locate the fault.
- Press **(Ohms to Distance)** to convert the fault resistances to distances. (See “Converting Fault Resistance Values to Distance Values”, which follows, for instructions).

Converting Fault Resistance Values to Distance Values

Often the fault resistances displayed are “hard” shorts or grounds, meaning that the fault is at zero Ohms, and the resistance shown is only the conductor resistance itself to that fault. In these situations, the CopperPro can convert the resistances to distances—if you supply the cable gauge and temperature.

To convert the fault resistance values to distances, complete the following:

1. On the Shorts & Grounds result screen, press (**Ohms-to-Distance**).
2. If the cable gauge or temperature is different from that specified in the setup for the test, do the following:
 - If the pair consists of only one gauge, press (**Setups**), and select the proper gauge and temperature. Then press .
 - If the pair consists of more than one gauge, press (**Multiple Gauge**). Then enter each section length and gauge (see “Entering Multiple Wire Gauge Information” for details). When done, press to return to the resistance display.
3. Press (**Convert to Distance**) to display the distances.

Opens Test

The Opens test performs a true three-terminal test on a pair. To run the test, you need to choose the appropriate Cable Type (see Table 4-4).

Note

You do not need to provide the "D" Factor (or TG /TR Capacitance Ratio) or have to ground a percentage of spares in the cable to get an accurate distance reading, as you do with conventional 2-terminal meters. The CopperPro actually measures the Capacitance Ratio of the pair during the Opens Test.

The Opens Test performs a measurement of the capacitive length of the pair, as well as the capacitive balance between the Tip and Ring conductors.

Setting Up an Opens Test

To set up an Opens test, see the instructions under “Displaying a Setup Menu” in Chapter 3. Refer to Table 4-4 for setup parameters for the Opens test.

Table 4-4. Opens Test Setup Parameters

Parameter	Setting (default in bold)
Cable Type	Jelly Filled , Air Core, JKT, 5 Pr. Buried Drop, 2 Pr. Buried Drop, 1 Pr. Aerial Drop, 1 Pr. Universal Drop, or Custom.
Cap. Balance Pass Threshold	≥ 95 % (Range = 0 to 99)

Opens Test Results

To run an Opens test, see “Starting and Stopping a Test in the POTS Toolbox”.

Figure 4-7 shows a result screen from an Opens test that was conducted on a good, balanced pair:

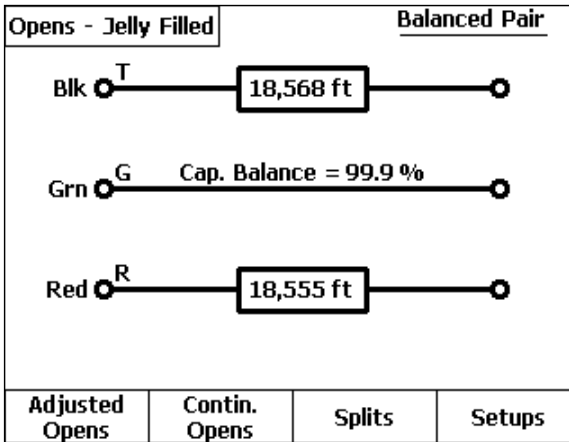

acy18s.eps

Figure 4-7. Opens Test Result: Good Pair

Depending on the results you obtain, you may want to run additional tests on the pair. From the Opens test results screen, you can do the following:

- Press (**Adjusted Opens**) to calibrate the pair to a known length or mutual capacitance value (see “Adjusted Opens Test” for details).
- Press (**Contin. Opens**) to run the test continuously on a selected leg.
- Press (**Splits**) if the pair is known to be a split pair (see “Splits Test” later in this chapter).

Adjusted Opens Test

A cable manufacturer's data can vary by as much as 7% among cables. Therefore, for greater accuracy, it is strongly recommended that you first perform an Opens test on a *known good* pair in the cable. This data can then be saved as a Custom Cable Type for further use on faulted pairs in the same cable. Alternatively, if the length of a good pair is known by another more accurate means, you can enter that length and store the data as a Custom Cable Type. This is called an *Adjusted Opens* measurement.

Figure 4-8 shows the results from a balanced pair being used to create a Custom Cable Type for future usage on other pairs in the same cable

To run an Adjusted Opens test, do the following:

1. Run an Opens Test on a good, balanced pair in the cable.
2. Press (**Adjusted Opens**).

A screen like the one in Figure 4-8 is displayed:

Opens - Jelly Filled			
<p>Cable Length : 18570 ft</p> <p>3T Cap. Ratio (TG/TR) : 1.68</p> <p>Cap. Reference (mutual) : 0.08300 µF/mi</p>			
Adjust			Save as Custom

Figure 4-8. Adjusted Opens Test Screen

acy19s.eps

3. If the **Cable Length** value is *not* correct:
 - Press (**Adjust**), then enter a known good value for **Cable Length** (five digits maximum, no commas), and / or a **Cap. Reference** value if known to be non-standard.
 - When finished, press (**Save as Custom**) to create a Custom Cable Type based on the entered data, using the same **3T Cap. Ratio** value as measured on the good pair.
4. If the **Cable Length** value *is* correct:
 - Press (**Save as Custom**) to create a Custom Cable Type with the same **3T Cap. Ratio** value as measured on the good pair.

Splits Test

The Splits test should be run if an Opens Test result shows a “Possible Split or Water” condition. However, a split condition may exist that is not detected by the Opens Test, due to the length of the split being fairly short. In this case, when the pair is known to be split but shows to be good and balanced, you should run the Splits Test.

Note

The Splits test provides the approximate distance to a split. To precisely locate a split, it is recommended that you run a TDR test (see Chapter 6 “TDR Testing and Fault Location” for details).

Figure 4-9 shows an Opens test results screen which reports a possible split.

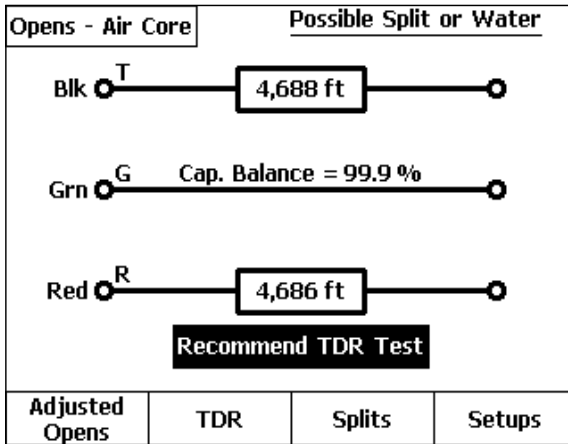

acy20s.eps

Figure 4-9. Opens Test Result Screen: Possible Split or Water

Notes

The “Possible Split or Water” result is generated whenever the 3T Capacitance Ratio (TG to TR) of a balanced pair is greater than the average ratio for the selected Cable Type. This may be due to either a split pair condition, enough water in the cable to alter its 3T Cap. Ratio, or a good pair having a non-standard 3T Cap. Ratio.

If the pair is a known good pair with a non-standard 3T Cap Ratio, you can create a Custom Cable Type with those characteristics by pressing (Adjusted Opens, then (Save as Custom). Subsequent tests on like pairs will result in the omission of the “Possible Split or Water” message.

To determine the approximate location of the split, proceed as follows:

1. On the Opens test result screen, press (Splits).

A connection diagram is displayed, as shown in Figure 4-10:

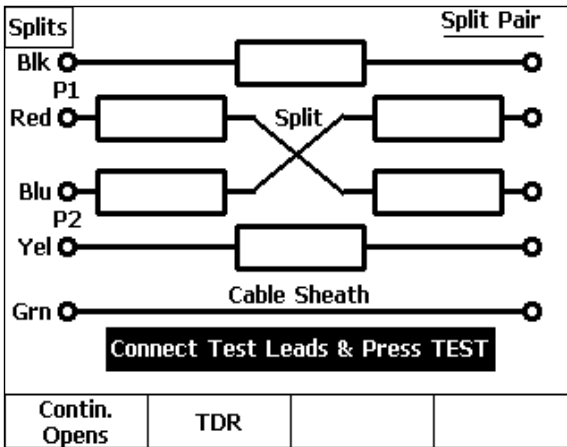

Figure 4-10. Splits Test: Connection Diagram

acy21s.eps

2. Verify that the pair is actually split with another pair, and then locate the second split pair with a tracing tone probe or other standard method.
3. As prompted, connect the CopperPro Pair 1 and 2 test leads to the two split pairs *exactly* as shown in the connection diagram (Figure 4-10).
4. Press

Note

The two split pairs must be the same lengths (within $\pm 5\%$) for the CopperPro to obtain a meaningful measurement. If not, the CopperPro detects the imbalance and displays an error message.

The CopperPro makes the required measurements, as shown in Figure 4-11:

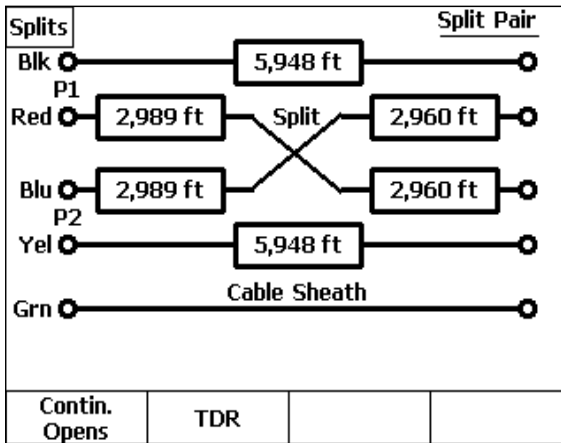

acy96s.eps

Figure 4-11. Splits Test Result Screen

5. Press (**Contin. Opens**) to view continuous two-terminal information, which includes the selected leg length or capacitance.
6. Press (**TDR**) to obtain a more accurate value of the distance to the split.

Resistance Fault Location (RFL) Test

The RFL test provides a highly accurate method of locating resistance faults (shorts, grounds, or crosses), including those that are *too large* for the TDR test to locate. It does this by using cable gauge and temperature values in a “nulling bridge” process. In this process, half of a resistance bridge is formed within the CopperPro, and the faulted pair (strapped at the far end, as prompted) forms the other half of the bridge. The internal bridge ratio is then changed until it precisely mirrors the ratio of the faulted leg to the good leg, and is then used to calculate resistance values to the fault and strap.

Setting Up an RFL Test



To set up an RFL test, follow the instructions under “Displaying a Setup Menu” in Chapter 3. Refer to Table 4-5 for RFL test setup parameters.

Table 4-5. RFL Test Setup Parameters

Parameter	Settings (default in bold)
Cable Gauge	19, 22, 24 , 26, or 28 AWG
Cable Temperature	68° F (Range = -99 to 199)
Multiple Gauge Entry Limits	Section Length (Range = 0 to 9999 ft.)
	Gauge / mm (Same as Cable Gauge)
	Load (Y or N)

Running an RFL Test

To run an RFL test, do one of the following:

- Select **RFL** in the POTS Toolbox (Figure 4-3), then press .
- OR
- From the **Setups - R.F.L.** menu, press .

The CopperPro locates the leg positions and values of all fault resistances, and then displays a screen that prompts you to connect a far-end strap (dotted line).

For a single-sided ground fault, the display will look like Figure 4-12:

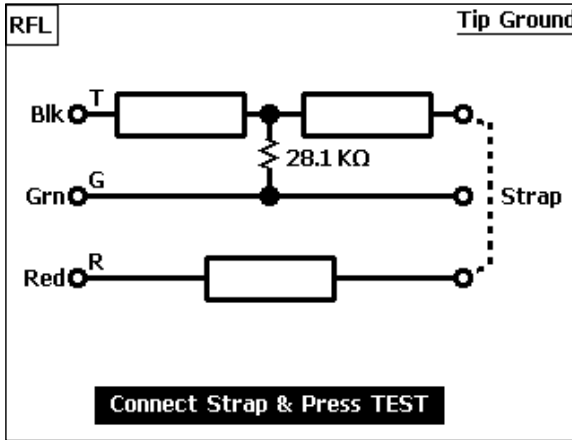

acy22s.eps

Figure 4-12. RFL Test Results: Fault Value and Position

If your screen is similar to Figure 4-12, go to “Single-Sided Fault Location Test Results” for instructions on how to obtain the distance to the fault.

If the fault is a short or if both conductors are faulted, or a shorting strap *has already been placed at the far end* for a single-sided fault, the tester displays a screen like Figure 4-13:

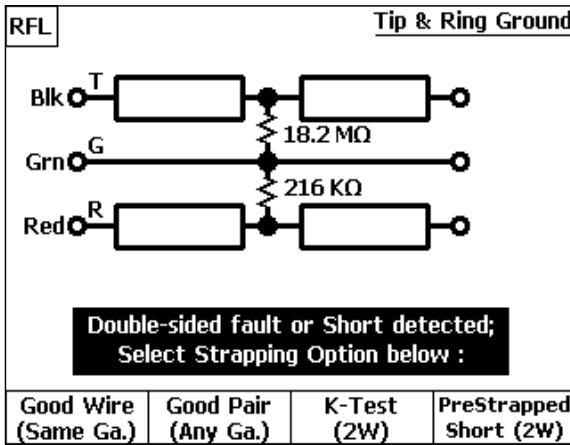

acy25s.eps

Figure 4-13. RFL Test Results: Double-sided Fault or Short

If your screen is similar to the one in Figure 4-13 and you *have not already connected* a far-end strap, go to “Short or Double-Sided Fault Location Test Results” for instructions on how to strap the pair and complete the test.



If your screen is similar to this and you *have already placed* a far-end T-R shorting strap for location of a single-sided fault, press (**Pre Strapped Short (2w)**) and continue below with step 2.

Note

The far end of a double-sided fault or short may be pre-strapped with a good wire or pair prior to running the RFL test, with no change in procedures.

Single-Sided Fault Location Test Results

To locate a single-sided fault, do the following:

1. Connect the strap as shown in Figure 4-12, then press .
2. If the tester was turned off during the strap connection process:
 - Turn it on, and select RFL again from the POTS Toolbox.
 - Select  (Continue Prev. Test), then press .

If the strap is not detected, a “Strap Connection Error” message is displayed.

If the strap is properly connected, the CopperPro performs a “fault null” operation and displays a screen similar to the one in Figure 4-14.

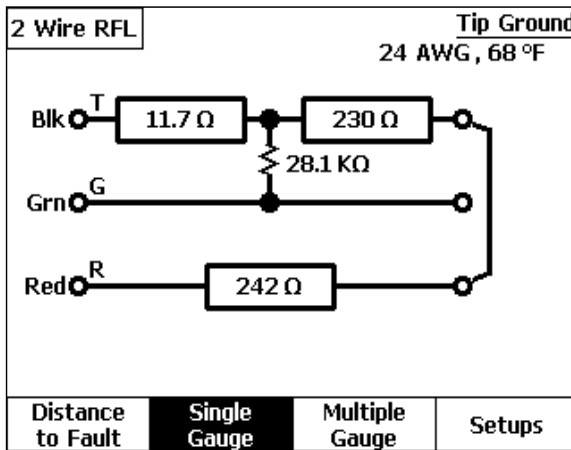

acy23s.eps

Figure 4-14. Two-Wire RFL Test Results: Tip Ground

Figure 4-14 shows the conductor resistance values to the fault, and from the fault to the strap (shown in the diagram as a solid line).

3. If you supplied the correct gauge and temperature information in RFL Setups prior to running the test, press **[1]** (**Distance to Fault**).
4. If the correct gauge and temperature were not entered into Setups prior to the test, you can enter them now. Press either **[4]** (**Setups**) to enter single-gauge and temperature information, or **[3]** (**Multiple Gauge**) to enter multi-gauge section information. When finished, press **[BACK]**, then **[1]** (**Distance to Fault**).

The relevant distances are displayed, as shown in Figure 4-15.

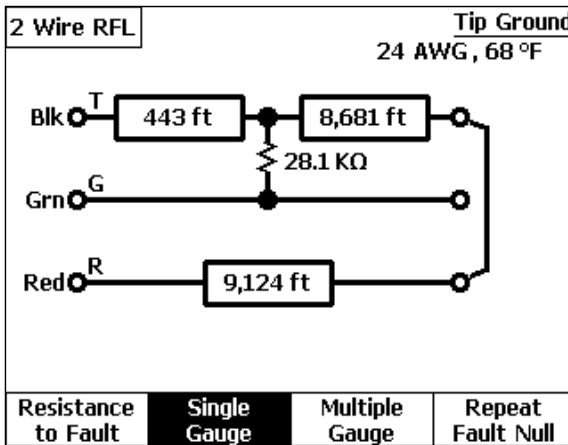

acy24s.eps

Figure 4-15. Two-Wire RFL Test Results: Distance to Fault

5. If you want to obtain a second reading with the test leads connected to the same pair, press **[4]** (**Repeat Fault Null**). The CopperPro repeats the nulling process without again measuring fault resistances.

Entering Multiple Wire Gauge Information

For pair counts composed of multiple wire gauge sections, or sections containing load coils, use this procedure to store multiple gauge information.

The CopperPro lets you store up to 20 “sections” of data. A section is defined as a length of cable having a gauge that is different from the preceding length, or a length of cable containing a load coil at the end.

To enter multiple wire gauge information, do the following:

1. On either the **Setups - RFL** or an RFL Test Results screen, press (**Multiple Gauge**).

An entry screen is displayed. The **Length** field is highlighted.

2. Press (**Edit**).

A blinking cursor appears in the first character position of the **Length** field as shown in Figure 4-16:

2 Wire RFL				
Section	Length	Gauge	Load Coil	Strap Dist.
1.	0	24 AWG	N	N
2.	0	24 AWG	N	N
3.	0	24 AWG	N	N
4.	0	24 AWG	N	N
5.	0	24 AWG	N	N
6.	0	24 AWG	N	N
7.	0	24 AWG	N	N
8.	0	24 AWG	N	N
9.	0	24 AWG	N	N
10.	0	24 AWG	N	N
Edit	Insert Section	Delete Section	MORE ⇅	

acy32s.eps

Figure 4-16. RFL Multiple Wire Gauge Entry Screen

3. Enter the length of the first section (five digits maximum, with no commas), using the same units of measure (feet or meters) selected for the Language configuration, then press .
4. Press to move the cursor to the Section 1 **Gauge** field.
5. Press (**Edit**), press or for the desired gauge, then press .
6. Press to move the cursor to the **Load Coil** field.
7. Press (**Edit**), and press or to select **Y** if a load coil terminates the section or **N** if it does not. Then, press .
8. Press to move the cursor to the **Strap Dist.** field.
9. If the Section 1 length entered is the actual *known* distance to the strap, press or to select **Y**. Otherwise select **N**, and press .
10. Press to move the cursor to the Section 2 **Length** field.
11. Repeat Steps 2-7 until you enter information for all of the sections. When you finish, press to return to the **RFL** results screen.

Note

*It is important to make sure that the last section that you enter contains the strap position. If an “**Insufficient Length Entered**” message is displayed when you press the key to exit the Multi-gauge Entry screen, it is because the sum of the entered lengths is shorter than the Distance-to-Strap length measured by the CopperPro. In this situation, first verify that the entered **Length** and **Gauge** information is correct. If so, increase the length you entered for the last section. This change does not affect the accuracy of the results, but allows agreement between the entries and measurements.*

Deleting or Inserting a Wire Gauge Entry

To delete the information in a complete Section number line, select the desired section using or , then press (**Delete Section**).

To insert a section, position the cursor to the section above which you want to add a line, and press (**Insert Section**).

RFL Test “Distance to Strap” Entry

If the distance to the strap was known and entered into Section 1 of the above Multiple Gauge entry screen (along with **Y** in the **Strap Dist.** field), *all other section data will be ignored*. The RFL fault distances will then be based on a wire resistivity that is calculated from the entered strap distance.

Note

If the cable contains one or more gauge changes between the CopperPro and the far-end strap, the average resistivity calculated from the entered strap distance could result in inaccurate distance-to-fault or fault-to-strap readings, depending on the relative lengths of the different gauges.

Short or Double-Sided Fault Location (3 Wire) Test Results

To view test results for a short or double-sided fault, select the desired strapping option to complete the bridge (as prompted in Figure 4-13).

Note

*If the fault is a short or if both conductors are faulted, you must use either a good conductor or pair to complete one leg of the bridge. It is best to use a separate good pair for the leg because it can be **any length or gauge**. If only one good conductor is available, it can work as well, but it must be the **same length and gauge** as the faulted pair.*

Do one of the following:

- If only one good conductor is available, press (Good Wire-Same Ga.), and a connection diagram like that shown in Figure 4-17 is displayed:

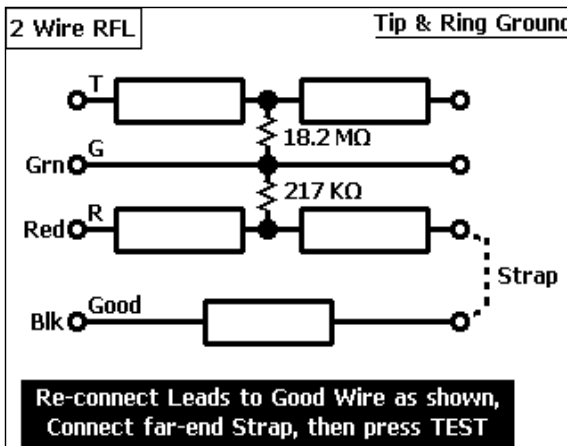

acy29s.eps

Figure 4-17. Two-Wire RFL Test Results: Good Wire Strap

- As prompted, reconnect the leads to the good wire and connect the far-end strap. Then, press .

When the test finishes, resistance values are displayed.

- b) Press (**Distance to Fault**), and distances to the fault and strap are then displayed, as shown in Figure 4-18:

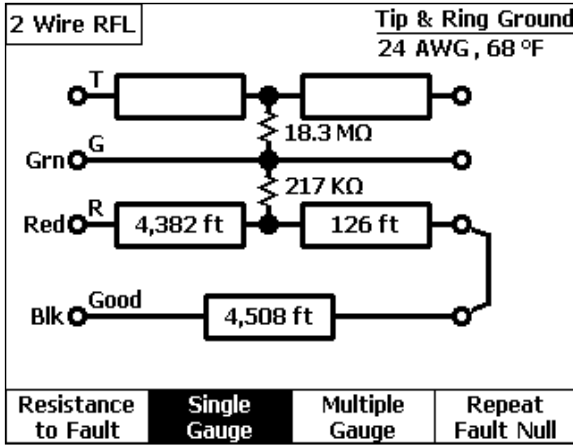

acy30s.eps

Figure 4-18. Two-Wire RFL Test Results: Distances

OR

- If a good pair is available, press (**Good Pair-Any Ga.**), and a connection diagram like the one shown in Figure 4-19 is displayed.

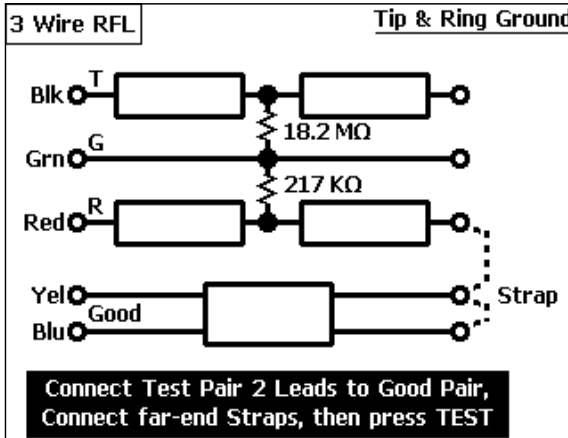

acy26s.eps

Figure 4-19. Three-Wire RFL Test: Good Pair Strap

This diagram shows the T1 and R1 test leads connected to the good pair and a far-end strap (in dotted lines).

To complete the test, do the following:

- a) Connect the Pair 2 test leads (T1 and R1) to the good strapping pair and connect the far-end straps, then press .

The CopperPro runs the test using the separate good pair as the strap. When completed, resistances to the fault and strap are displayed.

Note

The 3W RFL test is slightly longer because the tester has to run the nulling bridge process on both the strap and the faulted pair.

- b) Press  (**Distance to Fault**), and distances to the fault and strap are displayed as in the example of Figure 4-20.

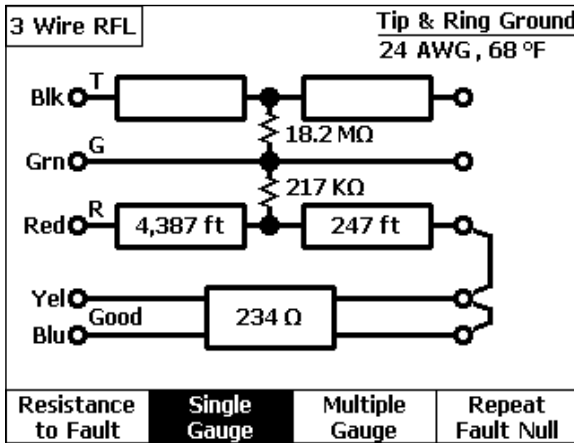

acy27s.eps

Figure 4-20. Three-Wire RFL Test Result: Distances

RFL Test: K-Test Option

The “K-Test” is a variation of RFL that can be used whenever a double-sided fault is present, *and there are no good conductors in the cable* to use for either the “Good Wire” or “Good Pair” strapping function.

K-Test Pair Requirements

1. Both resistance faults must be to the *same fault potential*, and occur at the *same physical place* on the cable.
2. The larger fault resistance must be *greater than twice* the smaller value.
3. The larger fault resistance must be at least *one hundred times greater* than the pair’s loop resistance.

Running the K-Test

After performing an initial RFL test on a pair having a double-sided fault, and whose values meet the K-Test requirements (as in Fig. 4-13), do the following:

1. Press (**K-Test-2W**).

The tester then runs the first part of the test, performing a nulling bridge operation on the pair *with the far end open*.

Note

If one fault resistance is not greater than twice the other, an error message is displayed at this point, and the K-Test cannot be run.

2. If the fault ratio requirement is met, the tester prompts you to connect a far-end T-R short. The unit may be powered down at this time, as with other RFL options, and the test resumed (**Continue Prev. Test**) after the short is connected.
3. With the strapping prompt screen displayed, press .

This starts the second part of the K-Test, during which the tester measures loop resistance and performs a nulling bridge operation on the pair *with the far-end shorted*.

After completion, the tester displays resistances to the fault and strap, as in the normal RFL process.

4. Press (**Distance to Fault**) to view distances, as is normally done.

Load Coils Test

The Load Coils test performs a frequency sweep of the pair (either spare or working POTS) to determine the number of load coils present, and the approximate distance to the first coil.

Setting Up a Load Coils Test

The Load Coils test requires that the *predominant* wire-gauge to the first load coil be entered in Setups, for the most accurate distance-to-first-load results.

Load Coils Test Results

To run this test, follow the instructions under “Starting and Stopping a Test in the POTS Toolbox” earlier in this chapter. Figure 4-21 shows the results of a Load Coils test that was conducted on a pair with six loads:

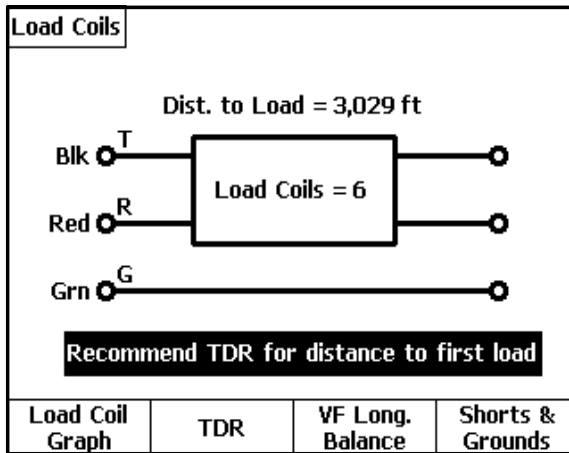
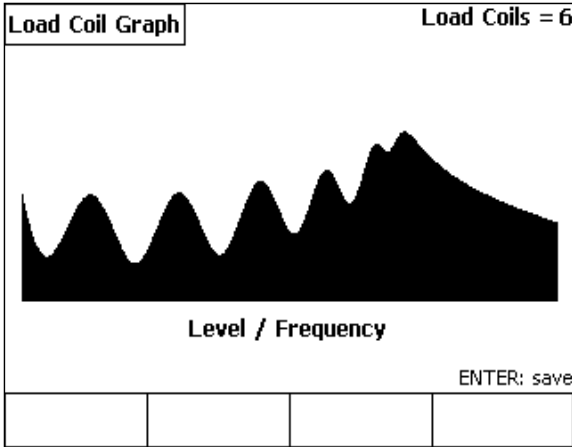

Figure 4-21. Load Coils Test Results

acy33s.eps

Figure 4-21 shows that six load coils were detected, with 3029 feet to the first. From this result screen, you can do the following:

- a) Press (Load Coil Graph) to view a frequency sweep graph of the test results, like that shown in Figure 4-22:



acy34s.eps

Figure 4-22. Load Coil Graph: 6 Loads

Each *negative dip* followed by a *positive peak* represents a single load coil. The pair depicted in Figure 4-22 has six sets of these dip-and-peak combinations, revealing the detected six loads. The farthest load is represented on the extreme right side of the waveform, and will always have a relatively smaller dip and peak.

Note

At times, small dips or peaks may be missed by the counter, yet be visually seen in the graph. Also, the presence of an abnormally high amount of metallic battery noise on working POTS lines may cause the counter to register a high false number of loads, but the actual number may be visually determined by looking at the graph.

- b) Press 2 (TDR) to go directly to the TDR menu, which allows a more accurate distance to the first coil to be measured.
- c) Press 3 (VF Long. Balance) to check for possible mis-loading due to the presence of half-loads.
- d) If a “Resistive Fault” message appears, press 4 (Shorts & Grounds) to measure the value of the fault.

Loop Devices Test

The Loop Devices test detects the presence of the following devices:

- Loop treatment devices on working POTS pairs such as Loop Extenders and Range Extenders with Gain (REGs).
- Fault-sectionalizing devices, such as Maintenance Termination Units (MTUs) and Network Interface Devices (NIDs).
- Mechanical Bell Ringers (C4 and C5).

Setting Up a Loop Devices Test

The Loop Devices test has no test-specific setups.

Loop Devices Test Results

To run this test, follow the instructions under “Starting and Stopping a Test in the POTS Toolbox”, earlier in this chapter.

Upon completion of the test, the CopperPro displays a result screen that lists each loop device and indicates whether or not it was detected on the test pair. A **Y** indicates that the device was detected, and an **N** indicates that the device was not detected.

Leakage Stress Test

The Leakage Stress test is a continuous resistance test that uses a higher test voltage than normal, in order to “punch through” a potential metallic wire fault that has oxidized over time. During normal resistance testing, this type of fault will not typically show up on a spare pair. However, it will gradually appear under sustained application of C.O. battery voltage after being cut into service as a supposedly “good” pair.

Setting Up a Leakage Stress Test

To set up a Leakage Stress test, follow the instructions under “Displaying a Setup Menu” in Chapter 3. The test has one setup parameter, which is listed in Table 4-6.

Table 4-6. Leakage Stress Test Setup Parameter

Parameter	Settings (default in bold)
Leakage Fault Pass Threshold	500 kΩ

Leakage Stress Test Results

To run this test, follow the instructions under “Starting and Stopping a Test in the POTS Toolbox”, earlier in this chapter.

Figure 4-23 shows results from a Leakage Stress test that was conducted on a faulty pair:

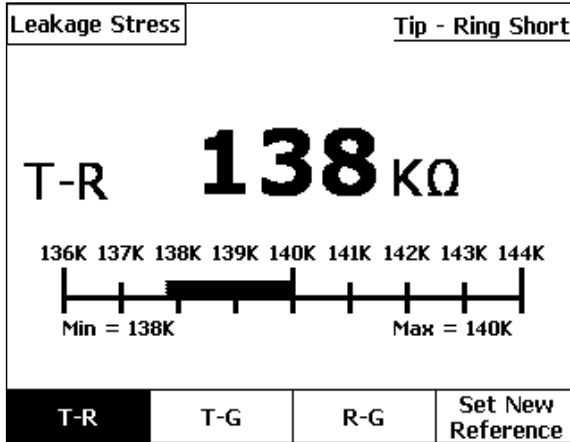

acy35s.eps

Figure 4-23. Leakage Stress Test Results: Faulty Pair

Note that the T-R resistance fault initially started at a reading of 140 kilohms, but during the applied stress voltage its value decreased to 138 kilohms. This reduction indicates the presence of a T-R short that has oxidized.

Under normal resistance fault testing, the T-R short would not be detected. After stress testing, a fault of this type usually remains long enough so that you can run an RFL test to determine its exact location.

1. Press 2 (**T-G**) to continuously stress the Tip-to-Ground leg.
2. Press 3 (**R-G**) to continuously stress the Ring-to-Ground leg.

Tracing Tone Test

The Tracing Tone test places a warbled, high-level ID tone on a test pair. You can choose to apply the following types of tones:

- **(Simplex)**: Tone applied equally on T & R with respect to G (non-intrusive)
- **(T-G)**: Tone applied only between Tip and Ground
- **(R-G)**: Tone applied only between Ring and Ground
- **(T-R)**: Tone applied only between Tip and Ring (audible).

Setting Up a Tracing Tone Test

The Tracing Tone test has no test-specific setup.

Running a Tracing Tone Test

To run a Tracing Tone test on a pair, do the following:

1. Select **Tracing Tone** from the POTS Toolbox, then press .
2. Press the softkey for the type of tone you want to apply, then press .
- A diagram depicting the selected mode is displayed. The transmitting arrow indicates that the tone is being applied.
3. To stop sending the selected tone, press .

VF Noise Test

This test performs a “snapshot” measurement of the voice frequency Metallic Noise (Nm) and Power Influence (PI) on the pair.

Setting Up a VF Noise Test

To set up a VF Noise test, follow the instructions under “Displaying a Setup Menu” in Chapter 3. Refer to Table 4-7 for VF Noise test setup parameters.

Table 4-7. VF Noise Test Setup Parameters

Parameter	Settings (default in bold)
Termination Impedance	600 Ω or 900 Ω
Termination Mode	Terminated or Bridged
Measurement Filter	C-Msg , C-Notched, 3K Flat, 15K Flat
Nm Pass Threshold	≤ 30 dBm (Range = 0 to 99)
Nm Pass Threshold	≤ 80 dBm (Range = 0 to 99)

VF Noise Test Results

To run this test, follow the instructions under “Starting and Stopping a Test in the POTS Toolbox”, earlier in this chapter.

Figure 4-24 is an example of a VF Noise test results screen. In this example, the pair has acceptable Metallic Noise (Nm), but the Power Influence (PI) value is above the acceptable threshold as defined in Setups.

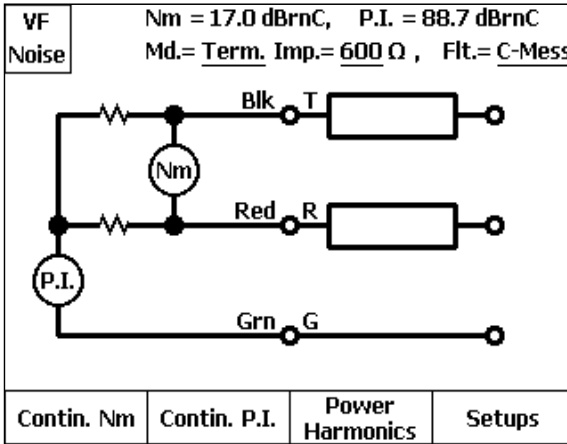

acy36s.eps

Figure 4-24. VF Noise Test Results

- a) Press (**Contin. Nm**) to run a continuous Metallic Noise test.
- b) Press (**Contin. P.I.**) to run a continuous Power Influence test.
- c) Press (**Power Harmonics**) to see the individual harmonic frequencies that combine to make up the Power Influence noise measurement.

Power Harmonics Test

The Power Harmonics test, available as a softkey test option on the VF Noise test result screen, shows values of both odd and even power frequency harmonics in the voice frequency band. After running the VF Noise test, press **3** (**Power Harmonics**) to obtain a snapshot graph of all power frequency harmonics on the line. The test is made from Tip and Ring to Ground, with no filter applied. There are no setups required for this test, and the fundamental frequency (50 / 60 Hz) is automatically derived from the selected Language / Country in **USER OPTIONS**.

Figure 4-25 illustrates a typical set of Power Harmonics on a working POTS pair with a normal degree of harmonics, due to inductive power line coupling.

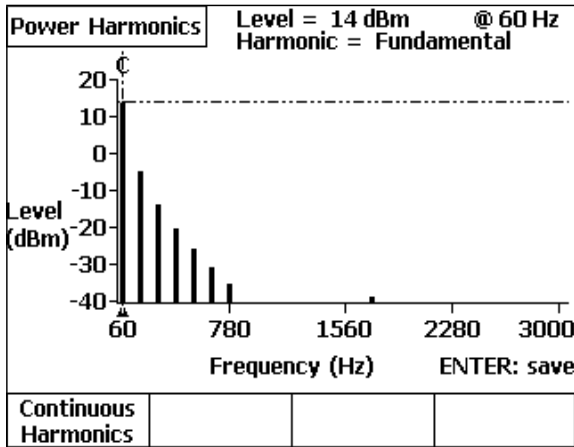

acy99s.eps

Figure 4-25. Power Harmonics Test Results

Note that the fundamental coupling frequency (60 Hz) is the largest signal present, as is normally the case when electromagnetic fields around power lines couple *inductively* into the telephone cable. With normal inductive coupling, the *odd harmonics* (3rd, 5th, 7th, etc.) are predominant, and have exponentially decreasing levels as shown in Figure 4-25.

Metallic coupling due to power line crosses will exhibit a high fundamental content, but will have little or no harmonic frequency content.

Coupling due to AC current in the cable sheath, caused primarily by large earth return currents from *unbalanced 3-phase power lines*, will exhibit high fundamental content as well as *both* odd and even harmonics.

Press (**Continuous Harmonics**) to view changing harmonics in real-time.

VF Loss Test

The VF Loss test requires that a manually-controlled VF transmitting device (such as another CopperPro or the C9925BLT) be connected at the far end of the pair. The device must be capable of transmitting single tones at a level of 0 dBm at 600Ω. The CopperPro measures the signal level at the near end and translates it into dB of insertion loss, assuming a 0 dBm transmit level.

Setting Up a VF Loss Test

To set up a VF Loss test, follow the instructions under “Displaying a Setup Menu” in Chapter 3. Table 4-8 describes the one setup parameter for the test.

Table 4-8. VF Loss Setup Parameter

Parameter	Settings (default in bold)
Termination Impedance	600 Ω or 900 Ω

Running a VF Loss Test

To run a VF Loss test, complete the following:

1. Select **VF Loss** from the POTS Toolbox, then press .

A connection diagram is displayed, as shown in Figure 4-26:

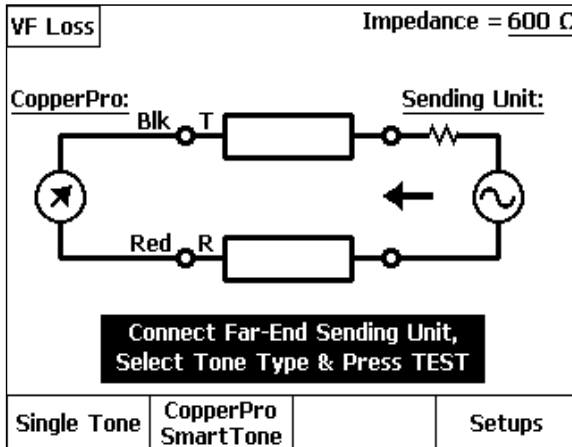

acy108s.eps

Figure 4-26. Connection Diagram for the VF Loss Test

2. Connect the far end sending unit as shown in the diagram.
3. Select (**Single Tone**) if the sending unit is to send a single frequency.
OR
4. Select (**CopperPro SmartTone**) if the sending unit is a CopperPro.
5. Instruct the sending unit to send the tone or tone-set, then press

VF Loss Test Results

The **Single Tone** VF Loss test measures the insertion loss of the pair at the detected frequency, and displays the result in the upper right corner of the screen as shown in Figure 4-27.

The **CopperPro SmartTone** loss test measures the 100-tone composite frequency set transmitted by another CopperPro, and displays a complete graph of the results. This test, in addition to being much faster than tests which send and measure one tone at a time, has enough resolution to catch significant faults (such as a loaded bridge tap) that can easily be missed by N-Tone loss /slope tests.

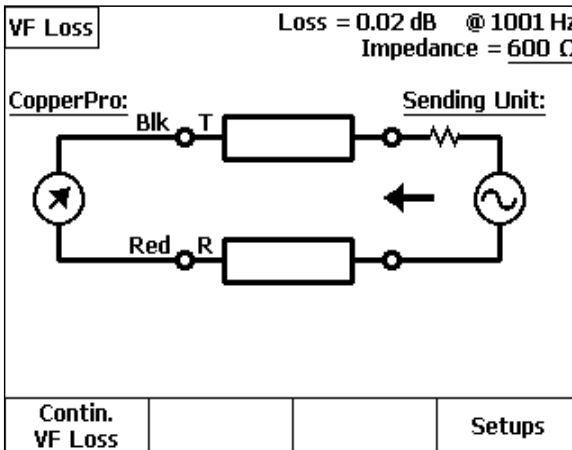

Figure 4-27. VF Loss Test Results

acy97s.eps

Press (Contin. VF Loss) to view continuous loss results.

VF Longitudinal Balance Test

This test applies a locally-generated common-mode disturbing tone to the pair, and simultaneously measures the metallic noise caused by this tone. Longitudinal balance is the difference in dB between the two signals.

Setting Up a VF Longitudinal Balance Test

Enter setup parameters as instructed in Chapter 3, referring to Table 4-9.

Table 4-9. VF Longitudinal Balance Setup Parameters

Parameter	Setting (default in bold)
Pass Threshold	≥60 dB (Range = 0 to 80)
Disturbing Frequency	1000 Hz (Range = 200 to 2500)

VF Longitudinal Balance Test Results

Figure 4-28 shows VF Longitudinal Balance test results on a good pair.

The Longitudinal Balance result is shown in the upper right corner of the screen, along with setup information.

Vg represents the locally applied disturbing tone, and **Vm** is the resulting metallic signal due to resistive or capacitive imbalance to Ground.

Longitudinal Balance (dB) = Vg (dBm) – Vm (dBm)

Press (**Contin. VF Long. Bal.**) to view continuous test results.

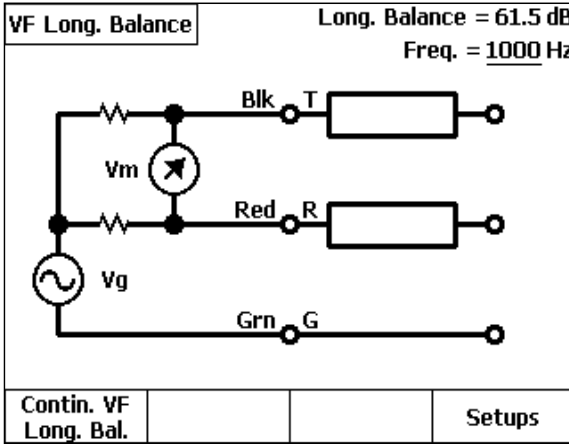

acy98s.eps

Figure 4-28. Longitudinal Balance Test Results: Good Pair

Send VF Tone Test

In this function, the CopperPro generates a variety of precision single tones, swept tone sets, or a composite VF tone set.

Setting Up a Send VF Tone Test

To set up a VF Tone, follow the instructions under “Displaying a Setup Menu” in Chapter 3. Refer to Table 4-10 for the setup parameter for this function.

Table 4-10. Send VF Tone Setup Parameter

Parameter	Setting (default in bold)
Term. Impedance	600 Ω , 900 Ω

Running a Send VF Tone Test

To send a VF Tone, do the following:

1. Select **Send VF Tone** in the POTS Toolbox, then press .
The **Send VF Tone** screen is displayed as shown in Figure 4-29.
2. Press the softkey for the desired tone (see Table 4-11 for descriptions).
Press (**More**) to view the second screen of tone selections.
3. Press , and the tester displays an arrow to indicate the tone is being sent.

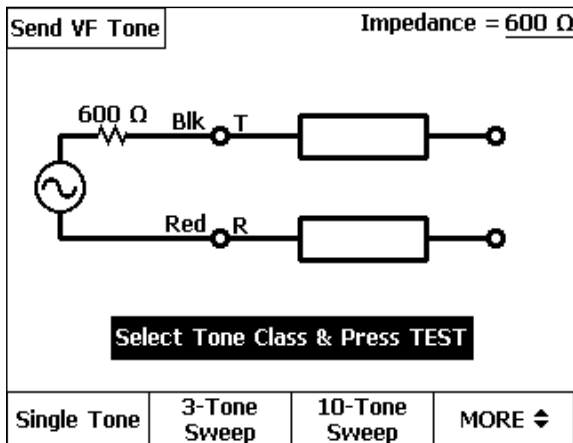

Figure 4-29. Send VF Tone Screen

acy38s.eps

Table 4-11. Types of VF Tones

Tone	Description
Single Tone	<ul style="list-style-type: none">• Continuously transmitted single tone• Settable level from +3 to -20 dBm• Settable frequency from 24 Hz to 20 kHz
3-Tone Sweep	<ul style="list-style-type: none">• Sequence of 3 tones, each lasting four seconds• 404, 1004, 2804 Hz• 0.0 dBm fixed level per tone
10-Tone Sweep	<ul style="list-style-type: none">• Sequence of 10 tones, each lasting three seconds• 404, 804, 1004, 1204, 1404, 1604, 1804, 2004, 2804, 3004 Hz• 0.0 dBm fixed level per tone
30-Tone Sweep	<ul style="list-style-type: none">• Sequence of 30 tones, each lasting two seconds• 304 Hz to 3304 Hz (in 100 Hz increments)• 0.0 dBm fixed level per tone
SmartTone	<ul style="list-style-type: none">• Composite signal (100 simultaneous tones)• 300 Hz to 3400 Hz, Preset levels

Loop Current & Ground Ohms Test

In the Loop Current and Ground Ohms test, the CopperPro measures and displays the following parameters on a working POTS line:

- **Loop Current** (into 430Ω)
- **Ring-Ground Current** (into 430Ω)
- **Ground Ohms** (Cable sheath resistance from measurement point to C.O.)

Setting Up a Loop Current & Ground Ohms Test

1. From the POTS Toolbox, select **Loop Cur. & Gnd Ω** and press **4** (**Setups**).
The **Setups – Loop Current & Ground Ohms** screen is displayed.
2. Enter the desired setup values, referring to Table 4-12.

Table 4-12. Loop Current & Ground Ohms Setup Parameters

Setup Parameter	Setting (default in Bold)
Loop Current Pass Threshold	>20 mA (Range = 1 to 100 mA)
R-G Current Pass Threshold	>33 mA (Range = 1 to 100 mA)
Ground Ohms Pass Threshold	<25 Ω (Range = 0 to 99Ω)

Running a Loop Current & Ground Ohms Test

1. From the POTS Toolbox, select **Loop Cur. & Gnd Ω** , and press .
 - If the T-R DC Voltage measured was not Idle POTS as specified in DCV Setups, the CopperPro displays a message asking you whether or not to proceed, to avoid disruption of a possible non-POTS service.
 - If you select **Yes** to continue, and there is insufficient T-R voltage to yield a meaningful measurement, the CopperPro displays a **No T-R Voltage** message.
 - Otherwise, the CopperPro displays a result screen listing the three test results.
2. Press the desired function softkey to view continuous test results for any of the three tests.

Dial-Up Test Group

The Dial-Up Test group consists of terminated VF transmission tests that are conducted on idle working POTS lines. These tests operate by dialing various C.O. equipment, with the exception of the DID / DOD tests (*), which are used to test analog PBX trunk facilities. These PBX tests require an optionally-purchased software feature package, described in a separate Users Guide Addendum. The following is a list of test functions in this group:

- Milliwatt VF Loss Test
- Quiet Termination VF Noise Test
- Quiet Termination VF Long. Balance Test
- Number ANI Test
- On-Hook Caller ID Test
- Call Waiting Caller ID Test
- Monitor Line Function
- Smart-Pro Test Group
- SASS Test Group
- DATU Test Group
- DID PBX Emulation Test*
- DID CO Emulation Test*
- DOD PBX Emulation Test*
- DOD CO Emulation Test*

To access these tests, select **Dial-up Tests** in the POTS Toolbox, then press . The Dial-Up Test Toolbox is shown in Figure 4-30. The optional DID / DOD tests are shown as “grayed out” and inactive unless the feature package has been installed in the CopperPro.

Setting Up a Dial-Up Test

To set up a Dial-Up test, do the following:

1. Enter the setup parameters for all associated subtests shown in Table 4-13:

Table 4-13. Dial-Up Tests and Associated Subtests

Dial-Up Test	Associated Subtests
Milliwatt VF Loss (C.O. Tone sending device)	VF Loss test
Quiet Term. VF Noise (C.O. Quiet Termination)	VF Noise test
VF Long. Balance (C.O. Quiet Termination)	VF Long. Balance test
Number ANI (C.O. Smart-Pro / ANAC device)	None
On-Hook Caller ID (Test line with Caller ID feature)	None
Call Waiting Caller ID (Test line with Caller ID feature)	None
Monitor Line	None
Smart-Pro Test Group (C.O. Smart-Pro unit)	VF Loss, VF Noise, Caller ID tests
SASS Test Group (C.O. SASS unit)	VF Loss & VF Noise tests
DATU Test Group (C.O. DATU & Switch NTT)	Opens, Shorts & Grounds & other desired tests

2. Select the desired test in the Dial-Up Test Toolbox shown in Figure 4-30, and press . The **Select Dialing Mode** screen is displayed.
3. Press (**Setups**) to display the **Setups – Dial-up Tests** screen.
4. Select the desired Dialing parameters, listed in Table 4-14.
5. Press twice to return to the Dial-Up Test Toolbox.

Table 4-14. Dial-Up Test Setup Parameters

Setup Parameter	Setting (default in bold)
Dialing Mode	Tone or Pulse Dialing
Start Mode	Loop or Ground Start
Centrex Mode	Disabled or Enabled
Centrex Prefix Digit	None or user entry (ex.: <u>9</u>)
Feature Disable Prefix	None or user entry (ex.: * <u>82</u>)
Dialtone Detection	Enabled or Disabled
DTMF Duration (digit on / off times)	50 ms (Range = 50 to 250)

Running a Dial-Up Test

This section describes each Dial-up Test and shows you how to run it. Unless otherwise indicated, follow this procedure to run a test in this group:

1. Select **Dial-up Tests** in the POTS Toolbox, then press .
2. Select the desired Dial-Up test from the Dial-Up Toolbox, and press .
The **Select Dialing Mode** screen is displayed.

3. Do one of the following:

- Press **(Auto-Dial)**, select the desired phone number from the displayed **Phone Numbers** list, then press to start auto-dialing.

OR

- Press **(Manual Dial)** and manually dial the telephone number on the CopperPro keypad, then press .

4. In both the above cases, after dialing, the selected test is performed.



Milliwatt VF Loss	Quiet Term. VF Noise	VF Long. Balance	Number ANI
On-Hook Caller ID	Call Wtg. Caller ID	Monitor Line	Reserved
Smart Pro Tests	SASS Tests	DATU Tests	Reserved
DID PBX Emulation	DID C.O. Emulation	DOD PBX Emulation	DOD C.O. Emulation
Press ENTER to Start			
POTS 	XDSL 	TDR 	Setups

Figure 4-30. Dial-Up Test Toolbox

acy40s.eps

Running a Milliwatt VF Loss Test

1. After you have selected the Milliwatt function and either automatically or manually dialed a C.O. Milliwatt phone number as described earlier, the CopperPro waits for a fixed post-dialing interval, then automatically measures the Milliwatt frequency and VF line loss of the applied signal.
2. Once the test is completed, the CopperPro displays a screen similar to Figure 4-27 (VF Loss Results Screen, shown earlier in the chapter).
3. You can now press (**Contin. VF Loss**) to monitor signal loss in real-time.

To drop the switch connection and hang up, press from the VF Loss results screen, and the **Select Dialing Mode** screen is again displayed.

Running a Quiet Term. VF Noise Test

1. After you have selected the QT VF Noise function and either automatically or manually dialed a C.O. Quiet Termination phone number as described earlier, the CopperPro waits for a fixed post-dialing interval, then automatically measures the Metallic Noise (Nm) and Power Influence (PI) on the line.
2. Once the test is completed, the CopperPro displays a screen similar to Figure 4-24 (VF Noise Results Screen, shown earlier in the chapter).
3. You can now do the following:
 - Press (**Contin. Nm**) to monitor metallic noise in real-time.
 - Press (**Contin. P.I.**) to monitor Power Influence in real-time.
 - Press (**Power Harmonics**) to display a Power Harmonics graph.

To drop the switch connection and hang up, press from the VF Noise results screen, and the **Select Dialing Mode** screen is again displayed.

Running a VF Longitudinal Balance Test

1. After you have selected the VF Long. Balance function and either automatically or manually dialed a C.O. Quiet Termination phone number as described earlier, the CopperPro waits for a fixed post-dialing interval, then automatically measures the VF Longitudinal Balance of the line.
2. Once the test is completed, the CopperPro displays a screen similar to Figure 4-28 (VF Longitudinal Balance Results Screen, shown earlier).
3. You can now press (**Contin. VF Long. Bal.**) to monitor balance in real-time.

To drop the switch connection and hang up, press from the VF Long. Balance results screen, and the **Select Dialing Mode** screen is again displayed.

Running a Number ANI Test

The Number ANI (Automatic Number Identification) test allows you to capture and either display, or announce via speaker, the telephone number of the test line.

1. After you have selected the Number ANI function and either automatically or manually dialed a C.O. ANAC (Automatic Number Announcement Circuit) phone number as described earlier, the CopperPro begins monitoring the line for ANAC DTMF response digits.
2. Any valid digits received within 20 seconds from the completion of dialing are displayed by the CopperPro, and correspond to the telephone number of the line under test.
3. If the ANAC device is a voice-response-only unit, the tester's internal speaker is connected to allow you to hear the announced number.

The CopperPro is compatible with Voice-only, DTMF-only, and Voice / DTMF combination ANAC devices.

The switch connection is automatically dropped after a DTMF ANI number has been received, but *not* after the number announcement of a Voice-only ANAC device type. In this case, you must manually hang up by pressing .

Running an On-Hook Caller ID Test

The On-Hook Caller ID test enables the CopperPro to receive a call on the test line from another line, then capture and display Caller ID calling party information.

1. After you have selected the On-Hook Caller ID function and pressed , the CopperPro waits indefinitely (in an on-hook condition) for an incoming phone call, which must be placed from another POTS line to the POTS line under test.
2. If the test line is equipped with the Caller ID feature, the CopperPro detects the incoming Caller ID information (sent by the C.O. switch) after the first ringing interval. It then displays the received Phone number along with the associated Name, Date, and Message (if included).
3. Press (**Timing Details**) to view the following CID signal information:
 - Ringing Duration
 - Ringing to CD (Carrier Detection) Delay
 - CD to Seizure Delay
 - Seizure Duration
 - Seizure Bytes
 - Mark (frequency) Duration
 - Data Duration
 - Data Bytes
4. Press (**Raw Data**) to view the raw hexadecimal CID data digits.

If the test line was not equipped with the Caller ID feature, the CopperPro continues to wait until you press . If the CID data was garbled, the tester displays an error message after the first ringing interval.

Running a Call Waiting Caller ID Test

The Call Waiting Caller ID test enables the CopperPro to place a call on the test line to a Quiet Termination, wait to be called from another line, then capture and display Caller ID information sent on the line by the C.O. switch.

1. After you have selected the Call Waiting Caller ID function and either automatically or manually dialed a C.O. Quiet Termination (or other quiet line) as described earlier, the CopperPro waits indefinitely (in the off-hook condition) for an incoming call from another line.
2. If the test line is equipped with the Call Waiting Caller ID feature, the CopperPro detects the incoming Caller ID information (sent by the C.O. switch), and then displays the received Phone number along with the associated Name, Date, and Message (if included).
3. Press **[1]** (**Timing Details**) to view CID signal information, as above.
4. Press **[2]** (**Raw Data**) to view the raw hexadecimal CID data digits.

If the test line was not equipped with the Call Waiting Caller ID feature, the CopperPro continues to wait for incoming data. If the Caller ID data was garbled, the tester displays an error message.

To hang up, press **[BACK]** from the Caller ID results screen.

Running a Line Monitor Function

The Monitor Line function provides a high-impedance, non-intrusive method for monitoring the audio status of a spare or working POTS pair. It is not technically a Dial-Up test, but is most often used on working POTS lines, and is therefore included in this group.

1. After selecting **Monitor Line** in the POTS Toolbox, press **[ENTER]**.
2. The CopperPro internal speaker is connected to the test line at this point, with a “Monitor Enabled” message displayed on the screen.
3. To stop the Monitor function, press **[TEST STOP]** or **[BACK]**.

Smart-Pro Tests

The tests in this group enable the CopperPro to dial a C.O.-based Fluke Networks Smart-Pro unit and run various VF tests over a working POTS line.

The following procedure shows you how to dial a Smart-Pro and run a 10-Tone Slope test. Other Smart-Pro tests are performed in a similar manner.

To run a 10-Tone Slope test, do the following:

1. From the Dial-Up Test Toolbox, select **Smart-Pro Tests** and press .
2. The **Smart-Pro Menu** is displayed, with tests listed in Table 4-15:

Table 4-15. Smart-Pro Tests

Test	Description
N-Tone Slope	The Smart-Pro applies a sequential set of 3, 10, or 30 tones to the line. The CopperPro measures the Frequency, Loss, and Slope of these tones.
SmartTone Loss	The Smart-Pro applies a composite set of 100 VF tones to the line. The CopperPro measures and displays a VF Loss Graph.
Quiet Term. VF Noise	The Smart-Pro applies a quiet termination to the line for 20 seconds. The CopperPro measures Nm and P.I. on the pair.
Caller ID Callback	The Smart-Pro receives a command to return a call back to the test line. It then issues a 3 second audible tone to prompt you to hang up for the return call. Press <input type="button" value="ENTER"/> to hang up. The CopperPro then automatically captures and displays Caller ID information sent during the call.

3. Press (**N-Tone Slope**).

The **Select Dialing Mode** screen is displayed.

4. Select a method of dialing. Do one of the following:
- **Auto-Dial** - If you want the CopperPro to automatically dial the number of the C.O Smart-Pro, press (**Auto-Dial**). Select the telephone number from the displayed list, then press .
 - **Manual Dial** - If you want to manually dial the number of the C.O. Smart-Pro, press (**Manual Dial**). Dial the number from the CopperPro keypad, then press .
5. After the CopperPro successfully connects, the Smart-Pro announces the calling number and prompts you to enter the test code for the test you want to run.

Smart-Pro tests and their corresponding test codes are listed in Table 4-16:

Table 4-16. Smart-Pro Test Key Commands

To run this test:	Press key:
Milliwatt	1
Quiet Termination	2
3-Tone Sweep	3
10-Tone Sweep	4
30-Tone Sweep	5
SmartTone	6
Callback	7
Keypad	8

6. To start a 10-Tone Slope test, press **4** (for the 10-Tone Sweep), then .

The CopperPro measures the frequency, loss, and slope of each tone it receives and displays results in real time, as shown in Figure 4-31:

SP N-Tone Slope		Impedance = 600 Ω	
Tone #	Freq. - Hz.	Loss - dB	Slope - dB
1.	404	4.5	-1.5
2.	804	5.3	-0.7
3.	1004	6.0	0.0
4.	1205	6.7	0.8
5.	1405	7.6	1.6
6.	1603	8.6	2.6
7.	1804	9.6	3.7
8.	2004	10.7	4.8
9.	2801	15.4	9.5
10.	3003	16.6	10.7
VF Loss Graph	VF Slope Graph		

acy43s.eps

Figure 4-31. Smart-Pro N-Tone Slope Test Results

Failing slope and 1004 Hz loss values are identified in flashing reverse-video format.

7. Press (**VF Loss Graph**) or (**VF Slope Graph**) to view detailed graphs of the Loss and Slope, respectively.

SASS Tests

The SASS (Single Access Service System) tests enable the CopperPro to dial a C.O.-based Harris SASS unit for similar VF tests over a working POTS line.

To run tests in this group, follow the above procedure for “Smart-Pro Tests”. When prompted, enter the desired test code from Table 4-17.

Table 4-17. SASS Test Key Commands

To run this test:	Press key(s):
Milliwatt	86
Quiet Termination	85
3-Tone Sweep	83
10-Tone Sweep	80
Programmable Sweep	87
Callback	7
Keypad	5

DATU Tests

The DATU (Direct Access Test Unit) tests enable the CopperPro to dial a C.O.-based Harris DATU over a working POTS line. The DATU can then be instructed to access the line under test (through the switch Test Trunk), split off the battery feed circuit, and apply selectable terminations for an entered time period.

To run a DATU test, do the following:

1. From the Dial-Up Test Toolbox, select **DATU Tests** and press .

The **DATU** test selection screen is displayed.

2. Do one of the following:

- Press (**Automatic Open**), then, follow the on-screen prompts and instructions.

This test allows the DATU Auto-Open or “dry line” number (typically a unique number that is separate and distinct from the normal DATU access number) to be dialed from the test line. After the number is dialed, the battery feed circuit is split from the line for one to two minutes (with no termination applied).

Note

To verify access and splitting, run the Continuous DCV test until you see that the T-R battery voltage has been removed. Next, run a POTS Auto-Test on the test line to quickly give you the most information before battery voltage is restored, following the timeout.

OR

- Press (**Manual Termination**), then, follow the on-screen prompts and instructions.

This test allows the DATU’s normal access number to be dialed, after which you can instruct it to apply a specific metallic termination to the test line for the entered time period.

During the test, supply the following as prompted by the DATU:

- Password (if required)
- Phone number of the line under test
- Termination code (see table below)
- Number of minutes (**Hold Time**) to apply the termination.

Table 4-18 lists the terminations that the DATU can apply:

Table 4-18. DATU Manual Termination Codes

To run this test:	Press key(s):
Open Line	6
Short Line	7
Short & Ground Line	33
Ground Ring	37
Ground Tip	38
Hi-Level TR Tone	44
Hi-Level RG Tone	47
Hi-Level TG Tone	48

3. When prompted to hang up, press \bigcirc then .

The CopperPro goes on-hook, and you return to the **Main** menu.

4. Wait 30 seconds to allow the DATU to remove battery and apply the termination. Then, run the appropriate tests for the selected termination.

Note

*Be sure to complete all testing within the **Hold Time** period, or the CopperPro could report erroneous measurement results.*

Terminated VF Tests

Terminated VF Tests are a group of double-ended, voice frequency Auto-Tests that require a far-end terminating device such as the Fluke Networks TN2x00 “Terminator” or “SmartStrap”; 3M “FED” or “FEDII”; or CMC “My Helper”. The CopperPro automatically controls the Terminator, FED and Helper over the same pair, thus not requiring a separate control pair. The SmartStrap requires a separate control pair.

During the Auto-Tests, the CopperPro first runs a sequence of single-ended parametric tests. It then conducts a series of terminated VF transmission tests to effectively qualify the pair for voice frequency POTS service. The following individual tests are conducted:

- AC & DC Voltage
- Shorts & Grounds
- Opens
- Load Coils
- VF Noise
- VF Longitudinal Balance
- Tip, Ring, Loop and Ground Resistance
- Resistive Unbalance
- 10-Tone Slope (SmartStrap, FED, FEDII, and Helper)
- SmartTone Loss & Slope (TN2100 Terminator)

Setting Up a Terminated VF Test

To set up a test, complete the following:

1. Set the Pass thresholds for each individual test (see previous list).
2. Set up the Auto-Test. Do the following:

- a) From the POTS Toolbox, select **Terminated VF Tests** and press .
- b) From the **Select Terminated Test Type** screen, press (**Setups**).
- c) Enter a setting for Loop Resistance, Ground Resistance, and Unbalance Resistance Pass Thresholds.

Running a Terminated VF Test

This procedure shows you how to run a **Terminator VF Auto-Test**. You can use this procedure to run any of the tests in this group.

To run a Terminated VF Test, do the following:

- 1. From **Select Terminated Test Type**, press (**Terminator VF Auto-Test**).

The Terminator VF Auto-Test connection diagram is displayed as shown in Figure 4-32:

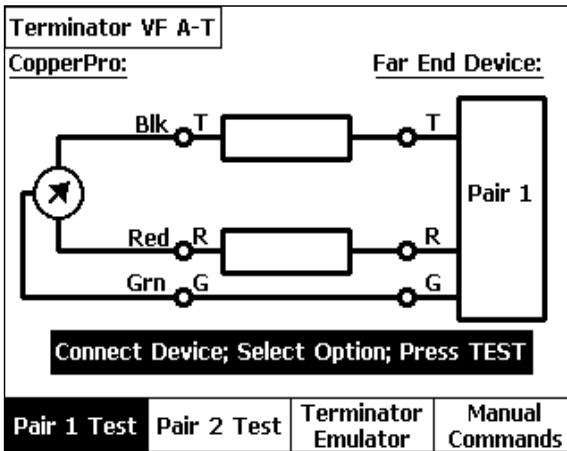

acy107s.eps

Figure 4-32. Terminator VF Auto-Test Selection Screen

2. Connect the CopperPro and Terminator (Far End Device) as shown in the connection diagram, connecting both units to either one or two test pairs.
3. Select either (Pair 1 Test) or (Pair 2 Test), then press .
4. The CopperPro displays the test it is currently running, and when completed, displays a Summary Result screen like that of Figure 4-33:

Terminator VF A-T		Failed Resist. Unbal.	
AC/DC Voltage		: Pass	
Shorts & Grounds		: Pass	
Opens		: Pass	
Load Coils		: No	
Metallic Noise		: Pass	
Power Influence		: Pass	
Long. Balance		: Pass	
Loop Resistance Test		: Fail	
VF Loss/Slope		: Pass	
Details		Save Results	

acy100s.eps

Figure 4-33. Terminator VF Auto-Test Summary Results

The first failed test is highlighted by the cursor (**Loop Resistance** in this case), with a failure description in the upper right corner of the screen (**Failed Resist. Unbal.**).

5. To view detailed results for a test, follow the procedure listed earlier in this chapter under the POTS Auto-Test section. Detailed results for the VF Loss / Slope test are shown in Figure 4-34:

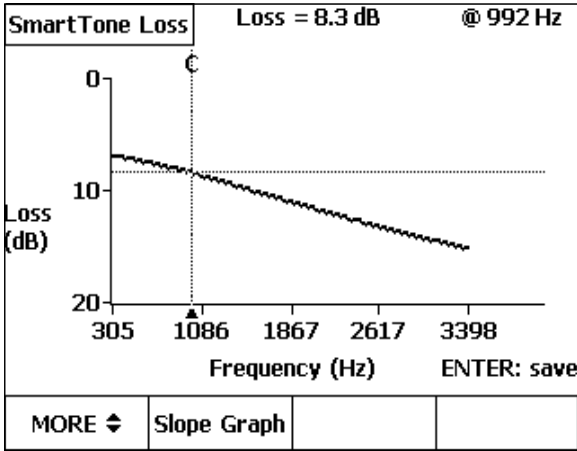

acy103s.eps

Figure 4-34. Terminator VF Auto-Test Results: SmartTone Loss

6. Press (**Slope Graph**) to view the VF Loss results in terms of Slope.
7. Press to return to the Summary Results screen.

Saving Terminator VF Auto-Test Results

As indicated earlier in the chapter, Auto-Test results are *not* automatically saved. Follow the same instructions under “Saving POTS Auto-Test Results” to save the Terminator Auto-Test results.

Using the CopperPro as a Terminator

In the absence of a TN2000 or TN2100 Terminator, you can use another CopperPro as a substitute by placing it in the “Terminator Emulator” mode. To do this, perform the following:

1. From the Terminator VF Auto-Test Selection screen (Figure 4-32), press  (**Terminator Emulator**).



The CopperPro Terminator Emulator screen is displayed. In this mode, the CopperPro is monitoring Pair 1 for DTMF commands from the testing CopperPro at the far end, in order to run a terminated Auto-Test.

Terminator Emulator activity states are as follows:

- **Idle** – If the Emulator is neither receiving commands from a CopperPro nor applying a requested termination, it displays an **Idle** message on its screen.
- **Test in Progress** – If the Emulator is either receiving commands from a CopperPro or is applying a requested termination, it displays a **Test in Progress** message.

Note

In the Terminator Emulator mode, the CopperPro places a certain impedance on the test pair due to its DTMF receiver circuit. This impedance is approximately 100 Ohms of resistance from Tip to Ring, and can be used to verify that the Emulator is connected prior to running a terminated Auto-Test. During the Auto-Test, this impedance is automatically removed to keep test results from being adversely affected.

2. To exit the Terminator Emulator mode, press  or .

Manually Controlling a Far-End Terminator

It may often be necessary to manually control a Terminator (or Terminator Emulator) from the testing CopperPro to run *individual* tests on the pair, rather than an *Auto-Test*, for more detailed fault analysis.

To control the Terminator via manual commands, do the following:

1. From the Terminator VF Auto-Test Selection screen (Figure 4-32), press  (**Manual Commands**).

The **Manual Term. Commands** screen is displayed.

2. Select the desired **Terminator Function** (refer to the list in Table 4-19), and the time **Duration** that the function will be applied, and press .

The CopperPro signals the Terminator to apply the selected termination for the selected time, and then displays a **Termination Applied** message.

3. Press , and run the appropriate CopperPro tests for the selected termination or tone.

Table 4-19. Manual Terminator Commands

To apply this termination:	Select this Function:
Short	Ring-Tip Short
Ring Ground	Ring Ground
Tip Ground	Tip Ground
Short & Ground	Tip & Ring Ground
VF Quiet Termination	Quiet Term.
Open Line	Open Circuit
Voiceband Tone	VF Single Tone <ul style="list-style-type: none"> • Frequency (24 Hz to 20 kHz) • Impedance (600Ω or 900Ω)
Wideband Tone	WB Single Tone <ul style="list-style-type: none"> • Frequency (10 to 1200 kHz) • Impedance (100Ω or 135Ω)
SmartTone (100-Tone sig.)	SmartTone

Chapter 5

XDSL Testing and Loop Qualification

Introduction

The tests described in this chapter can help you determine a cable pair's ability to carry modern high-speed digital services.

The chapter begins by showing you how to set up and run a DSL Auto-Test. Like the POTS Auto-Test, the DSL Auto-Test contains a series of individual tests. However, the DSL Auto-Test is a double-ended test, requiring a far-end terminating device. As a general practice, you can use this Auto-Test to obtain a quick overall assessment of the transmission capabilities of a cable and its suitability for various grades of service. You are then instructed on how to run an ADSL Verify Test, which provides an indication of the ability to successfully turn up an ADSL line, as well as troubleshooting help on problem lines.

The second half of this chapter focuses on the individual tests in the XDSL Toolbox. This toolbox contains both single-ended physical parametric tests and double-ended wideband transmission tests. As a group, the tests in the XDSL Toolbox are useful for identifying the presence of line trouble that can disqualify a pair from carrying a particular digital service. Additionally, the tests can help you determine the maximum service data rate that a pair is capable of carrying.

DSL Auto-Test

The DSL Auto-Test is a pre-programmed test sequence that requires a Fluke Networks TN 2x00 “Terminator”, or another CopperPro operating in the “Terminator Emulator” mode, as the far-end terminating device. The CopperPro automatically controls the Terminator or Terminator Emulator over the test pair.

During the DSL Auto-Test the CopperPro first runs a sequence of single-ended parametric tests, followed by an optional terminated VF Loss test, then a series of terminated wideband transmission tests. These test results are used to effectively qualify the pair for either a specific, user-selected digital service, or a series of digital services in one pass. The following individual tests are conducted:

- AC & DC Voltage
- Shorts & Grounds
- Opens
- Load Coils
- VF Metallic Noise & Power Influence (optional)
- VF Longitudinal Balance (optional)
- Single-tone VF Loss, or SmartTone Loss / Slope* (optional)
- Tip, Ring, Loop, & Ground Resistance
- Resistive Unbalance
- Wideband Noise / Level
- Nyquist Single-Frequency Loss, or Composite-Tone Loss*
- Wideband Longitudinal Balance*

* Requires TN2100 Enhanced Terminator.

Setting Up a DSL Auto-Test

In this test, pairs are qualified based on Pass Thresholds that are automatically selected for the Service Type chosen. To choose a Service Type, do the following:

1. From the **Main** menu, select **DSL Auto-Test**, then, press ENTER.

The **DSL Auto-Test Selection Screen** is displayed, shown in Figure 5-1.

2. Press 4(**Setups**).

The first DSL Auto-Test **Setups** screen is displayed, shown in Figure 5-2, with the cursor positioned on the **Service Qualified** field.

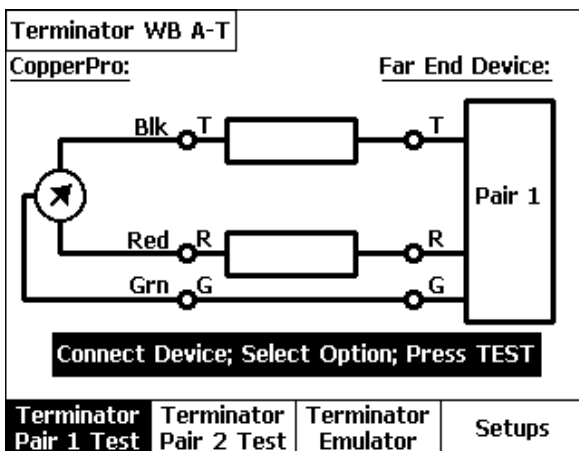

acy53s.eps

Figure 5-1. DSL Auto-Test Selection Screen

Setups - QSL Thresholds			
Service Qualified	:	HDSL2	
Loss Pass/Fail Thresh.	:	<u>Predefined</u>	
Cable Type	:	<u>Air Core</u>	
Cable Gauge	:	<u>24 AWG</u>	
Cable Temperature (F)	:	<u>68</u> °F	
Edit		More	Restore Defaults

acy54s.eps

Figure 5-2. DSL Auto-Test Setups: Screen 1

3. Press **[F1]** (**Edit**) and use **↓** or **↑** to select the desired Service Type to be qualified, then press **[ENTER]**. Refer to Table 5-1 for supported Service Types and their Qualification Criteria.

Table 5-1. Service Types for Qualification

Service Type	Qualification Criteria
DDS 56 kb/s	<ul style="list-style-type: none"> • Param. results vs. DDS 56 Pass Thresholds • 28 kHz (Nyquist) Loss & WB Long. Balance
DDS 64 kb/s	<ul style="list-style-type: none"> • Param. results vs. DDS 64 Pass Thresholds • 32 kHz (Nyquist) Loss & WB Long. Balance
ISDN Basic Rate	<ul style="list-style-type: none"> • Param. results vs. ISDN-B Pass Thresholds • 40 kHz (Nyquist) Loss & WB Long. Balance
DDS Ext. Reach	<ul style="list-style-type: none"> • Param. results vs. DDS ER Pass Thresh. • 82 kHz (Nyquist) Loss & WB Long. Balance

Table 5-1. Service Types for Qualification (continued)

Service Type	Qualification Criteria
ADSL (DMT)	<ul style="list-style-type: none"> • Param. results vs. ADSL Pass Thresholds • Up. & Downstream Estimated Data Rates • 138 kHz WB Long. Balance
HDSL	<ul style="list-style-type: none"> • Param. results vs. HDSL Pass Thresholds • 196 kHz (Nyquist) Loss & WB Long. Bal.
HDSL2	<ul style="list-style-type: none"> • Param. results vs. HDSL2 Pass Thresholds • Up. & Downstream Loop Attenuation • 196 kHz WB Long. Balance
HDSL4	<ul style="list-style-type: none"> • Param. results vs. HDSL4 Pass Thresholds • Up. & Downstream Loop Attenuation • 196 kHz WB Long. Balance
T1	<ul style="list-style-type: none"> • Param. results vs. T1 Pass Thresholds • 772 kHz (Nyquist) Loss & WB Long. Bal.
Custom	<ul style="list-style-type: none"> • Param. results vs. User-entered Thresholds • Loss & WB Long. Balance @ User-entered Frequency (Nyquist)
All (default)	<ul style="list-style-type: none"> • Param. results vs. Tightest Pass Thresholds of all above Services • Loss & WB Long. Balance @ Nyquist Frequencies of all above Services

4. From Setup Screen 1, select the **Loss Pass / Fail Thresholds** field.
Choose one of the following options:
 - a) **Predefined** Thresholds (default) – These Pass / Fail thresholds are factory-predefined for the Service Type chosen, with unique values for each test.

OR
 - b) **Custom** Thresholds – This selection uses existing Pass / Fail thresholds that you have entered in the Setups menu for each of the individual tests in the sequence, allowing the qualification of a new or different Service Type.
5. From Setup Screen 1, enter appropriate selections for **Cable Type, Cable Gauge,** and **Cable Temperature.**
6. Press (**More**) to view subsequent Setup screens:
 - a) If you chose **Predefined** thresholds in step 4 above, the only remaining Setup screen is the VF Test Selection screen, which enables you to either include (**Y**) or exclude (**N**) the following tests:
 - **VF Noise** (Metallic Noise & Power Influence)
 - **VF Loss** (Single Tone, TN2000; SmartTone, TN2100)
 - **VF Long. Balance**
 - b) If you chose **Custom** thresholds in step 4, a third Setup screen is displayed (in addition to the above VF Selection screen), enabling you to enter Pass thresholds for one of the following parameters, depending on which Service Type you selected:
 - Nyquist frequency Loss value for the chosen Service Type.
 - All Nyquist frequency Loss values for Service Type = **All**.
 - Nyquist frequency **and** Loss values for Service Type = **Custom**.
 - Up. & Down. Loop Attenuation values for **HDSL2 & HDSL4**.
7. Press to return to the DSL Auto-Test Selection Screen.

Running a DSL Auto-Test

After selecting the desired Setup options, do the following:

1. Connect the CopperPro and Terminator or Terminator Emulator (**Far End Device**) as shown in Figure 5-1. (See Chapter 4, “Using the CopperPro as a Terminator”). Connect both devices to either one or two test pairs.
2. Select either (Pair 1 Test) or (Pair 2 Test), then press .
3. The CopperPro displays on-screen the test it is currently running. Prior to the last test (Wideband Long. Balance), *disconnect the CopperPro green Ground lead* when prompted by the audible tone and screen message, to ensure accurate WB Longitudinal Balance results.

Note

Be sure to reconnect the Ground lead when the test is completed.

4. When testing is completed, a Summary Results screen is displayed like that in Figure 5-3 for the **HDSL2** Service Type, using a TN2100:

Terminator WB A-T	Failed Loop Atten.
AC/DC Voltage	: Pass
Shorts & Grounds	: Pass
Opens	: Pass
Load Coils	: No
Metallic Noise	: Pass
Power Influence	: Pass
VF Loss/Slope	: Pass
VF Long. Balance	: Pass
WB Noise / Level	: Pass
Loop Resistance Test	: Pass
WB Loss	: Fail
WB Long. Bal.	: Pass
Details	Save Results

acy55s.eps

Figure 5-3. DSL Auto-Test Summary Results: HDSL2

Note that the pair failed the **WB Loss** test, with a descriptive message in the upper right corner of the screen (**Failed Loop Atten.**).

- 5. Select the desired test and press (**Details**) to view detailed test results. Detailed results for the failed WB Loss test are shown in Figure 5-4.

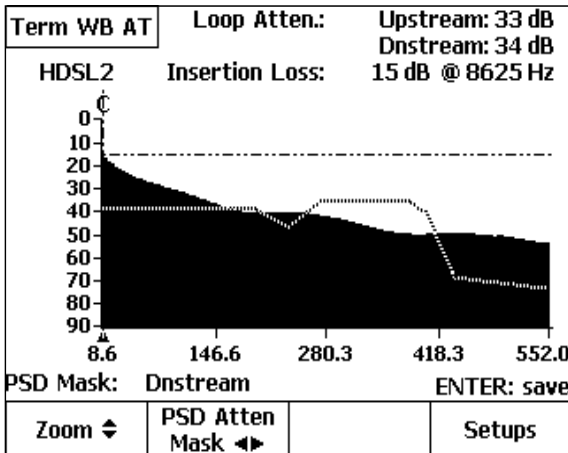

acy56s.eps

Figure 5-4. DSL Auto-Test Loss Results: HDSL2 Loop Attenuation

The **HDSL2** Loss test (using **Predefined** thresholds) runs a comprehensive multi-frequency Loop Attenuation test on the pair. It does this, rather than making the traditional single-frequency Nyquist Loss measurement, in order to more effectively qualify the pair *specifically* for HDSL2 service. The same approach is used for **HDSL4** service qualification.

The Loop Attenuation values displayed in the upper right corner represent an average value of the pair’s loss across the Upstream and Downstream frequency bands. In this example, both the Upstream and Downstream Loop Attenuation values are greater than the Pass thresholds, and are displayed in flashing reverse-video format.

6. To superimpose a transmitted Power Spectral Density (PSD) mask on the Loop Attenuation graph, press (PSD Atten Mask), then press or to overlay either the Upstream or Downstream mask on the graph.

Figure 5-4 shows the Loop Attenuation graph with the superimposed Downstream PSD mask.

- The graph itself shows the pair's attenuation across the frequency bands utilized by the HTU-C (Downstream) and HTU-R (Upstream) equipment.
 - The PSD masks show the relative signal power transmitted across the bands by the HTU-C (Downstream) and HTU-R (Upstream) equipment.
 - From visually observing the graph and superimposed mask, it can be seen that the more *dark area* under the mask curve, the *more likely* the pair will be able to carry HDSL2 service due to the lower loss across the band of interest. Conversely, the more *light area* under the mask curve (as in the above example, from 270 to 420 kHz), the *less likely* the pair will be able to reliably carry HDSL2 traffic. This is confirmed by the failure of this test.
7. Press to save the waveform in the **Frequency Graph** storage memory.

DSL Auto-Test Results: ADSL Service Type

The ADSL Loss test (using **Predefined** thresholds) also runs a comprehensive multi-frequency sweep on the pair. It does this rather than making traditional single-frequency Nyquist Loss measurements at the Upstream (138 kHz) and Downstream (1100 kHz) frequencies, in order to more accurately estimate the achievable Upstream and Downstream data rates on the pair. The process is as follows:

1. Loss values at each DMT frequency (tone) bin, along with Wideband Noise measurement data for each bin, enable the CopperPro to generate a Signal-to-Noise Ratio (SNR) graph as shown in Figure 5-5.

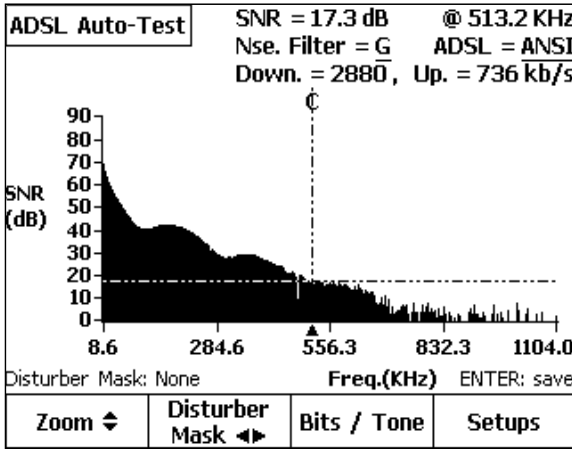

acy57s.eps

Figure 5-5. DSL Auto-Test Loss Results: ADSL SNR Graph

2. From the SNR values, the CopperPro generates a **Bits / Tone** graph (Figure 5-6), showing the number of data bits able to be encoded at each bin. Estimated Upstream and Downstream data rates (shown in the upper right corner of Figures 5-5 and 5-6) are generated from the aggregate of encoded data bits across both of the bands.
3. Press to save any of the above waveforms in the **Frequency Graph** storage memory.

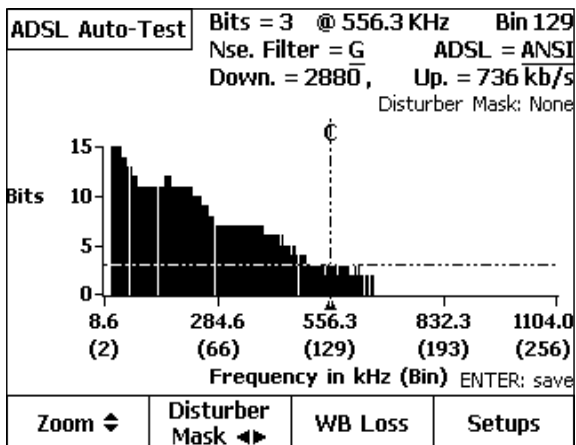

acy58s.eps

Figure 5-6. DSL Auto-Test Loss Results: ADSL Bits / Tone Graph

Disturber Mask Overlays

From any one of the ADSL **Loss**, **SNR**, or **Bits / Tone** graph screens, press 2 (**Disturber Mask**), then press \rightarrow or \leftarrow to superimpose any of a group of typical disturber masks on the graphs. By comparing the graphs to each type of disturber mask, you can visually determine which type of service on a pair in the same or adjacent binder group may be affecting the pair under test.

DSL Auto-Test Results: ALL Service Types

To run a rapid qualification summary of *all* Service Types (listed in Table 5-1) in a single pass, select **All** for the **Qualified Service** in the Setup screen in Figure 5-2. Figure 5-7 shows the detailed Loss results for a typical pair.

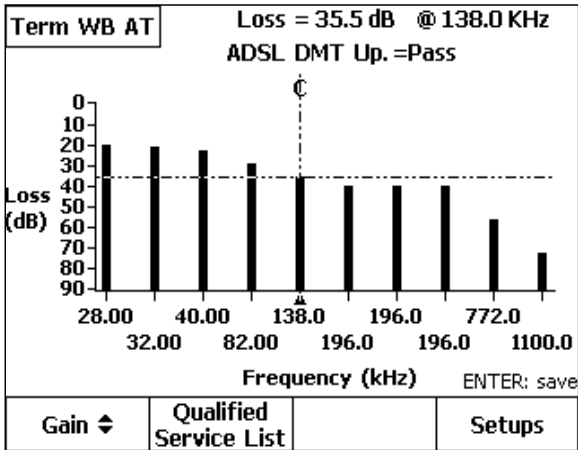

acy59s.eps

Figure 5-7. DSL Auto-Test Loss Results: ALL Service Types

To rapidly qualify all service types in a single pass, the CopperPro measures the Nyquist frequency loss of each Service Type, along with other parameters. Each vertical bar in the above figure corresponds to the Nyquist (maximum energy) frequency of a given Service Type. HDSL, HDSL2, and HDSL4 services are all qualified in this test at the same frequency (196 kHz), but have separate Pass thresholds.

Press (Qualified Service List) to view a list of all Service Types and their qualification status, based on Loss results. Figure 5-8 shows a typical QSL.

Qualified Service List		
• DDS 56 kb/s Service	28 kHz	Pass
• DDS 64 kb/s Service	32 kHz	Pass
• ISDN BR (U Intfc.) Service	40 kHz	Pass
• Ext. Reach DDS Service	82 kHz	Pass
• ADSL DMT Upstream	138 kHz	Pass
• HDSL (2 Pair T1) Service	196 kHz	Fail
• HDSL2 (1 Pair T1) Service	196 kHz	Fail
• HDSL4 (2 Pair T1) Service	196 kHz	Fail
• T1 Service	772 kHz	Fail
• ADSL DMT Downstream	1100 kHz	Pass
		Setups

acy60s.eps

Figure 5-8. DSL Auto-Test Loss Results: Qualified Service List

Saving DSL Auto-Test Results

Auto-Test results are *not* automatically saved. To save them, do the following:

1. From the Summary Result screen, press (**Save Results**).
2. Enter the following Test Identification information:
 - **Job #:** Enter up to 16 alphanumeric characters.
 - **Ckt. ID:** Enter up to 16 alphanumeric characters.
 - **Cable:** Enter up to 16 alphanumeric characters.
 - **Pair:** Enter up to 16 alphanumeric characters.
 - **Side:** Select Side **1** or **2** (for 2 pair services such as HDSL4).
 - **Segment:** Select Segment **A – F** (for repeaters or doublers).
3. Press (**Save Results**). The test results are now saved in Text Results memory, along with the qualified service Type and Test ID data.

ADSL Verify Test

The ADSL Verify Test is a single-ended test of an active ADSL line to determine the presence of both the C.O. DSLAM and customer modem, and to determine the approximate bit-rate capability of the line. It is comprised of a test looking toward the C.O. DSLAM (**ATU-C Test**) with the customer modem disconnected, and a test looking toward the customer modem (**ATU-R Test**) with the DSLAM disconnected.

This test may either be performed at installation of the DSLAM or modem to verify service turn-up, or as a diagnostic tool to help pinpoint the root problem during ADSL trouble calls on existing services.

The ATU-C test should be run at the customer's location in order to get meaningful bit-rate information over the entire loop. The ATU-R test can be performed at either the DSLAM or customer's location, as it is used only to verify operation of the modem and not to obtain bit-rate information.

Setting up an ADSL Verify Test

There are no setups required for this test. The test is not modem-vendor specific and works equally well on all network equipment conforming to ANSI T1.413.

Running an ADSL Verify Test

From the tester **Main** menu (Figure. 3-2), select **ADSL Verify Test** and press . The ATU-C Test / ATU-R Test option screen is displayed.

ATU-C Test

To test the line and DSLAM for performance, do the following:

1. At the customer's location, disconnect the outside line from the ADSL modem.
2. Connect the tester pair 1 test leads to the Tip, Ring, and Ground terminals of the outside line.
3. Press (**ATU-C Test**), then press .

ATU-C Test Results

At the completion of the ATU-C DSLAM test, one of three basic screens is displayed:

- **Data Activity Detected**

This result indicates that the modem is still connected to the line, and needs to be disconnected; or that the modem has just been disconnected, and you should wait about a minute before repeating the test.

- **DSLAM Detected**

After successful training with the DSLAM, the tester displays predicted Downstream and Upstream bit-rate ranges and the measured signal loss at the training frequency.

Downstream Bit-rate Ranges:

HIGH = 4 to 8 Mb/s

MED = 2 to 4 Mb/s

LOW = 1 to 2 Mb/s

Upstream Bit-rate Ranges:

HIGH = 0.5 to 1 Mb/s

LOW = 0.1 to 0.5 Mb/s

- **DSLAM Not Detected**

This indicates that the DSLAM has not yet been connected at the frame, the DSLAM modem is not operational, or the outside line will not support ADSL operation. This could be due to the presence of one or more load coils; excessive loop length, bridged tap length or background noise; poor splice joint; resistance fault; or interference from adjacent digital circuits or AM radio signals.

ATU-R Test

To test for the presence of a customer's ADSL modem, do the following:

1. Connect the tester pair 1 leads to the modem "Line" jack, or to the outside line, with the DSLAM disconnected.
2. Press (**ATU-R Test**), then press .

ATU-R Test Results

At the completion of the ATU-R test, one of three screens similar to the ATU-C screens (listed above) is displayed. The "ADSL Modem Detected" screen gives the signal loss at the modem training frequency but does not give predicted data rates as in the ATU-C test.



The XDSL Toolbox

The XDSL toolbox (shown in Figure 5-9) is like the POTS Toolbox in that it contains both parametric and transmission tests. The parametric tests are exactly the same as in the POTS Toolbox, and are available for ease of use.

- Voltage
- Shorts & Grounds
- Opens
- RFL
- Load Coils
- Leakage Stress
- Loop Devices
- Tracing Tone

The transmission tests, however, are designed to test pairs for wideband (WB) transmission characteristics rather than voiceband. The ADSL Verify Test is the same as that on the Main menu, and has been described earlier. The following transmission tests are described in detail in this chapter:

- WB Noise / Level
- WB Loss
- WB Long. Balance
- Send WB Tone
- ADSL Auto-Test
- Terminated WB Auto-Tests
- Impulse Noise

Voltage	Shorts & Grounds	Opens	R.F.L.
Load Coils	Leakage Stress	Loop Devices	Tracing Tone
WB Noise / Level	WB Loss	WB Long. Balance	Send WB Tone
ADSL Auto Test	ADSL Verify Test	Terminated WB Tests	Impulse Noise
<p>(Measure AC & DC Voltage)</p> <p>Press TEST to Start</p>			
POTS 	XDSL 	TDR 	Setups

acy61s.eps

Figure 5-9.XDSL Toolbox

Starting and Stopping a Test in the XDSL Toolbox

Unless otherwise noted in the section for a particular test, use one of the following procedures to run a test in the XDSL toolbox:

- From the **Main** menu, press (**XDSL**). Select the test you want to run, then press .

OR

- From the setup menu for a particular XDSL test, press .

To stop a running test, press or .

WB Noise/Level Test

The WB Noise / Level test measures metallic noise or signal level present on a pair. The test provides a snapshot wideband measurement on either spare pairs (in the Terminated mode) or on active pairs (in the Bridged mode).

The test employs DSP techniques to perform measurements at multiple frequencies at the same time. Depending on the choices you make in the test Setups, the CopperPro takes measurements with either the higher resolution Nyquist frequency set (**Fine**) or with the ADSL DMT frequency set (**Coarse**). The “Fine” (Nyquist) frequency set enables measurements at more than 2000 frequency points across the band, which results in very fine resolution for tests on spare pairs. The “Coarse” (DMT) frequency set enables measurements at the standard 256 ADSL DMT bin frequencies, which can be helpful when you monitor active ADSL lines. The Fine Mode may also be used on ADSL lines, allowing energy outside the DMT bins to be visualized (such as disturber or AM radio interference).

Setting Up a WB Noise/Level Test

To set up a WB Noise / Level test, follow the instructions under “Displaying a Setup Menu” in Chapter 3. Refer to Table 5-2 for Setup parameters for the test.

Table 5-2. WB Noise/Level Test Setup Parameters

Parameter	Setting (default in bold)
Termination Mode	Terminated or Bridged
Measurement Filter	G (ADSL) , None, E (ISDN BR), F (HDSL)
Measurement Mode	Fine (Nyquist) or Coarse (DMT)
Noise Pass Threshold	≤ -50 dBm (Range = 0 to -99)
WB Weighted Noise Pass Threshold	≤ 55 dBm (Range = 0 to 99)

WB Noise/Level Test Results for a Spare Pair

To run a WB Noise / Level test on a spare pair, select **WB Noise / Level** on the XDSL Toolbox, and press .

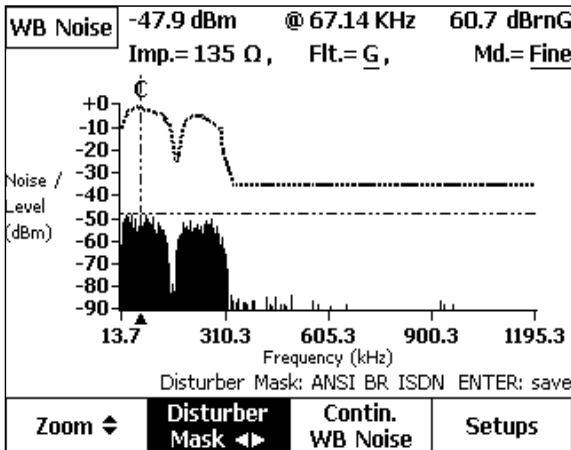

The graph in Figure 5-10 shows the results of a WB Noise / Level test that was run on a spare pair having crosstalk from an adjacent ISDN Basic Rate circuit.



acy62s.eps

Figure 5-10. WB Noise / Level Test Results: ISDN Crosstalk

The noise level and frequency at the cursor position are displayed at the top of the screen (**-47.9 dBm @ 67.14 kHz**). The aggregate “Weighted Noise” across the filter band is shown in the upper right corner of the screen (**60.7 dBBrnG**).

To zoom in or out horizontally, press  (**Zoom**), then press  to zoom in or  to zoom out.

You can select any of eight Disturber Masks to overlay the noise graph, shown as dotted lines above the noise waveform. By comparing the disturber mask and the noise waveform, you can more easily identify the type of crosstalk interference. If the shape of a particular mask matches that of the noise waveform, the disturber is the same type as the mask label (as in Figure 5-10, where the noise pattern exactly matches the ISDN BR crosstalk pattern).

To select a mask to overlay, press **[2]**(**Disturber Mask**), then, repeatedly press **[←]** or **[→]** until a matching mask is displayed.

To view a continuous noise measurement *at a selected frequency*, move the cursor to the desired frequency, and press **[3]**(**Contin. WB Noise**). The signal level at the selected frequency is continuously displayed in large numerals, along with a peak-detecting bar graph.

To save the displayed waveform in the Frequency Graph memory, press **[ENTER]**.

WB Noise/Level Test Results for a Working ADSL Pair

Figure 5-11 shows results from a WB Noise / Level test on an active ADSL line, in the **Bridged** termination mode.

Results obtained from running a bridged WB Noise / Level test on a working ADSL circuit can help you determine why the circuit is not performing “up to speed”, when other line characteristics indicate that it should be. This non-intrusive test can often be used to diagnose excessive bridged tap, interference from other data circuits or AM radio signals, or defective modems as the cause of a performance problem.

The **[1]**(**Zoom**) and **[2]**(**Disturber Mask**) keys operate as described earlier.

To continuously monitor any one of the DMT bin signals, move the cursor to the desired frequency, then press **[3]**(**Contin. WB Level**). Instantaneous variations in frequency bins can be caused by impulse noise. If such variations are observed, you can measure them by running an Impulse Noise test (see “Impulse Noise Test” for details).

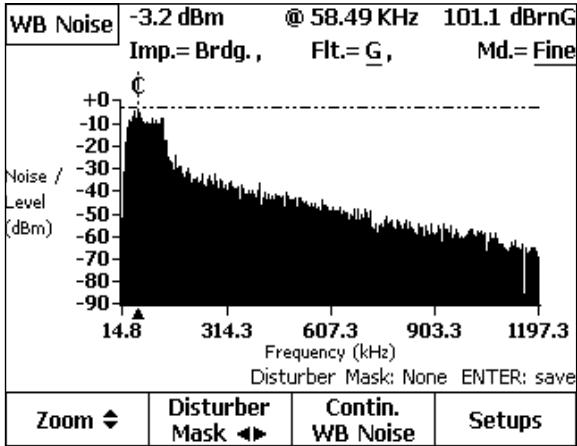

acy63s.eps

Figure 5-11. WB Noise / Level Test Results: Working ADSL Line

WB Loss Test

The WB Loss test measures the level and frequency of a transmitted signal in the 10 kHz to 1200 kHz spectrum. The test requires a generic transmitter at the far end of the pair, such as another CopperPro, TN2100 “Terminator”, or C9925BLT. The far-end device must be instructed to transmit the desired frequency at a level of 0 dBm, 135 Ohm impedance.

Note

For measurement accuracy, the sending device’s frequency should be as close as possible to an integral multiple of 508.626 Hz. This enables the CopperPro to use the high-resolution Nyquist (Fine) frequency bin spacing so that the greatest number of possible measurement frequencies is covered. If the sending device is a CopperPro or Terminator, it automatically rounds off the entered frequency to the nearest bin frequency to ensure accurate results.

Unlike the DSL Auto-Test, the WB Loss test is manually controlled. There is no communication between the two units.

Setting Up a WB Loss Test

The WB Loss test has no test-specific setups.

Running a WB Loss Test

To run a WB Loss test, do the following:

1. From the XDSL toolbox, select **WB Loss** and press .
The **WB Loss** connection diagram is displayed.
2. Connect the CopperPro and Sending Unit to the test pair as shown, and press .
3. The CopperPro measures all signals in the 10 kHz to 1200 kHz spectrum, and positions the cursor on the largest signal as shown in Figure 5-12.

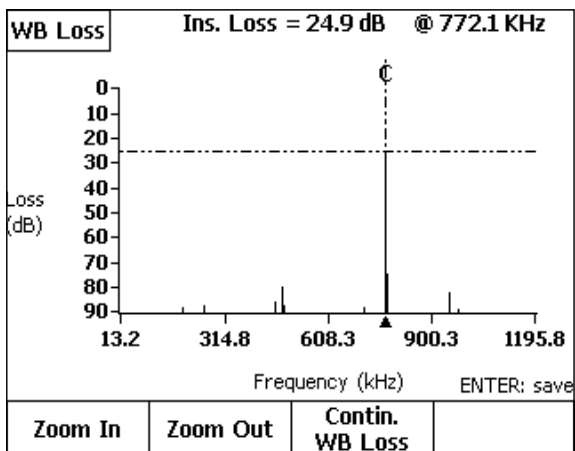

acy64s.eps

Figure 5-12. WB Loss Test Result Screen

In the above test, the transmitted signal was 772 kHz (the T1 Nyquist frequency) in order to qualify the test pair for T1 service. The result at the top of the screen indicates the pair's insertion loss at the displayed frequency.

4. Press **[1]** (**Zoom In**) once or twice to expand the horizontal scale for easier viewing of adjacent frequency components, and **[2]** (**Zoom Out**) to compress the scale back again.
5. Press **[3]** (**Contin. WB Loss**) to monitor the signal at the selected frequency in real-time.
6. Press **[ENTER]** to save the waveform in the Frequency Graph storage memory.

WB Longitudinal Balance Test

The WB Longitudinal Balance test measures the metallic (T-R) effect of applying a common-mode disturbing signal on the pair. This effect is directly related to the pair's balance to Ground. The test requires a far-end CopperPro or TN2100 "Terminator" to apply the disturbing tone, which is automatically controlled over the same pair by the tester.

Setting Up a WB Longitudinal Balance Test

To set up a WB Longitudinal Balance test, follow the instructions under "Displaying a Setup Menu" in Chapter 3. Refer to Table 5-3 for setups.

Table 5-3. Longitudinal Balance Test Setup Parameters

Parameter	Setting (default in bold)
Termination Impedance	100Ω or 135Ω
Measurement Filter	G (ADSL) , None, E (ISDN BR), F (HDSL)
Disturbing Frequency	196 kHz (Range = 20 kHz to 1104 kHz)
Pass Threshold	≥ 40 dB (Range = 0 to 70 dB)

Running a WB Longitudinal Balance Test

To run a WB Longitudinal Balance test, do the following:



1. From the XDSL Toolbox, select **WB Long. Balance** and press .

The WB Long. Balance connection diagram is displayed.

2. Follow the on-screen instructions to connect the **Sending Unit** (another CopperPro or TN2100 “Terminator”) and **Receiving Unit** (measuring CopperPro) to both ends of the test pair.

Note

The Receiving Unit’s Ground lead must be disconnected for this test.

3. If the “Sending Unit” is another CopperPro, set it up as the WB Long. Balance **Sending Unit**, and press  on its keypad. If the “Sending Unit” is a Terminator, just turn it on.
4. Select **Receiving Unit** for the measuring CopperPro, and press .

The receiving tester commands the far-end device to apply a longitudinal disturbing signal having a known, preset level on the pair. It then measures the resulting T-R signal (at the applied frequency) caused by pair imbalance to Ground. The WB Longitudinal Balance of the pair is the level of the disturbing signal (in dBm) minus the level of the measured T-R signal (in dBm).

WB Longitudinal Balance Test Results

Test results are displayed on the receiving tester, as shown in Figure 5-13, in the upper right corner of the screen. Failing values are highlighted in flashing reverse-video format. This test was run with a disturbing frequency of 196 kHz and the “F” filter (as indicated) to qualify the pair for HDSL service.

5. Press  (**Contin WB Long. Bal.**) to view balance results in real-time.

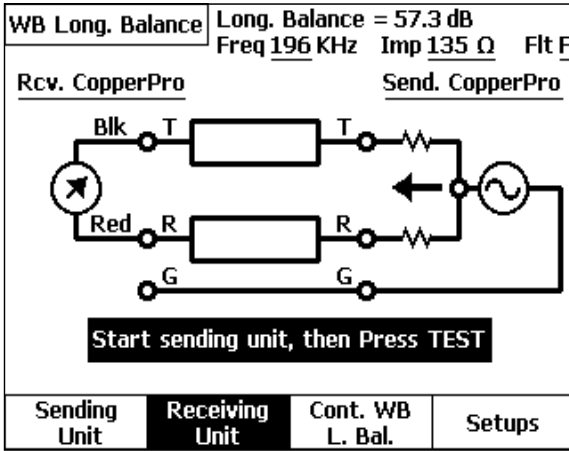

acy102s.eps

Figure 5-13. WB Longitudinal Balance Test Results

Send WB Tone Function

The Send WB Tone test continuously transmits a single precision tone at a level of 0 dBm.

Setting Up a Send WB Tone Test

To set up the Send WB Tone test, follow the instructions under “Displaying a Setup Menu” in Chapter 3. Refer to Table 5-4 for setup parameters.

Table 5-4. Send WB Tone Test Setup Parameter



Parameter	Setting (default in bold)
Termination Impedance	100 Ω or 135 Ω

Running a Send WB Tone Test

To run a Send WB Tone Test, do the following:

1. From the XDSL toolbox, select **Send WB Tone** and press .

The **Send WB Tone** screen is displayed.

2. Press  (**Enter Send Frequency**). Enter the desired frequency, between 10 kHz and 1200 kHz, then press .

3. Press .

The tester begins sending the specified tone.

4. To stop sending the tone, press  or .

ADSL Auto-Test

The ADSL Auto-Test is a double-ended test that performs essentially the same WB Loss sub-test included in the DSL Auto-Test described earlier in the chapter, with **ADSL** chosen as the Qualified Service. The test performs a rapid, yet comprehensive ADSL DMT (Discrete Multi-Tone) transmission test on the pair, compliant with ANSI T1.413 standard frequencies. It provides the following results:

- Predicted Upstream and Downstream Data Rates achievable on the line.
- Insertion Loss values at each ADSL DMT frequency (8 kHz to 1104 kHz).
- Signal-to-Noise Ratio (SNR) values at each ADSL DMT frequency.
- Encoded number of Bits / Tone at each ADSL DMT frequency.

The test requires another CopperPro or TN2100 “Terminator” at the far end of the pair to act as the “Sending Unit”. The units automatically communicate with each other over the test pair, so you don’t need a separate control pair.

Setting Up an ADSL Auto-Test

1. From the XDSL Toolbox, select **ADSL Auto-Test** and press  (**Setups**).

The **Setups – ADSL Auto-Test** screen is displayed. Refer to Table 5-5 for descriptions of the parameters and their settings.

Table 5-5. ADSL Auto-Test Setup Parameters

Parameter	Setting (default in bold)
ADSL Standard	ANSI (Full) or G.Lite
Noise Measurement Filter	G (ADSL) or None, E (ISDN BR), F (HDSL)

2. Change the Setup parameters, if desired.
 - ANSI: Runs a frequency sweep of the full ADSL spectrum (8 kHz to 1104 kHz), with a data encoding limit of 15 Bits / Tone.
 - G.Lite: Runs a truncated sweep (8 kHz to 552 kHz), with a maximum data encoding limit of 8 Bits / Tone.

Running an ADSL Auto-Test

1. From the XDSL Toolbox, select **ADSL Auto-Test** and press .
The **ADSL Auto-Test** connection screen is displayed.
2. Connect the Sending and Receiving Units as shown in the diagram.
3. If the “Sending Unit” is another CopperPro, press (**Sending Unit**), then press .
3. If the “Sending Unit” is a TN2100 “Terminator”, simply turn it on.
4. On the “Receiving Unit”, select (**Receiving Unit**) and press .

ADSL Auto-Test Results

During the ADSL Auto-Test, the “Receiving Unit” commands the “Sending Unit” to transmit composite groups of frequencies at preset levels, and then measures them. At the completion of the test, The “Receiving Unit” displays a wideband Loss graph, as shown in Figure 5-14.

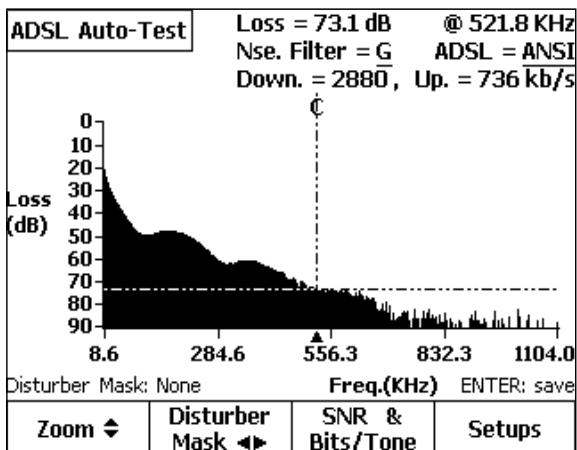

acy66s.eps

Figure 5-14. ADSL Auto-Test Results: Loss Graph

Insertion Loss at the selected frequency, Downstream and Upstream predicted data rates, and setup parameters are displayed at the top of the screen.

5. (Zoom) and (Disturber Mask) softkeys operate as described earlier.
6. Press (SNR & Bits / Tone) to view the SNR Graph, and press it once again to view the Bits / Tone Graph. Refer to Figures 5-5 and 5-6 (DSL Auto-Test Loss Results) for examples of these graphs.

Terminated WB Tests

Terminated WB Tests are similar to the Terminated VF Tests described in Chapter 4, but employ *wideband* rather than *voiceband* tests, in order to qualify pairs for high-speed digital services.

These tests require a far-end terminating device such as the Fluke Networks TN2100 “Terminator” (or another CopperPro running in the “Terminator Emulator” mode) or SmartStrap, 3M “FED” or “FEDI”, or CMC “My Helper”. As in the VF tests, the CopperPro automatically controls the Terminator, FED and Helper units over the test pair.

Setting Up a Terminated WB Test

Refer to “Setting Up a DSL Auto-Test” earlier in this chapter, as the setup procedure for the Terminator and FED WB Auto-Tests is the same as previously described. The SmartStrap procedure is different in that you must select the SmartStrap access pair, and the only Service Type selection is **All**.

Running a Terminated WB Test

To run a Terminated WB test, do the following:

1. From the XDSL Toolbox, select **Terminated WB Tests** and press .

The **Select Terminated WB Test Type** screen is displayed, with the following selections available:

- a) (**Terminator WB Auto-Test**) – This function is exactly the same as the DSL Auto-Test described earlier in the chapter. It appears as well in this test group for convenience. It employs a Fluke Networks TN2100 “Terminator” (or another CopperPro in the “Terminator Emulator” mode) as the far-end device.
- b) (**SS WB Auto-Test**) – This function is similar to the Terminator WB Auto-Test, but employs a Fluke Networks SmartStrap as the far-end device.

- c)  (**FED WB Auto-Test**) – This function is similar to the Terminator WB Auto-Test, but employs either a FED or FEDII as the far-end device. The CMC “My Helper” operates the same as the FED units.

Note

All the above Auto-Tests are similar in operation. However, only the TN2100 “Terminator” is capable of sending composite, wideband tone-sets. As a result, the Terminator WB Auto-Test is much faster, and yields more comprehensive test results.

2. The **WB Auto-Test** connection diagram for the corresponding far-end device is displayed.
3. Connect the units as shown in the displayed connection diagram, select the desired test option (**Pair 1 Test** or **Pair 2 Test**), and press .

The CopperPro displays on-screen the test it is currently running. When completed, a Summary Results screen is displayed similar to that shown in Figure 5-3 under “DSL Auto-Test Results”.

4. Refer to procedures described earlier in the DSL Auto-Test section to view detailed results.

Saving Terminated WB Test Results

Refer to the procedure in “Saving DSL Auto-Test Results” for saving Terminated WB Test results.

Impulse Noise Test

The Impulse Noise test is a single-ended test that enables wideband noise transients of specified amplitude to be counted and recorded over a user-specified time. The results of this test can be particularly helpful for tracking intermittent noise problems. Used in conjunction with the WB Noise / Level test, the Impulse Noise test can help you pinpoint sources of external noise.

Setting Up an Impulse Noise Test

To set up an Impulse Noise test, follow the instructions under “Displaying a Setup Menu” in Chapter 3. Refer to Table 5-6 for setup parameters.

Table 5-6. Impulse Noise Test Setup Parameters

Parameter	Setting (default in bold)
Termination Mode	Terminated or Bridged
Termination Impedance	135 Ω or 100 Ω
Measurement Filter	No or E (ISDN BR), F (HDSL), G (ADSL)
Test Time Setting	15 minutes (Range = 1 to 1440 minutes)
Counter Threshold	> -40 dBm (Range = 0 to -40 dBm)
Pass Threshold	< 10 counts (Range = 0 to 999 counts)

Running an Impulse Noise Test

To run an Impulse Noise test, do the following:

1. From the XDSL toolbox, select **Impulse Noise** and press .
2. Press to start the test.

The CopperPro begins counting noise transients that exceed the **Counter Threshold** level in Setups.

The test automatically stops when the displayed **Elapsed Time** value reaches the **Test Time Setting** entered in Setups. The displayed **Impulse Count** value is highlighted in flashing, reverse-video when it exceeds the **Pass Threshold** entered in Setups.

Impulse Noise Test Results

Figure 5-15 shows you an example of a **WB Impulse Noise** test results screen.

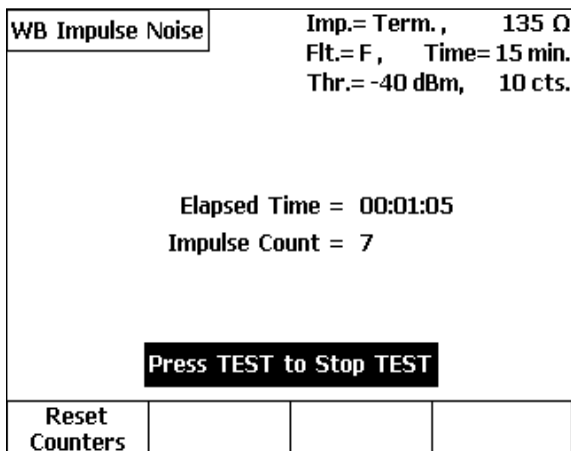

acy105s.eps

Figure 5-15. WB Impulse Noise Test Results

3. To reset the **Elapsed Time** or **Impulse Count** at any time during the test, press (**Reset Counters**).
4. To change the setup for the test, press to stop the test. Then, press (**Setups**). After you make setup changes, press to re-start the test.

Chapter 6

TDR Testing and Fault Location

Introduction

This chapter describes the CopperPro's TDR (Time Domain Reflectometer) test. The TDR testing function is a separately packaged and purchased software option that can often help you locate loop faults with greater precision than the parametric fault location tests that are described Chapter 4. With TDR, not only can you confirm the results of the basic parametric tests, but when you use TDR in conjunction with those tests, you can also vastly improve your ability to accurately measure the distance to faults in a cable.

The TDR Auto-Test function combines both frequency domain (parametric) and time domain (TDR) testing functions in the same package. This combination not only provides a rapid learning curve (due to the consistent user interface), but also gives you with a truly powerful—yet cost-effective—testing solution.

Comparing Parametric Tests to the TDR Test

Table 6-1 provides an overall assessment of the accuracy of the TDR test and three parametric tests (Opens, Load Coils, and RFL) at locating six common cable faults. The table highlights both the versatility of the TDR test as well as the complementary nature of all of the tests and their relative strengths and weaknesses. You may want to refer to this table when trying to decide which tests to use in a particular situation.

Table 6-1. TDR vs. Parametric Fault Location Tests

Type of Cable Fault	CopperPro Tests			
	TDR	Opens	Load Coils	RFL
Open Conductor	Excellent	Excellent	–	–
Partial Open (Bad Splice)	Excellent	Poor	–	–
Split Pair	Excellent	Fair	–	–
Bridged Tap	Excellent	–	–	–
Undesirable Load Coils	Distance: Excellent Count : -	–	Distance: Fair Count : Good	–
Resistive Fault	Excellent ($R_i < 1 \text{ k}\Omega$)	–	–	Excellent (any R_i)

What Happens During a TDR Test: An Overview

You can use the TDR test to determine the length of a cable and to precisely locate faults along the cable. When making a TDR measurement, the CopperPro applies a balanced, high-frequency drive pulse to the test pair. Any fault in the cable causes some of this pulse to reflect back to the CopperPro. The tester captures these reflections (also called echoes), which can be caused by the faults described later (see “Reflections”). The CopperPro measures the amount of time it takes for the pulse it transmitted to return, then uses that time to calculate the distance to the source of the reflection (the fault).

The elapsed time between the transmission of a pulse and its reflection is measured by a highly accurate clock source. Based on the velocity of propagation (VOP) of the pulse, the CopperPro converts the time to distance. The type of cable you are testing determines the VOP, which is defined as the ratio of the speed of the pulse in the cable to the speed of light. For example, a cable with a VOP of 0.64 transmits a pulse at 64% of the speed of light.

Length Measurements and VOP

To obtain accurate length measurements, you must choose the right cable type or supply the correct VOP of the cable that you are testing. The more accurate the VOP, the more accurate the CopperPro’s measurement of the distance to the source of the reflection (the fault). The CopperPro stores VOP values for standard cable types in its memory. Be aware that actual VOP values can vary (see “Determining the VOP” later in this chapter). Therefore, if accurate length measurements are critical to your testing process, you should specify *actual* VOP values when you set up the test. Most cable manufacturers supply VOP information in their specifications.

Reflections

Reflections are caused by discontinuities in a cable's characteristic impedance, such as gauge changes, splices, faults, the cable's end, or series network elements. Positive (in-phase) reflections result from sudden increases in cable impedance, such as those due to opens, load coils, or resistive splices.

Negative (out-of-phase) reflections result from decreases in cable impedance, such as those due to resistive faults (for example, shorts, grounds, and crosses), bridged taps, and build-out capacitors. A cable that has no faults or network elements and is properly terminated in its characteristic impedance generates no reflections.

TDR Auto-Test

The TDR Auto-Test is an automatic test. With the press of a single key, this Auto-Test runs a sequence of parametric tests and a TDR test. Results from a TDR Auto-Test can give you a quick— yet comprehensive— view of the status of a pair. For the novice or infrequent operator of TDR equipment, the TDR Auto-Test can provide a good starting point in the troubleshooting process.

The TDR Auto-Test automatically flags and pinpoints the location of the following types of faults:

- Open conductors
- Resistance shorts
- Load coils
- Bridged taps
- Bad splice joints
- Pair Splits

Even though the individual TDR tests (described later in this chapter) can be performed on working pairs with voltage, the TDR Auto-Test should be run on non-working pairs only. This is because several of its integrated parametric tests (for example, Opens and Shorts & Grounds) are accurate only when there are moderate amounts of voltage on the line.

Setting Up a TDR Auto-Test

To set up the Auto-Test, complete the following:

1. From the **Main** menu, select **TDR Auto-Test**. Then, press **[F4]** (**Setups**).
2. On the setup screen, select the cable type and gauge (refer to Table 6-2) for the cable you are testing.

Note

Before you run the test, you must select the proper Cable Type and Gauge. If these two parameters are specified, the CopperPro automatically uses the industry-standard VOP for that cable type and gauge. If the actual VOP is known, however, you can supply it as well, thus creating a custom cable type for the test.

3. Select the **Pulse Width** from the seven options. Use **Auto** (default) to auto-range and find the largest reflection, regardless of range. If interested in reflections within a particular range of the cable, select the pulse width corresponding to the desired range.
4. Use the filter (**Filtr**) only if a high level of power influence is on the pair.
5. Use averaging (**Avg**) to smooth out instantaneous noise bursts.
6. If less sensitivity to reflections is desired, enter a lower value for **Fault Detect. Sensitivity**. If more sensitivity is needed, increase this % value.
7. Set up the individual parametric tests.

To do this, you need to display the setup screen for each test and complete the setup (see the relevant sections in Chapter 4 for setup instructions for each test).

Table 6-2. TDR Auto-Test Setup Parameters

Parameter	Setting (default in bold)
Pulse Width (Range)	Auto , 20 ns (500 ft), 100 ns (2000 ft), 500 ns (4000 ft), 1000 ns (6000 ft), 2500 ns (12,000 ft), 5000 ns (>12,000 ft)
Cable Gauge	19, 22, 24 , 26, 28 AWG
Cable Type	Jelly Filled , Air Core, Pulp, JKT, 5 Pr. Bur. Drop, 2 Pr. Bur. Drop, 1 Pr. Aerial Drop, Univ. Drop, Custom
VOP	0.589 (Range = 0.300 to 0.999)
Filter	OFF , ON
Average	OFF , ON
Fault Detect Sensitivity	97.0 (Range = 1.0 to 100.0 %)

Starting and Stopping a TDR Auto-Test

To run a TDR Auto-test, display the **Main** menu. Select **TDR Auto-Test**, then press .

The Auto-Test begins, running the following tests in the order listed:

- Voltage
- Shorts & Grounds
- Opens
- Load Coils
- Auto-ranging TDR

To stop the Auto-Test at any time, press .

TDR Auto-Test Results

When the TDR Auto-Test ends, the CopperPro displays the **TDR Auto-Test** result screen (Figure 6-1):

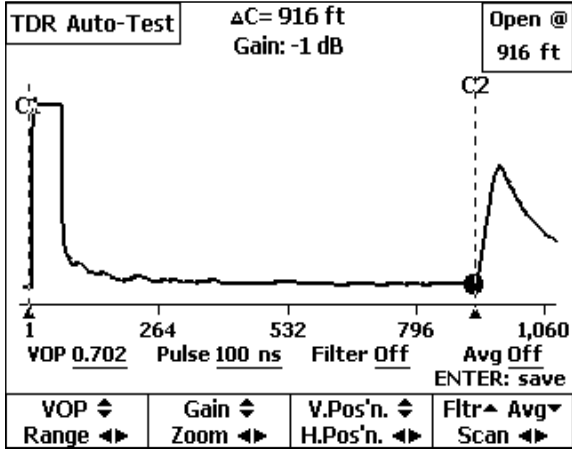

acy71s.eps

Figure 6-1. TDR Auto-Test Results: Open

Figure 6-1 is a typical TDR Auto-Test result screen. It has the following elements:

- **Pair Status Message:** shown in the upper right corner of the screen and highlighted (**Open @ 916 ft**). This is a final overall result that the CopperPro derives by interpreting results from all of the individual tests that it runs. The **Gain** setting displayed at the top center of the screen refers to the current amount of magnification used to display the trace.
- **Launch Pulse:** appears as the larger, positive pulse on the left side of the screen.
- **Launch Cursor (C1):** the vertical line that marks the start of the launch pulse. To manually move the launch cursor, press \odot to move right and \ominus to move left.
- **Reflection Pulse(s):** appear as smaller positive pulses (as seen in Figure 6-1) or negative pulses to the right of the launch pulse.
- **Reflection Cursor (C2):** the vertical line that marks the position of the largest reflection pulse. To manually move the reflection cursor, press \ominus to move right and \odot to move left.
- **TDR test parameters:** shown in the top center portion and base of the screen. The symbols and abbreviations have the following meanings:
 - ◆ **ΔC :** Distance between position of launch cursor and reflection cursor.
 - ◆ **Range or Pulse:** Launch pulse-width (in nanoseconds).
 - ◆ **Fltr:** Power filter status (in Figure 6-1, the user turned it off).
 - ◆ **Avg:** Trace smoothing filter (in Figure 6-1, the user turned it off).
 - ◆ **VOP:** Velocity of propagation factor that is specified in the setup.

- **TDR softkeys:** alternate action softkeys that activate the functions described in Table 6-3. The softkey is highlighted when the function is activated. To deactivate a function, press its softkey again.

The TDR Auto-Test is a snapshot function. After the test ends, you can press any of the softkeys that are listed in Table 6-3 except **Range**, **Filtr**, and **Avg**. You must select the filters before you run the Auto-Test. The pulse-width is automatically determined during the Auto-Test.

- **Highlighted TDR Auto-Test Result Types:** Fault types and marking tags that are automatically identified are as follows:
 - ◆ **Open, T Open, R Open** (“Full Circle”, “Upper ½”, “Lower ½”)
 - ◆ **Short** (“Star”)
 - ◆ **B. Tap** (Bridged Tap, “T”)
 - ◆ **L. Coil** (Load Coil, “Diamond”)
 - ◆ **Splice** (High resistance open or splice joint, “Triangle”)
 - ◆ **Split** (“+”)

Table 6-3. TDR Auto-Test Softkeys







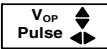

Press this key first	Then press
	<p>The  or  key to respectively increase or decrease the current VOP value from 0.300 to 0.999.</p> <p>The  or  key to respectively decrease or increase the pulse width from 20 ns to 5000 ns.</p>
	<p>The  or  key to respectively increase or decrease the waveform vertical gain (size).</p> <p>The  or  key to respectively compress or expand the waveform horizontal scale about the reflection cursor.</p>

Table 6-3. TDR Auto-Test Softkeys (continued)

Press this key first	Then press
	<p>The ⤴ or ⤵ key to respectively move the entire waveform up or down in the display window.</p> <p>The ⤴ or ⤵ key to respectively move the entire waveform left or right in the display window.</p>
	<p>The ⤴ key to apply the Power Filter (Filtr). Press ⤴ again to remove the filter.</p> <p>The ⤵ key to apply the Averaging Filter (Avg). Press ⤵ again to remove the filter.</p> <p>The ⤴ or ⤵ key to respectively move Cursor 2 (C2) left or right (Scan) to the next detected reflection on the displayed waveform. If the next reflection is outside of the current view, the waveform automatically shifts position to bring it into view.</p>

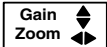
Note

The tester is designed to automatically find and classify reflections based on a complex set of testing algorithms. However, due to the variety of cable types and faults that may be encountered, a visual waveform interpretation may be required to resolve the actual problem. For example, the tester in one case may mark a reflection at its peak rather than its start due to line noise, and misinterpret the cause. In this case, manually move the reflection cursor to the start of the reflection to get the proper distance and re-evaluate the cause based that shape of the reflection.

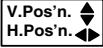
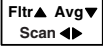
Saving TDR Auto-Test Results

The TDR Auto-Test waveform is a snapshot result that you can save in a file. To save a result, press **ENTER**, then follow the prompts for naming and saving the file. For details, see Chapter 7 “Saved Test Results”.

The TDR Toolbox

The TDR toolbox is shown in Figure 6-2. The tests in this toolbox enable you to perform a variety of individual measurements on a pair. These tests are described separately later in this section.



Pair 1 Test	Pair 1 & 2 Compare	Pair 1 - 2 Difference	Pair 1 Monitor
TDR Auto-Test	Pair 2 to 1 Crosstalk	Recall Trace	Compare Recall & P1
<p>(Apply TDR Signal to Pair 1)</p> <div style="background-color: black; color: white; padding: 5px; display: inline-block; margin: 10px auto;"> Press TEST to Start </div>			
POTS O—C	XDSL O—C	TDR O—C	Setups

Figure 6-2. TDR Toolbox

acy72s.eps

Starting and Stopping a Test in the TDR Toolbox

Unless otherwise instructed, use the following procedure to start a test in the TDR toolbox.

1. From the **Main** menu, press  (**TDR**) to display the TDR toolbox (Figure 6-2).
2. Select the test that you want to run, then press .

To stop a running test, press .

Saving TDR Test Results

For those tests that display a continuously updated “live” trace, you can save a snapshot of the trace. To do this, press . Then, follow the prompts for naming the file and saving it. For details, see Chapter 7 “Saved Test Results”.

Pair 1 Test

The Pair 1 test is the basic TDR “auto-ranging” test tool. In this test, a launch pulse is continuously applied to Pair 1, and the resulting reflections are continuously displayed. The resulting waveform is a single trace on the screen.

The Pair 1 test result screen is similar to that shown in Figure 6-1 except that the CopperPro does not display pair status information. The launch cursor marks the beginning of the launch pulse. The reflection cursor marks the *approximate* start of the largest reflection, and **ΔC** automatically gives the approximate distance to the reflection.

The Pair 1 test uses pre-selected VOP and filter settings. However, you can change these settings in real time after the test begins. The test automatically searches for reflections, initially changing pulse-widths and vertical and horizontal scales to present the clearest possible picture of the largest reflection.

After determining the best set of parameters for the specific type of reflections that it detects, the CopperPro displays a *continuous* image of the waveform on the screen. If you want to see the effect of a different pulse width or filter, you can do so at any time, with the continuous test automatically displaying the resulting waveform.

Note

The reflection cursor is automatically positioned as close as possible to the leading edge of the largest reflection. However, it is recommended that you manually expand the horizontal (Zoom) and vertical (Gain) scales in order to zero in on the reflection. Then move the reflection cursor until it is at the leading edge of the reflection and until it just begins to move off the horizontal baseline. The ΔC value should now be the most accurate possible distance to the fault.

After a waveform is displayed, you can force the unit to increase or decrease its pulse width by pressing \square (**Range**) and then \leftarrow or \rightarrow . To go back to the **AUTO** pulse width, press \rightarrow until **AUTO** is displayed. This procedure may be used on all continuous TDR tests.

Pair 1 and 2 Compare Test

The Pair 1 and 2 Compare test enables you to see continuous TDR waveforms from Pair 1 (T and R) and Pair 2 (T1 and R1) simultaneously. This test is typically used to compare a good pair (Pair 1) with a suspected faulty pair (Pair 2) in the same count so that you can see the differences between the two more closely.

Figure 6-3 shows a typical Pair 1 and 2 Compare test result screen. The TDR softkeys operate in the same manner as those on the Pair 1 test result screen (see “Pair 1 Test” and Table 6-3 for descriptions).

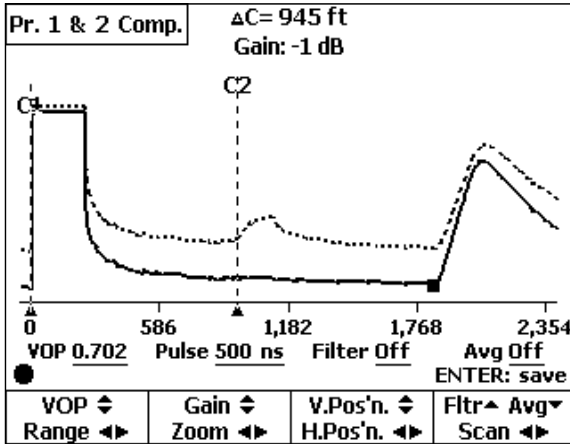

acy73s.eps

Figure 6-3. Pair 1 and 2 Compare Test Result Screen

Pair 1 is *always* depicted as the lower trace and shown as a solid line. Pair 2 is the upper trace, which is shown as a dotted line. In Figure 6-3, note that the trace for Pair 2 has a minor reflection (it is marked by the reflection cursor) that indicates a gauge change at a splice point.

Pair 1 - 2 Difference Test

This test is similar to the Pair 1 and 2 Compare test. The main difference between the two tests is that in the Pair 1-2 Difference test, the CopperPro internally computes the mathematical difference between the two waveforms and displays the difference as a *single* trace. This presentation is especially helpful for helping you see minor differences between two pairs—one good and one suspect.

Pair 1 waveform data is used as the reference, and Pair 2 data is subtracted from it to obtain the “difference” waveform. If both pairs are identical (have *exactly* the same waveforms), the result is a straight line with no reflections.

The TDR softkeys operate in the same manner as those on the Pair 1 test result screen (see “Pair 1 Test” and Table 6-3 for descriptions).

Pair 1 Monitor

The Pair 1 Monitor test can help you track down intermittent faults. The test operates continuously (like the Pair 1 Test), but the CopperPro records waveform differences over time on the screen.

Figure 6-4 shows the results from a Pair 1 Monitor test that was conducted on a pair with an intermittent splice connection.

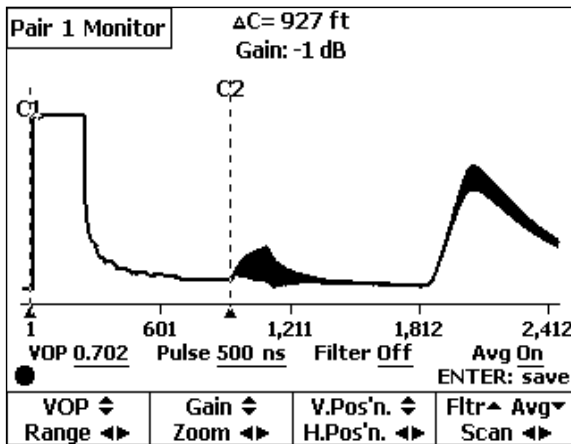

acy74s.eps

Figure 6-4. Pair 1 Monitor Test Result: Intermittent Splice

The TDR function keys operate in the same manner as they do on the Pair 1 test result screen (see “Pair 1 Test” and Table 6-3 for descriptions).

You can change the cursor positions at any time without affecting the displayed waveform. However, if you operate any of the other softkeys, you will erase the previously stored deviations and the waveform will start anew from that point.

Pair 2 to 1 Crosstalk Test

The Crosstalk test is useful for locating resistive crosses between pairs that are typically caused by the breakdown of insulation due to water in a cable. This test is also helpful for determining the location of a pair split and the location of a split repair, when both split pairs are connected.

In this test the CopperPro applies launch pulses on Pair 2, but measures any coupled reflections on Pair 1. The signal level of the resulting single trace is directly proportional to the leakage between the two pairs, and the position of the reflection occurs at the point of the leakage.

Note

The launch pulse does not appear on the Crosstalk test result screen because it is launched on Pair 2. The result screen shows only the signals occurring on Pair 1. However, any resulting influence on Pair 1 from the pulse, which may include slight coupling spikes from the Launch Pulse leading and trailing edge, is displayed.

The TDR softkeys operate in the same manner as those on the Pair 1 test result screen (see “Pair 1 Test” and Table 6-3 for descriptions).

Displaying and Deleting Saved Traces

To display or delete a saved trace, complete the following:

1. From the TDR toolbox (Figure 6-2), select **Recall Trace**.
2. Press .
3. Press or to select the trace file.
4. Do one of the following:
 - To display a file, press .

The selected trace is displayed. Note that the waveform is static, which means that it is not continuously updated. Therefore, the real-time **Range** or **Pulse** and **Filter** softkeys are not available for use.

You can use the cursor, **VOP**, **Gain**, **Zoom**, **Vertical**, and **Horizontal** softkeys. These keys operate in the same manner as they do on the Pair 1 test result screen (see “Pair 1 Test” and Table 6-3 for descriptions).

- To delete a file, press **Delete** (for details, see Chapter 7, “Saved Test Results”).

Compare Recall and Pair 1 Test

The Compare Recall and Pair 1 test is used to compare a previously stored trace with a “live” trace on Pair 1. The format of the results is like those shown in Figure 6-3, in which two “live” signals are displayed for comparison. In this test, Pair 1 is shown as the lower trace with a solid line, and the previously stored trace is shown as the upper trace with dotted lines.

You cannot use the real-time **Range** or **Pulse** and **Filter** softkeys on the result screen. The remaining softkeys operate in the same manner as those on the Pair 1 test result screen (see “Pair 1” and Table 6-3 for descriptions).

TDR Test Operating Tips

The operating tips in this section are provided to help you in the “real world” of TDR testing.

Determining the VOP

When you select a **Cable Type** and **Gauge** in the setup for the test, the CopperPro automatically uses a standard median VOP value. Several factors, however, can make this value erroneous and cause the tester to incorrectly determine the location of a fault:

- Multiple gauges in the cable makeup
- Cable dielectric differences between manufacturers
- Dielectric variation with temperature (1% per 10°C)
- Water in the cable
- Age of the cable.

The following procedure outlines a reliable method for calibrating the VOP factor to a particular cable type:

1. Locate a known *good* pair in the same binder group as the test pair.
2. Find the pair’s *exact* length. There are several ways to do this:
 - Run an Ohms-to-Distance test with the far end shorted and with the gauge configuration known.
 - Run an Opens test, using the proper cable type.
 - “Wheel off” the length with a measuring wheel (taking slack loops or “snaking” into account).

3. Run the TDR Pair 1 test on the known good pair.
4. Align the reflection cursor on the *exact* leading edge of the pair's positive "open" reflection.
5. Adjust the VOP until the "Delta C" (ΔC) distance equals the known length.
6. Use this value of VOP for testing the faulty pairs.

Double-ended Testing

To further minimize errors during TDR testing, it is advisable to test from both ends of the cable. If the sum of the "Delta C" (ΔC) distances to the same fault (from testing from both ends) does not equal the known section length, adjust the VOP factor and re-test from both ends. When the sum of the "Delta C" distances equals the section length, you have found the exact location of the fault.

Another method entails mathematically deriving the exact fault distance (without having to adjust VOP and re-test multiple times). However, this method requires that the exact section length be known. To obtain an exact distance, do the following:

1. Test the faulted pair from both ends and record both "Delta C" distances to the *same* fault (D1 and D2).
2. Calculate the Correlation Factor (CF) by dividing the known section length (L) by the sum of the two distances: $CF = L / (D1 + D2)$

3. Multiply each of the two distances by the CF to get the corrected distance (CD) to the fault from both ends:

$$CD1 = CF \times D1 \text{ and } CD2 = CF \times D2$$

Example: Known section length $L = 1200$ feet

$$\text{TDR Measurement } D1 = 400 \text{ feet}$$

$$\text{TDR Measurement } D2 = 600 \text{ feet}$$

$$CF = 1200 / (400 + 600) = 1.20$$

$$CD1 = 1.2 \times 400 = 480 \text{ feet}$$

$$CD2 = 1.2 \times 600 = 720 \text{ feet}$$

$$\text{Section Length} = CD1 + CD2 = 1200 \text{ feet (sanity check)}$$

Testing for Faults Close to the CopperPro

Reflections that occur before the launch pulse has been completed (due to faults that are very near the CopperPro connection) can be distorted or even completely masked by the launch pulse itself. In these cases, to get a clearer picture of the reflection, attach a *known* length of jumper wire (of the same type and gauge as in the cable, if possible) to the CopperPro test leads to compensate for the pulse's width. An extension of about 10 to 15 feet in length should cover *all* applications, using the CopperPro's shortest pulse-width.

Chapter 7

Saved Test Results

Introduction

This chapter shows you how to save test results in the CopperPro's memory. You will also learn how to view and print saved test results and how to upload them to a PC.

Saving Test Results

The CopperPro saves results in two types of files:

- Text-based files

Text-based files consist of data that is comprised solely of alphanumeric characters and special symbols. The results of simpler tests, such as the Voltage, Shorts and Grounds, and Opens tests, are stored as text-based files.

- Graphical files

Graphical files consist of data that is represented by a waveform (in the case of TDR) or a frequency sweep graph. The results of more complex tests, such as the TDR, Noise, Level, and Loss tests, are stored as graphical files.

Storage Limitations of Saved Result Files

The CopperPro stores text-based test results in a circular buffer, so that as additional files are saved, older files are eventually overwritten. The tester's available storage capacity differs depending on the type of test result.

Graphical results require much more storage space than text results. Therefore, there is a limit to the number of graphical files that the tester can store.

Graphical files are not automatically overwritten like text-based files are, but can be manually deleted. Text-based files, on the other hand, take up less space

so the tester can store more files of this type. Table 7-1 gives you an indication of the tester's storage limitations for text-based files and the two types of graphical files.

Table 7-1. Storage Limitations of Saved Result Files

Type of File	Space Limitation
Text-based	Approximately 10,000 lines of data
Graphical TDR waveform	Ten files
Graphical frequency sweep	Ten files

Result File Header

When the tester stores a result, it saves it under a header. The top portion of Figure 7-3 shows you an example of a header. The header contains the following information:

- **Wire Center Name**
A user-supplied name that identifies the primary work location. For instructions on how to specify or change the Wire Center name, see “Creating a Custom Header for Test Result Files” in Chapter 3.
- **Facility Cable Number**
A user-supplied number that identifies the specific cable on which a test was performed. For instructions on how to supply or change this number, see “Generic and Test-Specific Setup Parameters” in Chapter 3.
- **Pair/Terminal Number**
A user-supplied number that identifies the specific single cable pair, cross-box binding post, or inside terminal number on which a test was performed. For instructions on how to supply or change this number, see “Generic and Test-Specific Setup Parameters” in Chapter 3.
- **Date/Time Stamp**
A record of the date and time that the test was conducted. The CopperPro automatically supplies this information.

If you do not supply the information in the aforementioned list, the header contains a Date/Time stamp only. Operator Name, Location, and Job Number can optionally be added to the header.

If a group of results shares the same header information (that is, Wire Center name, Facility Cable Number, and Pair/Terminal Number), one header appears immediately before the first saved result in the group and is not repeated for each subsequent result. This convention is used to conserve memory.

However, any time you modify the information that is used for the header, the change is reflected in a new header that appears immediately before the group of results it pertains to.

If the elapsed time between tests is greater than ten minutes, the tester places a timestamp before the next test result. If the elapsed time between a group of tests is less than ten minutes, a timestamp is not posted before each result.

Again, the purpose of this convention is to conserve memory.

Test results with the same Wire Center name are listed in the order in which the tests were conducted and under the name of the specific test. This grouping of results under a common Wire Center name allows results for multiple tests on the same pair to be easily identified.

Storing Test Results Automatically

The CopperPro features an automatic test storage option that saves the text-based results of all non-continuous tests except Auto-Tests. All relevant test data is saved and any failures (those results that exceed a preset Pass/Fail threshold) are highlighted in reverse video. Auto-Test results must be manually saved, as they require specific Test Identification information prior to storage.

The automatic test storage option allows you automatically store text-based files only. You must *manually* save graphical files (see “Saving a Displayed Waveform or Frequency Graph”), as well as text results for the Auto-Tests.

The automatic test storage option is enabled when the tester is shipped from the factory. If you want to turn off the option, do the following:

1. On the tester’s front panel, press .

The **Saved Results** selection screen (Figure 7-1) is displayed:

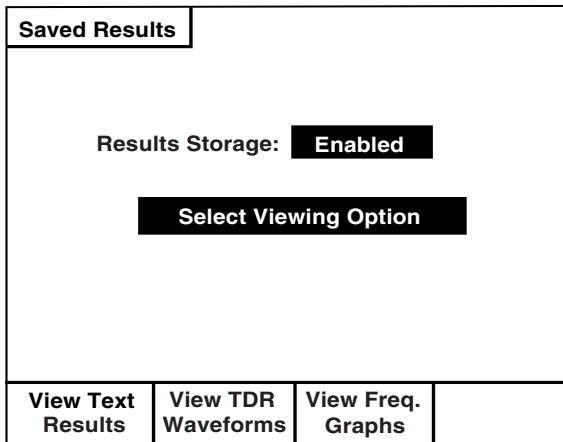

Figure 7-1. Saved Results Selection Screen

acy91s.eps

The **Results Storage** field shows that automatic test storage is **Enabled**.

2. Press (**Edit**) then or to change the automatic test storage setting to **Disabled**.

The tester no longer automatically stores test results.

Saving a Displayed Waveform or Frequency Graph

To save a TDR waveform or frequency sweep graph, do the following:

1. Make sure that the TDR waveform or frequency sweep graph that you want to save is displayed on the tester's LCD.
2. Press .

The list of saved waveforms (see Figure 7-4) or frequency graphs (see Figure 7-5) is displayed.

3. Press or move the cursor to the desired storage position (1 through 10 for a TDR waveform and 1 or 2 for a frequency sweep graph).
4. If you want to make some notes about the waveform or graph, press (**Edit Remarks**). Then, type your notes in the space provided.
5. Press (**Save**).

The waveform or graph is saved in the storage position you selected. The tester also saves the associated setup information (for example, Vop, Pulsewidth, Cursor positions, and Filters employed).

Viewing Stored Test Results

To view test results that are stored in the tester’s memory, press .

The **Saved Results** screen is displayed (see Figure 7-1). From this screen, you can view the following saved results:

- Text-based results
- TDR waveforms
- Frequency graphs.

The following sections provide instructions for viewing the three types of test results.

Viewing Text-based Results

To view stored text-based results, press  (**View Text Results**) on the **Saved Results** screen (Figure 7-1).

The **Select Viewing Option** screen (Figure 7-2) is displayed:

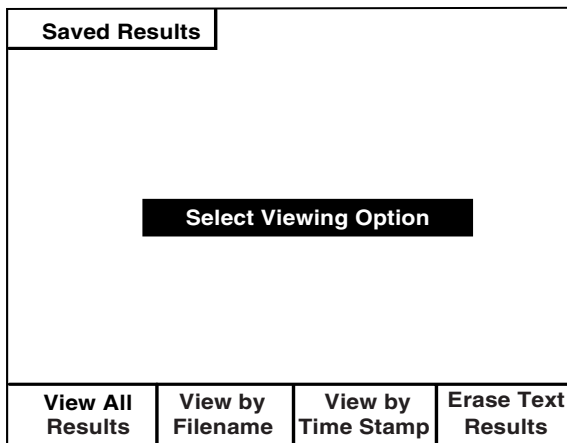

Figure 7-2. Saved Results Screen: Viewing Text Results

acy92s.eps

In Figure 7-2, you can select the following options:

- View all results
- View results for a particular Wire Center
- View results for a certain time period
- Erase all results.

These options are described in the following sections.

Viewing All Results

To view all stored text results, do the following:

1. On the **Saved Results** screen (Figure 7-2), press (**View All Results**).

A screen similar to that shown in Figure 7-3 is displayed. The tester lists all of the text-based results that are stored in memory, beginning with the oldest files (those with the earliest time stamp):

Saved Results			
1005 Riverside Box / Cable 101 / Pair 1001: 12/15/2000, 03:15 PM			
<u>Voltage :</u>	TR :	0.0 VDC,	0.0 VAC
	TG :	0.0 VDC,	10.0 VAC
	RG :	0.0 VDC,	2.0 VAC
<u>Shorts & Grounds :</u>	TR :	>100M	
	TG :	82.5 kΩ	
	RG :	>100M Ω	
<u>Opens</u>	T :	18,750 ft	
	R :	18,880 ft	
	Bal.:	99.3%	
More ⇅	Start	End	Upload

Figure 7-3. Saved Results: All Text Results

acy93s.eps

2. Use these softkeys to navigate through the list:
 - Press **[1]**(**More**) then press **[↑]** to page forward or **[↓]** to page backward.
 - Press **[2]**(**Start**) to display the first screen. The oldest results are on listed this screen.
 - Press **[3]**(**End**) to display the last screen. The most recent results are listed on this screen.

Viewing Results for a Particular Wire Center

The CopperPro groups test results under Wire Center names. If you want to view test results for a particular Wire Center, do the following:

1. On the **Saved Results** screen (Figure 7-2), press **[2]**(**View by Filename**).
A list of Wire Center names with associated results is displayed.
2. Press **[1]**(**More**) until you display the screen containing the desired Wire Center name.
3. Press **[↑]** or **[↓]** to move the cursor to the Wire Center name. Then, press **[2]**(**View**).

The results saved under the Wire Center name you selected are displayed.

Viewing Results for a Particular Period of Time

You can view results of tests conducted during a particular time period. To do this, complete the following:

1. On the **Saved Results** screen (Figure 7-2), press **[3]**(**View by Time Stamp**).
2. When prompted, type both a starting date and time and ending date and time in the space provided.

3. Press (**View**).

Test results for the time period you specified are displayed. The results are listed in chronological order, beginning with the starting date and time that you provided.

Erasing All Results

To erase all saved text results from the tester's memory, do the following:

1. Display the **Saved Results** screen (Figure 7-2).
2. Press (**Erase Text Results**).

All saved text results are permanently deleted from the tester's memory.

Viewing TDR Waveforms

To view stored TDR waveforms, do the following:

1. On the **Saved Results** screen (Figure 7-1), press (**View TDR Waveforms**).

The list of TDR waveforms stored in the tester's memory is displayed, as shown in Figure 7-4:

Saved Results	TDR Waveform List		
<u>Trace No.</u>	<u>Remarks</u>		
1.	HRO — Bad Splice Joint		
2.	Good Pair — 3845 ft		
3.	(Empty)		
4.	(Empty)		
5.	(Empty)		
6.	Open Tip — 320 ft		
7.	Short		
8.	Bridged Tap		
9.	Load Coil — 2800 ft		
10.	(Empty)		
Edit Remarks	View	Erase	Upload

Figure 7-4. Saved Results: List of TDR Waveforms

2. To view a waveform, press \uparrow or \downarrow to select it. Then, press \square_2 (**View**).
3. If you want to edit the notes you made about the waveform, select the waveform, then press \square_1 (**Edit Remarks**). In the space provided, type the desired information.

Deleting a Saved Waveform

To delete a saved TDR waveform, do the following:

1. Display the list of TDR Waveforms (see Figure 7-4). Then, press \uparrow or \downarrow to select the desired waveform.
2. Press \square_3 (**Erase**).

The selected waveform and associated remarks are permanently deleted from the tester's memory.

Viewing Stored a Frequency Sweep Graph

To view a stored frequency sweep graph, do the following:

1. On the **Saved Results** screen (Figure 7-1), press \square_3 (**View Freq. Graphs**).
The **Frequency Sweep Graph List** (Figure 7-5) is displayed:

Saved Results		Frequency Sweep Graph List	
Graph No.	Remarks		
1.	Working ADSL Pair	T1 Crosstalk	
2.	(Empty)		
3.	(Empty)		
4.	(Empty)		
5.	(Empty)		
6.	(Empty)		
7.	(Empty)		
8.	(Empty)		
9.	(Empty)		
10.	(Empty)		

Edit Remarks	View	Erase	Upload
--------------	------	-------	--------

Figure 7-5. Saved Results: List of Frequency Sweep Graphs

acy95s.eps

2. Press \uparrow or \downarrow to select the graph. Then, press \square_2 (**View**).
4. If you want to edit the notes you made about the graph, select the graph, then press \square_1 (**Edit Remarks**). In the space provided type the desired information.

Deleting a Saved Frequency Graph

To delete a saved frequency graph, do the following:

1. Display the list frequency sweep graphs (see Figure 7-5). Then, press \uparrow or \downarrow to select the graph.
2. Press \square_3 (**Erase**).

The selected graph and associated notes are permanently deleted from the tester's memory.

Printing Test Results

To print a saved text result, TDR waveform trace, or a frequency sweep graph, do the following:

1. Connect the CopperPro to a serial graphics printer (see "Connecting to a Printer" in Chapter 2) using the optional Printer Cable.
2. Select the proper printer type in User Options "RS232 Port Setup" (default is Seiko DPU-414).
3. To print a displayed TDR waveform or graph:
 - Press \bigcirc then $\square_{\text{SAVED RESULTS}}$ ("Print Screen" function)
 - Press \square_1 (**Printer**)
 - The screen graphic image will be printed
4. To print text-based test results:
 - Select the desired results (view by wire center, time stamp, or all)
 - Press \bigcirc then $\square_{\text{SAVED RESULTS}}$ ("Print Screen" function)
 - Press \square_1 (**Print Screen**) to print only the results displayed on the screen, then \square_1 (**Printer**) or
 - Press \square_2 (**Print Results**) to print the range of selected results.

Uploading Test Results to a PC

To upload saved test results (both text-based and graphical ASCII files) to a PC, do the following:

1. Connect the CopperPro to a PC (see “Connecting to a PC” in Chapter 2) using the supplied serial cable.
2. Set up a standard PC communications program (HyperTerminal, TeraTerm, etc.) as follows:
 - Baud rate = **38,400** bps, **8** Data bits, **1** Stop bit, **No** Parity, **No** Flow Control.
3. On the tester’s LCD, display one of the following:
 - Text-based results (as shown in Figure 7-3)
 - The list of TDR waveforms with the desired trace selected (as shown in Figure 7-4)
 - The list of frequency sweep graphs with the desired graph selected (as shown in Figure 7-5).
4. Start the PC communications program.
5. Uploading:
 - Text Based Results- Press (**Upload**), then either (**Column Format**) to use the normal column viewing format; or (**Spreadsheet Format**) to use a “tab-delimited” format for direct importing into a spreadsheet program. The ASCII data will begin uploading.
 - TDR Waveform or Graph- Press (**Upload**) and the ASCII data will immediately begin uploading to the PC in tab-delimited format for spreadsheet compatibility.

Note

To transfer a graphic screen image to a PC, rather than the data file described above, see “Transferring a Screen Image to PC” in Chapter 3.

Chapter 8

Updating the CopperPro with New Software

Introduction

Periodically, Fluke Networks releases software updates for your 990DSL CopperPro Loop Tester. When an update is available, you can download it from the Fluke Networks website at <http://www.flukenetworks.com>.

The process of updating the CopperPro with new operating software consists of three basic steps:

1. Connect the CopperPro to a personal computer (PC).
2. Put the CopperPro in download mode.
3. Install the software update program on the PC and download the files to the CopperPro.

This chapter provides instructions for each step in this process.

Before You Begin

Before you begin, you must have the following:

- An IBM compatible PC with these minimum features:
 - ◆ At least one available RS-232 serial port. (The serial port must have a nine-pin interface or an adapter that converts the serial port to a nine-pin interface.)
 - ◆ Windows 95, 98, 98SE, Me, or NT (Version 4.0 or 2000).
- The serial RS-232 cable that was supplied with the CopperPro.
- The ability to connect to the Internet and access the Fluke Networks web site.



Step One: Connect the Tester to a PC

To connect the CopperPro to a PC, complete the following:

1. Connect one end of the supplied RS-232 cable to the nine-pin RS-232 serial port on the tester's side connector panel (see Figure 2-1).
2. Connect the other end of the RS-232 cable to an available serial port on the PC.

Step Two: Put the Tester in Download Mode

To put the CopperPro in download mode, do the following:

1. Turn on the CopperPro.
2. Press , then .

The **USER OPTIONS** menu is displayed.

3. Select **Program Download**. Then press

The CopperPro displays the **DOWNLOAD MODE** screen (Figure 8-1):

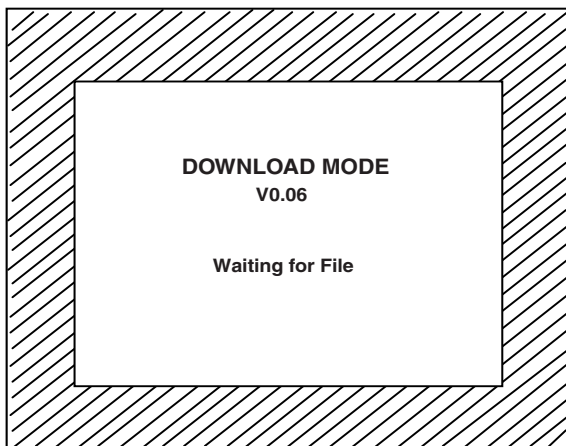

acy89s.eps

Figure 8-1. Download Screen: Waiting for File

The “*Waiting for File*” message indicates that the CopperPro is in download mode and ready to receive the files to update the software.

Note

Another way of entering the download mode is to power the tester up while holding down.

Step Three: Updating the Tester's Software

The update software is available from the Fluke Networks website (www.flukenetworks.com). To obtain the software, your PC must have a connection to the Internet and have a web browser installed that is capable of executing programs from the Internet. Microsoft Internet Explorer Version 5.0 (or later) performs this function. The following instructions assume that you are using Microsoft Internet Explorer 5.0 (or later).

1. Start your Internet Web browser and verify that you have a connection to the Internet.

2. Access the following web address (URL):
<http://www.flukenetworks.com/CopperPro/Update/versionxxx/cpflash.exe>

The browser displays the **File Download** window.

3. In the **File Download** window, select **Run this program from its current location**. Then, click **OK**.

The download process begins. After the program is downloaded, the browser may display a **Security Warning** window.

4. Click **Yes** if the Security Warning window is displayed.

Your PC displays this message: “*Searching for CopperPro*”.

After the program detects the CopperPro, it begins updating the tester’s Flash memory. Messages are displayed on the PC to indicate the type of data that is being transferred from the PC to the CopperPro.

Note

If the program does not detect the CopperPro, it prompts you to supply the correct serial port.

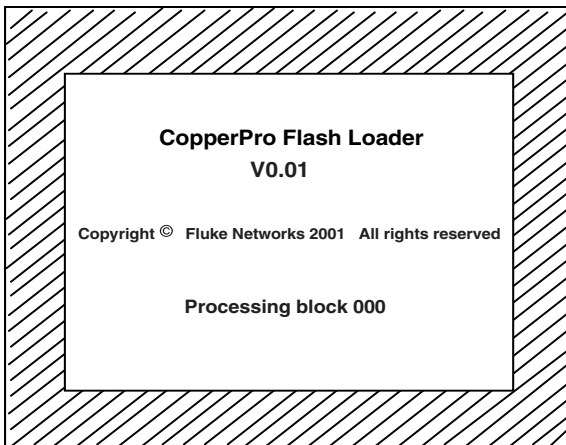

acy88s.eps

Figure 8-2. Final Download Screen

The Flash update occurs in blocks of flash data. The update begins with the highest numbered block and works toward zero. The CopperPro displays this progression as a series of “*Processing block 0XX*” messages. The value XX represents the number of the block that is being transferred. The number of the first block, however, is not determined until the Flash update is created.

After Flash memory block 000 is finished processing (see Figure 8-2), the CopperPro automatically powers down. The download process is completed.

5. Disconnect the RS-232 cable from the PC and the tester.

You can now operate the CopperPro with the new version of software.

Appendices

Appendix	Title	Page
A	Features and Specifications.....	A-1
B	Replacement Parts and Accessories	B-1

990DSL

Users Guide

Appendix A ***Features and Specifications***

Introduction

Appendix A describes the physical and operational characteristics of your 990DSL CopperPro Loop Tester

Physical

Size: (H x W x D): approximately 25 cm x 13.5 cm x 8.1 cm
(9.8" x 5.3" x 3.2")

Weight: 1.8 kg (4.0 lbs.)

Display: 320 x 240 pixel graphic LCD with backlight and adjustable contrast

LED Indicator: charging status indicator (located on the side connector panel)

Communication Port: RS-232 PC and printer port (DB-9)

Power

AC Operation: operates from an external AC adapter/charger

Battery Type: operates from an internal removable NiMH rechargeable battery pack (installed)

Battery Life: a fully charged battery provides approximately 16 hours of normal use

Battery Recharge Time: 2 to 3 hours (in the tester) for a fully discharged battery pack

Environmental

Operating Temperature: -20° C to +60° C (-4° F to +140° F)

Storage Temperature: -40° C to +70° C (-40° F to +158° F)

Battery Charging Temperature: 10° C to 40° C (50° F to 104° F)

Humidity Tolerance (operation without condensation): 95 %

Rain Resistance: IEC60529 IP02, Ingress Protection: water dripping

Vibration: Random, 2 g, 5 Hz to 500 Hz

Shock: 1 Meter Drop Test

Altitude: 4500 m (15,000 ft)

Standards Compliance

Analog Transmission Parameter Measurement: IEEE 743-1995

ADSL Metallic Interface: ANSI T1.413-1998

Regulatory Compliance

Safety: CSA C22.2 No 1010.1

CE:

- EN 61326 Emissions and Immunity CLASS A.
- EN 61010-1 + 2nd amendment

Operational Specifications: Basic 990DSL

Function	Range	Accuracy
AC Voltage	0 V to 250 V	1 % \pm 0.5 V
DC Voltage	0 V to 150 V	1 % \pm 0.5 V
($R_{IN} = 100\text{ k}\Omega$, default;	150 V to 240 V	2 %
1 M Ω or 10 M Ω , optional)	240 to 300 V	3 %
DC Loop Current (430 Ω)	0 mA to 120 ma	2 % \pm 0.3 mA
Resistance	0 Ω to 100 Ω	0.1 % \pm 0.10 Ω
(Shorts & Grounds)	100 Ω to 4 k Ω	0.3 % \pm 0.10 Ω
	4 k Ω to 100 M Ω	3 %
Leakage Stress	2 k Ω to 100 M Ω	3 %
Opens	0 ft to 3000 ft	1 % \pm 5 ft
	3 kft to 50 kft	3 %
	50 kft to 80 kft	5 %
Splits	0 kft to 50 kft	10 % DTE \pm 50 ft ¹

¹Dist. to End; Dist. to Split >50 ft; Split pairs must be same length \pm 5 %.

Operational Specifications: Basic 990DSL (continued)

Function	Range	Accuracy
RFL		
Fault Resistance (Rf)	0 M Ω to 30 M Ω	-
Loop resistance	0 Ω to 4000 Ω	-
Resistance to Fault	0 Ω to 100 Ω	0.1 % RTS ¹ \pm 0.10 Ω
(@ Rf = 100 k Ω)	100 Ω to 4 k Ω	0.3 % RTS ¹ \pm 0.10 Ω
K-Test Res. To Fault	0 Ω to 4 k Ω	1 % RTS ¹ \pm 1 Ω
Load Coils		
Count	0 to 6	\pm 1
Distance to First	0 to 12,000 ft	10 % \pm 500 ft
Tracing Tone		
Frequency	577.5 Hz	0.1 %
Level	>3.5 V peak-to-peak	10 %
VF Noise		
Impedance	600 Ω , Bridged	1 %
Filters	C, CN, 3 k, 15 k, Pso.	-
Metallic Noise	0 dBrn to 10 dBrn	\pm 2 dB
	10 dBrn to 100 dBrn	\pm 1 dB
Power Influence	40 dBrn to 120 dBrn	\pm 2 dB
Power Harmonics	-60 dBm to +20 dBm (50 Hz to 3 kHz)	\pm 2 dB
VF Loss		
Signal Level	-40 dBm to +10 dBm	\pm 0.5 dB (Dry Line)
		\pm 1.0 dB (Dial-up Single Tone)
		\pm 2.0 dB (Dial-up SmartTone)
Frequency	100 Hz to 20 kHz	0.1 % \pm 2 Hz

¹RTS = Resistance to Strap

Operational Specifications: Basic 990DSL (continued)

Function	Range	Accuracy
VF Long. Balance	0 dB to 70 dB	±2 dB
Disturbing Frequency	200 Hz to 2500 Hz	0.1 %
Impedance	600 Ω	1 %
Send VF Tone		
Frequency	100 Hz to 20 kHz	0.1 %
Amplitude (Settable)	-20 dBm to +3 dBm	±0.5 dB (1 dB increment)
Impedance	600 Ω, 900 Ω	1 %

Operational Specifications: 990DSL Wideband Option

Function	Range	Accuracy
WB Noise/Level		
Impedance	100 Ω, 135 Ω, Bridged	1 %
Filters	E, F, G, None	-
Frequency	10 kHz to 1200 kHz	0.1 % ±508.63 Hz
Amplitude	-50 dBm to +3 dBm	±1 dB @ 135 Ω ³
	-90 dBm to -50 dBm	±3 dB @ 135 Ω ³
WB Loss		
Impedance	135 Ω	1 %
Frequency	10 kHz to 1200 kHz	0.1 % ±508.63 Hz
Magnitude	0 dB to 50 dB	±1 dB ³
	50 dB to 70 dB	±2 dB ³
HDSL2/4 Loop Atten.	0 to 70 dB	±2 dB

³ Send frequency = Integral multiple of 508.626 Hz

Operational Specifications: Wideband Option (continued)

Function	Range	Accuracy
WB Long. Balance	0 dB to 70 dB	±5 dB
Disturbing Frequency	20 kHz to 1104 kHz	0.1 %
Impedance	100 Ω, 135 Ω	1 %
Filters	E, F, G, None	-
Send WB Tone		
Frequency	10 kHz to 1200 kHz	0.1 % ±508.63 Hz
Amplitude (fixed)	0.0 dBm	±0.5 dB
Impedance	100 Ω, 135 Ω	1 %
WB Impulse Noise		
Impedance	100 Ω, 135 Ω, Bridged	1 %
Filters	E, F, G, None	-
Test Time	1 to 1440 min. (24 hrs.)	1 %
Impulse Counter	0 to 9999	-
Counter Threshold	-40 dBm to 0 dBm	±1 dB
ADSL Auto-Test		
Impedance	100 Ω	1 %
Noise Filter	E, F, G, None	-
ADSL Standard	ANSI Full, G. Lite	-
Data Rate Prediction:		
Resolution	32 kb/s	-
Downstream Rate	0 kb/s to 8192 kb/s	±96 kb/s
Upstream Rate	0 kb/s to 1024 kb/s	±64 kb/s

Operational Specifications: 990DSL TDR Option

Function	Range	Accuracy
Launch Pulse		
Impedance	100 Ω	1 %
Pulse-width	20 ns, 100 ns, 500 ns, 1000 ns, 2500 ns, 5000 ns	10 % \pm 5 ns
VOP Selection		
	0.300 to 0.999	-
Range		
	30,000 ft	-
(VOP = 0.64, 19 Ga.)		
Range Selection	10 ft to 48 kft (Auto.)	-
Horizontal Resolution	0.5 ft to 156 ft	-
Distance to Reflection	0 ft to 30,000 ft	1 % \pm VOP uncertainty
Vertical Gain		
	80 dB	2 dB
Power Filter		
	5 kHz Highpass	-
Averaging Filter		
	4 waveform average	-
Input Protection		
	\pm 400 V peak	-

Appendix B ***Replacement Parts and Accessories***

Introduction

Appendix B provides information about the replacement parts and optional accessories that you can obtain for the 990DSL CopperPro Loop Tester. To order accessories, call one of the following numbers:

USA: 1-888-993-5853

Canada: 1-800-363-5853

Europe: +31-402-675-200

Japan: +81-3-3434-0181

Singapore: +65-738-5655

Anywhere in the world: +1-425-446-4519

Replacement Parts

Table B-1 lists replacement parts that you can purchase for the CopperPro. When you place an order, you will need to supply the order number for the item. Refer to Figure B-1 for an illustration of the replacement parts listed in this table. Use the Item Number to locate the part.

Table B-1. Replacement Parts for the CopperPro Loop Tester

Item Number	Description	Order Number
①	Holster	PN 665950
②	Battery Door	PN 938357
③	Test Lead Set	Contact Fluke Networks Customer Service
④	Shoulder Strap	PN 1576950
⑤	Soft Case	PN 2003588
⑥	RS-232 Cable	PN 944806
Not Shown	990DSL CopperPro Users Guide	PN 1554870
Not Shown	990-Printer Cable	PN 943738

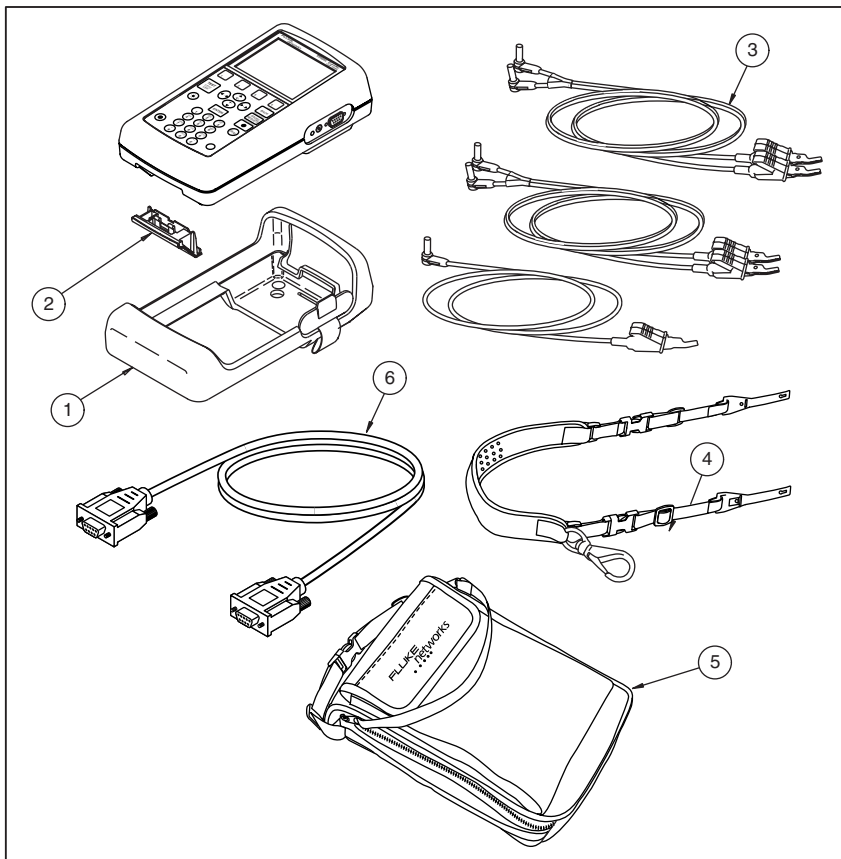

acy76f.eps

Figure B-1. Replacement Parts

Table B-2 lists the optional accessories that are available for the CopperPro. When you place an order, supply the order number for the item. Use the number in the Item Number column to locate the listed accessories.

Table B-2. Optional Accessories for the CopperPro Loop Tester

Item Number	Description	Order Number
①	Deluxe Soft Case	990-CASE
②	NiMH Extra Battery Pack	BP7235
③	External Battery Charger NiMH INTL with Power Supply	BC7210 INTL
④	External Battery Charger NiMH 120V with Power Supply	BC7210 120
⑤	Test Lead Set, Spike + Bed of Nails Contacts	990TL-SB
⑥	Test Lead Set, Spike + No Bed of Nails Contacts	990TL-S
⑦	Test Lead Set, No Spike + Bed of Nails Contacts	990TL-B
⑧	Test Lead Set, No Spike + No Bed of Nails Contacts	990TL-N
⑨	Test Lead Set (International)	(TBD)
⑩	12V Vehicle Battery Charger/Adapter	BE720
Not Shown	990DSL Serial Graphics Printer	990-PRINTER
Not Shown	990 Serial Printer Cable	PN 943738

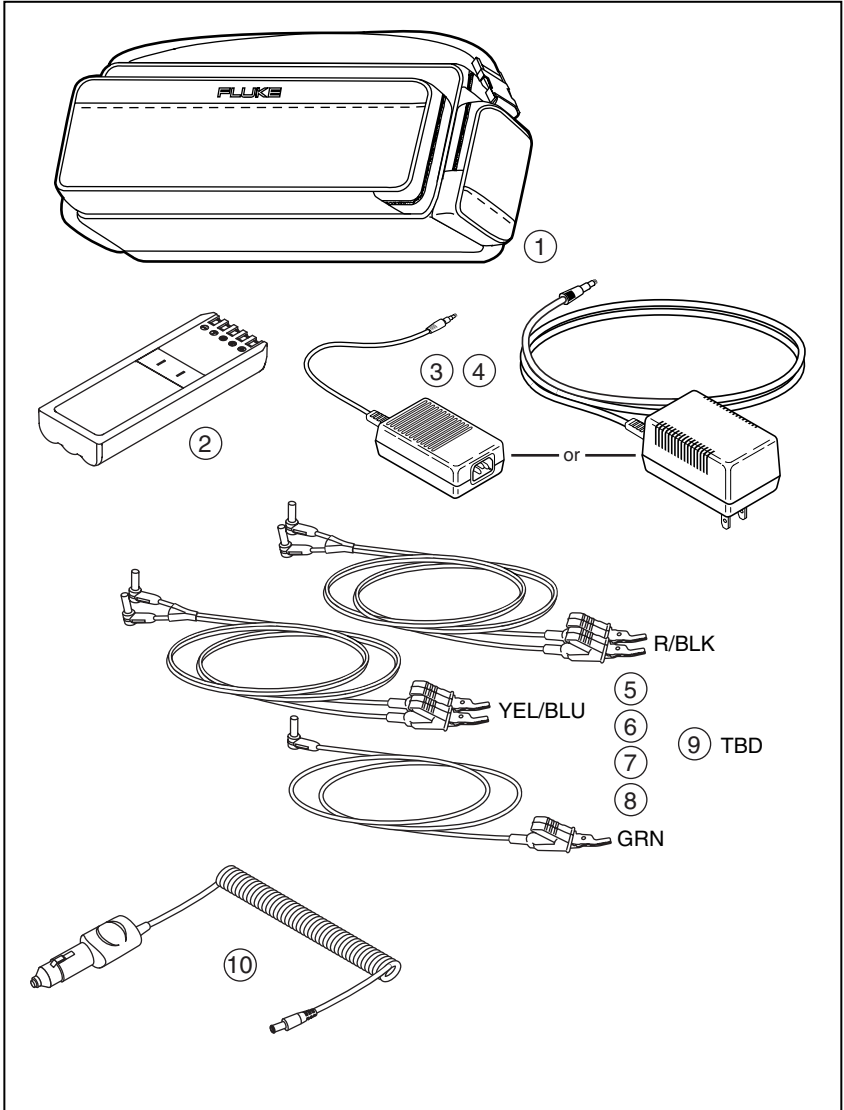

Figure B-2. Optional Accessories

acy77f.eps

—A—

- AC power, connecting to, 2-8
- Adjusted Opens test, 4-17
- automobile battery, connecting to, 2-8
- Auto-Tests, 3-4

—B—

- backlight, turning on and off, 3-21
- battery, 2-10
 - checking capacity, 2-10
 - conserving power, 3-12
 - deep discharge, 2-13
 - discharging, 2-13

—C—

- calibrating the CopperPro, 3-20
- charging status LED, 2-7
- Compare Recall and Pair 1 test, 6-17
- comparing traces, 6-17
- configuring the CopperPro, 3-10
- connector panel, 2-6
- conserving battery power, 3-12
- Contin. DCV softkey, 4-11
- Continuous Voltage test, 4-11
- CopperPro
 - AC power, connecting to, 2-8
 - automobile battery, connecting to, 2-8
 - Auto-Tests, 3-4
 - backlight, turning on and off, 3-21
 - battery, 2-10
 - calibrating, 3-20
 - configuring the tester, 3-10
 - connector panel, 2-6
 - date/time, setting, 3-11
 - dial set operation, 3-23

- features, A-2
- front panel, 2-2
- individual tests, 3-4
- keys, 2-3
- language of displays, changing, 3-13
- LCD, 2-3
- Main menu, 3-3
- measurement units, changing, 3-13
- menus, 3-3
- PC, connecting to, 2-9
- printer, connecting to, 2-9, 7-11
- printing, 3-24
- RS-232 port, 2-6
- self-tests, running, 3-24
- serial number, storing, 3-16
- serial port, configuring, 3-17
- setup menus, accessing, 3-4
- software version, displaying, 3-2, 3-22
- speaker, adjusting volume of, 3-22
- specifications, A-3
- toolbox tests, 3-4
- turning on, 3-2
- crosstalk test, 6-16

—D—

- date/time, setting, 3-11
- DATU tests, 4-65
- DC power jack, 2-6
- dial set, 3-23
- Dial-Up tests, 4-53
- discharging the battery, 2-13

—E—

- editing the setup for a test, 3-7

—F—

Facility Cable No., 3-7
factory default values, restoring, 4-3
fault resistances, converting to distance,
4-14
features of CopperPro, A-2
function keys, 2-3

—G—

ground test lead, 2-6

—H—

header for reports, creating, 3-17

—I—

Instrument Pair No., 3-7
intermittent faults, finding, 6-15

—K—

keys, descriptions of, 2-3

—L—

language of displays, changing, 3-13
LCD

- backlight, turning on and off, 3-21
- contrast, adjusting, 3-21
- description of, 2-3

Leakage Stress test, 4-38
LED charging status indicator, 2-7, 2-12
length and gauge information, storing,
4-27

Load Coils test, 4-35
Loop Current and Ground Ohms test, 4-51
Loop Current test, 4-51
Loop Devices test, 4-37
low-power mode, 3-12

—M—

Main menu, 3-3
menus, 3-3

—O—

Ohms-to-Distance measurement, 4-14
On/Off key, 3-2

Opens test, 4-15

—P—

Pair 1 Monitor test, 6-15
Pair 1 test, 6-12
Pair 1 to 2 Crosstalk test, 6-16
Pair 1/Pair 2 Compare test, 6-13
Pair 1/Pair 2 Difference test, 6-14
Pair/Terminal No., 3-7
PC, connecting to, 2-9
POTS self-test, running, 3-24
POTS testing

- Adjusted Opens test, 4-17
- Auto-Test, 4-2
- Dial-Up tests, 4-53
- individual tests, 4-8
- Leakage Stress test, 4-38
- Load Coils test, 4-35
- Loop Devices test, 4-37
- Opens test, 4-15
- RFL test, 4-22
- Send VF Tone test, 4-48
- Shorts & Grounds test, 4-12
- Smart-Pro tests, 4-61
- Splits test, 4-19
- toolbox tests, 4-8
- Tracing Tone test, 4-40
- VF Longitudinal Balance test, 4-47
- VF Loss test, 4-44
- VF Noise test, 4-41
- Voltage test, 4-9, 4-46

power-down mode, 3-12
printer, connecting to, 2-9, 7-11
printing, 3-24

—R—

reflections, 6-4, 6-20
report header, 3-17
Resistance Fault Location (RFL) test,
4-22
RFL test, 4-22
ring test lead, 2-6
RS-232 port, 2-6, 3-17

—S—

SASS tests, 4-53, 4-63, 4-64
self-tests, running, 3-24
Send VF Tone test, 4-48
Send WB Tone test, 5-26
serial number, storing, 3-16
serial port, configuring, 3-17
setup menus, 3-4
Setups softkey, 3-4
Shorts & Grounds test, 4-12
Smart-Pro test, 4-53
Smart-Pro tests, 4-61
softkeys, 2-3
software updates, 8-1
software version, 3-22
sound, adjusting, 3-22
speaker, adjusting volume of, 3-22
specifications, A-3
Splits test, 4-19
system information, displaying, 3-22

—T—

TDR self-test, running, 3-24
TDR testing, 6-3
 Auto-Test, 6-4
 Compare Recall and Pair 1 test, 6-17
 displaying and deleting traces, 6-17
 Pair 1 Monitor test, 6-15
 Pair 1 test, 6-12
 Pair 1 to 2 Crosstalk test, 6-16
 Pair 1/Pair 2 Compare test, 6-13
 Pair 1/Pair 2 Difference test, 6-14
 starting and stopping, 6-12
 toolbox tests, 6-11
telephone list, creating, 3-14
Terminated VF tests, 4-67
tests, individual, 3-4
Time Domain Reflectometer. *See* TDR
 testing
timers, 3-12
tip test lead, 2-6
toolbox tests, 3-4
traces

 comparing, 6-17
 deleting, 6-17
 displaying, 6-17
 saving, 6-12
Tracing Tone test, 4-40
turning on the tester, 3-2

—U—

updating the tester, 8-1
uploading results to a PC, 3-24

—V—

Velocity of propagation. *See* Vop
VF Longitudinal Balance test, 4-47
VF Loss test, 4-44, 4-46
VF Noise test, 4-41
Voltage test, 4-9
Vop, 6-3

—W—

WB Impulse Noise, 5-32
WB Longitudinal Balance test, 5-24
WB Loss test, 5-22
WB Noise/Level test, 5-19
WB self-test, running, 3-24

—X—

XDSL testing
 WB Impulse Noise test, 5-32
 WB Longitudinal Balance test, 5-24
 WB Loss test, 5-22
 WB Noise/Level test, 5-19
 WB Tone test, 5-26
 XDSL toolbox, 5-17

—Z—

Zero Leads utility, 3-20



205 Westwood Ave
Long Branch, NJ 07740
1-877-742-TEST (8378)
Fax: (732) 222-7088
salesteam@Tequipment.NET