



User's manual FLIR Kx3 series



Call Us 1.877.571.7901





User's manual FLIR Kx3 series



Table of contents

1	Legal disclaimer	1
1.1	Legal disclaimer	1
1.2	Usage statistics	1
1.3	Changes to registry	1
1.4	U.S. Government Regulations.....	1
1.5	Copyright	1
1.6	Quality assurance	1
1.7	Patents.....	1
1.8	EULA Terms	1
2	Safety information	2
3	Notice to user	6
3.1	User-to-user forums	6
3.2	Disposal of electronic waste	6
3.3	Training	6
3.4	Documentation updates	6
3.5	Important note about this manual.....	6
3.6	Note about authoritative versions.....	7
4	Customer help	8
4.1	General	8
4.2	Submitting a question	8
4.3	Downloads	9
5	Important information about FLIR Kx3 series service	10
6	Quick start guide	11
6.1	Quick start guide, FLIR K33	11
6.2	Quick start guide, FLIR K53	11
7	List of accessories and services	12
8	System configuration overview	13
8.1	Figure	13
8.2	Explanation	13
9	System parts	15
9.1	Camera parts.....	15
9.1.1	Figure.....	15
9.1.2	Explanation.....	15
9.2	Lanyard strap and retractable lanyard.....	16
9.3	Handle strap and retractable lanyard.....	16
9.4	Neck strap.....	17
10	Screen elements	18
10.1	Figure	18
10.2	Explanation	18
10.3	Battery condition indicator	18
11	Operation	19
11.1	Removing the battery.....	19
11.1.1	Charging the battery	19
11.2	Turning on and turning off the camera.....	20
11.3	Basic mode	20
11.3.1	Automatic temperature range selection	21
11.4	Saving an image (FLIR K53).....	21
11.4.1	General.....	21
11.4.2	Figure.....	22

Table of contents

11.4.3	Procedure	22
11.5	Recording a video clip (FLIR K53)	22
11.5.1	General.....	22
11.5.2	Figure.....	22
11.5.3	Procedure	22
11.6	Continuous video recording (FLIR K53)	23
11.6.1	General.....	23
11.7	Freezing the image.....	23
11.7.1	General.....	23
11.7.2	Figure.....	23
11.7.3	Procedure	23
11.8	Changing the temperature unit.....	24
11.9	Connecting the camera to a computer	24
11.9.1	General.....	24
11.9.2	Procedure	25
11.10	Changing settings in FLIR Tools	26
11.10.1	The <i>General settings</i> tab.....	26
11.10.2	The <i>User interface</i> tab	27
12	In-truck charger (optional accessory)	29
12.1	Introduction	29
12.2	Parts and functions	30
12.3	Choosing a suitable position.....	30
12.4	Recommended cable area and fuse.....	31
12.5	Mounting instructions.....	31
12.6	Charging the camera	31
12.7	Charging a battery separately	31
12.8	Cleaning	32
12.9	Customer support	32
13	Technical data.....	33
13.1	Online field-of-view calculator	33
13.2	Note about technical data	33
13.3	Note about authoritative versions.....	33
13.4	FLIR K33	34
13.5	FLIR K53	38
13.6	In-truck charger	42
14	Mechanical drawings	44
15	CE Declaration of conformity	48
16	Cleaning, decontamination and disinfection	50
16.1	Cleaning	50
16.1.1	Camera housing, cables, and other items	50
16.1.2	Infrared lens.....	50
16.2	Decontamination and disinfection	51
17	Maintenance, inspection, and service	52
17.1	Maintenance.....	52
17.2	Inspection	52
17.3	Service.....	52
18	Storage conditions	53
19	About FLIR Systems	54
19.1	More than just an infrared camera	55

Table of contents

19.2	Sharing our knowledge	56
19.3	Supporting our customers.....	56
20	History of infrared technology.....	57

1.1 Legal disclaimer

All products manufactured by FLIR Systems are warranted against defective materials and workmanship for a period of one (1) year from the delivery date of the original purchase, provided such products have been under normal storage, use and service, and in accordance with FLIR Systems instruction.

Uncooled handheld infrared cameras manufactured by FLIR Systems are warranted against defective materials and workmanship for a period of two (2) years from the delivery date of the original purchase, provided such products have been under normal storage, use and service, and in accordance with FLIR Systems instruction, and provided that the camera has been registered within 60 days of original purchase.

Detectors for uncooled handheld infrared cameras manufactured by FLIR Systems are warranted against defective materials and workmanship for a period of ten (10) years from the delivery date of the original purchase, provided such products have been under normal storage, use and service, and in accordance with FLIR Systems instruction, and provided that the camera has been registered within 60 days of original purchase.

Products which are not manufactured by FLIR Systems but included in systems delivered by FLIR Systems to the original purchaser, carry the warranty, if any, of the particular supplier only. FLIR Systems has no responsibility whatsoever for such products.

The warranty extends only to the original purchaser and is not transferable. It is not applicable to any product which has been subjected to misuse, neglect, accident or abnormal conditions of operation. Expendable parts are excluded from the warranty.

In the case of a defect in a product covered by this warranty the product must not be further used in order to prevent additional damage. The purchaser shall promptly report any defect to FLIR Systems or this warranty will not apply.

FLIR Systems will, at its option, repair or replace any such defective product free of charge if, upon inspection, it proves to be defective in material or workmanship and provided that it is returned to FLIR Systems within the said one-year period.

FLIR Systems has no other obligation or liability for defects than those set forth above.

No other warranty is expressed or implied. FLIR Systems specifically disclaims the implied warranties of merchantability and fitness for a particular purpose.

FLIR Systems shall not be liable for any direct, indirect, special, incidental or consequential loss or damage, whether based on contract, tort or any other legal theory.

This warranty shall be governed by Swedish law.

Any dispute, controversy or claim arising out of or in connection with this warranty, shall be finally settled by arbitration in accordance with the Rules of the Arbitration Institute of the Stockholm Chamber of Commerce. The place of arbitration shall be Stockholm. The language to be used in the arbitral proceedings shall be English.

1.2 Usage statistics

FLIR Systems reserves the right to gather anonymous usage statistics to help maintain and improve the quality of our software and services.

1.3 Changes to registry

The registry entry "HKEY_LOCAL_MACHINE\SYSTEM\CurrentControlSet\Control\Lsa\CompatibilityLevel will be automatically changed to level 2 if the FLIR Camera Monitor service detects a FLIR camera connected to the computer with a USB cable. The modification will only be executed if the camera device implements a remote network service that supports network logons.

1.4 U.S. Government Regulations

This product may be subject to U.S. Export Regulations. Please send any inquiries to exportquestions@flir.com.

1.5 Copyright

© 2016, FLIR Systems, Inc. All rights reserved worldwide. No parts of the software including source code may be reproduced, transmitted, transcribed or translated into any language or computer language in any form or by any means, electronic, magnetic, optical, manual or otherwise, without the prior written permission of FLIR Systems.

The documentation must not, in whole or part, be copied, photocopied, reproduced, translated or transmitted to any electronic medium or machine readable form without prior consent, in writing, from FLIR Systems.

Names and marks appearing on the products herein are either registered trademarks or trademarks of FLIR Systems and/or its subsidiaries. All other trademarks, trade names or company names referenced herein are used for identification only and are the property of their respective owners.

1.6 Quality assurance

The Quality Management System under which these products are developed and manufactured has been certified in accordance with the ISO 9001 standard.

FLIR Systems is committed to a policy of continuous development; therefore we reserve the right to make changes and improvements on any of the products without prior notice.

1.7 Patents

000439161; 000653423; 000726344; 000859020; 001707738; 001707746; 001707787; 001776519; 001954074; 002021543; 002021543-0002; 002056180; 002249953; 002531178; 002816785; 002816793; 011200326; 014347553; 057692; 061608; 07002405; 100414275; 101796816; 101796817; 101796818; 102334141; 1062100; 11063060001; 11517895; 1226865; 12300216; 12300224; 1285545; 1299699; 1325808; 1336775; 1391114; 1402918; 1404291; 1411581; 1415075; 1421497; 1458284; 1678485; 1732314; 17399650; 1880950; 1886650; 2007301511414; 2007303395047; 2008301285812; 2009301900619; 20100603057; 2010301761271; 2010301761303; 2010301761572; 2010305959313; 2011304423549; 2012304717443; 2012306207318; 2013302676195; 2015202354035; 2015304259171; 204465713; 204967995; 2106017; 2107799; 2115696; 2172004; 2315433; 2381417; 2794760001; 3006596; 3006597; 303302011; 4358936; 483782; 484155; 4889913; 4937897; 4995790001; 5177595; 540838; 579475; 584755; 599392; 60122153; 6020040116815; 602006006500.0; 6020080347796; 6020110003453; 615113; 615116; 664580; 664581; 665004; 665440; 67023029; 6707044; 677298; 68657; 69036179; 70022216; 70028915; 70028923; 70057990; 7034300; 710424; 7110035; 7154093; 7157705; 718801; 7238005; 7237946; 7312822; 7332716; 7396823; 734803; 7544944; 7606484; 7634157; 7667198; 7809258; 7826738; 8018649; 8153971; 8212210; 8289372; 8340414; 8354639; 8384783; 8520970; 8565547; 8595889; 8592622; 8654239; 8680468; 8803093; 8823803; 8853631; 8933403; 9171361; 9191583; 9279728; 9280812; 9338352; 9423940; 9471970; 9595087; D549758.

1.8 EULA Terms

- You have acquired a device ("INFRARED CAMERA") that includes software licensed by FLIR Systems AB from Microsoft Licensing, GP or its affiliates ("MS"). Those installed software products of MS origin, as well as associated media, printed materials, and "online" or electronic documentation ("SOFTWARE") are protected by international intellectual property laws and treaties. The SOFTWARE is licensed, not sold. All rights reserved.
- IF YOU DO NOT AGREE TO THIS END USER LICENSE AGREEMENT ("EULA"), DO NOT USE THE DEVICE OR COPY THE SOFTWARE. INSTEAD, PROMPTLY CONTACT FLIR Systems AB FOR INSTRUCTIONS ON RETURN OF THE UNUSED DEVICE(S) FOR A REFUND. **ANY USE OF THE SOFTWARE, INCLUDING BUT NOT LIMITED TO USE ON THE DEVICE, WILL CONSTITUTE YOUR AGREEMENT TO THIS EULA (OR RATIFICATION OF ANY PREVIOUS CONSENT).**
- **GRANT OF SOFTWARE LICENSE.** This EULA grants you the following license:
 - You may use the SOFTWARE only on the DEVICE.
 - **NOT FAULT TOLERANT.** THE SOFTWARE IS NOT FAULT TOLERANT. FLIR Systems AB HAS INDEPENDENTLY DETERMINED HOW TO USE THE SOFTWARE IN THE DEVICE, AND MS HAS RELIED UPON FLIR Systems AB TO CONDUCT SUFFICIENT TESTING TO DETERMINE THAT THE SOFTWARE IS SUITABLE FOR SUCH USE.
 - **NO WARRANTIES FOR THE SOFTWARE.** THE SOFTWARE IS PROVIDED "AS IS" and with all faults. THE ENTIRE RISK AS TO SATISFACTORY QUALITY, PERFORMANCE, ACCURACY, AND EFFORT (INCLUDING LACK OF NEGLIGENCE) IS WITH YOU. ALSO, THERE IS NO WARRANTY AGAINST INTERFERENCE WITH YOUR ENJOYMENT OF THE SOFTWARE OR AGAINST INFRINGEMENT. **IF YOU HAVE RECEIVED ANY WARRANTIES REGARDING THE DEVICE OR THE SOFTWARE, THOSE WARRANTIES DO NOT ORIGINATE FROM, AND ARE NOT BINDING ON, MS.**
 - No Liability for Certain Damages. **EXCEPT AS PROHIBITED BY LAW, MS SHALL HAVE NO LIABILITY FOR ANY INDIRECT, SPECIAL, CONSEQUENTIAL OR INCIDENTAL DAMAGES ARISING FROM OR IN CONNECTION WITH THE USE OR PERFORMANCE OF THE SOFTWARE. THIS LIMITATION SHALL APPLY EVEN IF ANY REMEDY FAILS OF ITS ESSENTIAL PURPOSE. IN NO EVENT SHALL MS BE LIABLE FOR ANY AMOUNT IN EXCESS OF U.S. TWO HUNDRED FIFTY DOLLARS (U.S.\$250.00).**
 - **Limitations on Reverse Engineering, Decompilation, and Disassembly.** You may not reverse engineer, decompile, or disassemble the SOFTWARE, except and only to the extent that such activity is expressly permitted by applicable law notwithstanding this limitation.
 - **SOFTWARE TRANSFER ALLOWED BUT WITH RESTRICTIONS.** You may permanently transfer rights under this EULA only as part of a permanent sale or transfer of the Device, and only if the recipient agrees to this EULA. If the SOFTWARE is an upgrade, any transfer must also include all prior versions of the SOFTWARE.
 - **EXPORT RESTRICTIONS.** You acknowledge that SOFTWARE is subject to U.S. export jurisdiction. You agree to comply with all applicable international and national laws that apply to the SOFTWARE, including the U.S. Export Administration Regulations, as well as end-user, end-use and destination restrictions issued by U.S. and other governments. For additional information see <http://www.micro-soft.com/exporting/>.

Safety information



WARNING

Applicability: Cameras with one or more batteries.

Do not disassemble or do a modification to the battery. The battery contains safety and protection devices which, if damage occurs, can cause the battery to become hot, or cause an explosion or an ignition.



WARNING

Applicability: Cameras with one or more batteries.

If there is a leak from the battery and you get the fluid in your eyes, do not rub your eyes. Flush well with water and immediately get medical care. The battery fluid can cause injury to your eyes if you do not do this.



WARNING

Applicability: Cameras with one or more batteries.

Do not continue to charge the battery if it does not become charged in the specified charging time. If you continue to charge the battery, it can become hot and cause an explosion or ignition. Injury to persons can occur.



WARNING

Applicability: Cameras with one or more batteries.

Only use the correct equipment to remove the electrical power from the battery. If you do not use the correct equipment, you can decrease the performance or the life cycle of the battery. If you do not use the correct equipment, an incorrect flow of current to the battery can occur. This can cause the battery to become hot, or cause an explosion. Injury to persons can occur.



WARNING

Make sure that you read all applicable MSDS (Material Safety Data Sheets) and warning labels on containers before you use a liquid. The liquids can be dangerous. Injury to persons can occur.



CAUTION

Do not point the infrared camera (with or without the lens cover) at strong energy sources, for example, devices that cause laser radiation, or the sun. This can have an unwanted effect on the accuracy of the camera. It can also cause damage to the detector in the camera.



CAUTION

Applicability: Cameras with one or more batteries.

Do not attach the batteries directly to a car's cigarette lighter socket, unless FLIR Systems supplies a specific adapter to connect the batteries to a cigarette lighter socket. Damage to the batteries can occur.



CAUTION

Applicability: Cameras with one or more batteries.

Do not connect the positive terminal and the negative terminal of the battery to each other with a metal object (such as wire). Damage to the batteries can occur.



CAUTION

Applicability: Cameras with one or more batteries.

Do not get water or salt water on the battery, or permit the battery to become wet. Damage to the batteries can occur.

 **CAUTION**

Applicability: Cameras with one or more batteries.

Do not make holes in the battery with objects. Damage to the battery can occur.

 **CAUTION**

Applicability: Cameras with one or more batteries.

Do not hit the battery with a hammer. Damage to the battery can occur.

 **CAUTION**

Applicability: Cameras with one or more batteries.

Do not put your foot on the battery, hit it or cause shocks to it. Damage to the battery can occur.

 **CAUTION**

Applicability: Cameras with one or more batteries.

Do not put the batteries in or near a fire, or into direct sunlight. When the battery becomes hot, the built-in safety equipment becomes energized and can stop the battery charging procedure. If the battery becomes hot, damage can occur to the safety equipment and this can cause more heat, damage or ignition of the battery.

 **CAUTION**

Applicability: Cameras with one or more batteries.

Do not put the battery on a fire or increase the temperature of the battery with heat. Damage to the battery and injury to persons can occur.

 **CAUTION**

Applicability: Cameras with one or more batteries.

Do not put the battery on or near fires, stoves, or other high-temperature locations. Damage to the battery and injury to persons can occur.

 **CAUTION**

Applicability: Cameras with one or more batteries.

Do not solder directly onto the battery. Damage to the battery can occur.

 **CAUTION**

Applicability: Cameras with one or more batteries.

Do not use the battery if, when you use, charge, or put the battery in storage, there is an unusual smell from the battery, the battery feels hot, changes color, changes shape, or is in an unusual condition. Speak with your sales office if one or more of these problems occurs. Damage to the battery and injury to persons can occur.

 **CAUTION**

Applicability: Cameras with one or more batteries.

Only use a specified battery charger when you charge the battery. Damage to the battery can occur if you do not do this.

 **CAUTION**

Applicability: Cameras with one or more batteries.

Only use a specified battery for the camera. Damage to the camera and the battery can occur if you do not do this.

 **CAUTION**

Applicability: Cameras with one or more batteries.

The temperature range through which you can charge the battery is 0°C to +45°C (+32°F to +113°F). If you charge the battery at temperatures out of this range, it can cause the battery to become hot or to break. It can also decrease the performance or the life cycle of the battery.

 **CAUTION**

Applicability: Cameras with one or more batteries.

The temperature range through which you can remove the electrical power from the battery is -15°C to +50°C (+5°F to +122°F), unless other information is specified in the user documentation or technical data. If you operate the battery out of this temperature range, it can decrease the performance or the life cycle of the battery.

 **CAUTION**

Applicability: Cameras with one or more batteries.

When the battery is worn, apply insulation to the terminals with adhesive tape or equivalent materials before you discard it. Damage to the battery and injury to persons can occur if you do not do this.

 **CAUTION**

Applicability: Cameras with one or more batteries.

Remove any water or moisture on the battery before you install it. Damage to the battery can occur if you do not do this.

 **CAUTION**

Do not apply solvents or equivalent liquids to the camera, the cables, or other items. Damage to the battery and injury to persons can occur.

 **CAUTION**

Be careful when you clean the infrared lens. The lens has an anti-reflective coating which is easily damaged. Damage to the infrared lens can occur.

 **CAUTION**

Do not use too much force to clean the infrared lens. This can cause damage to the anti-reflective coating.

Note The encapsulation rating is only applicable when all the openings on the camera are sealed with their correct covers, hatches, or caps. This includes the compartments for data storage, batteries, and connectors.

 **CAUTION**

Do not change the standard fire-fighting procedures when you use a FLIR K series camera. The FLIR K series camera is not a replacement technology.

**CAUTION**

Do not use the FLIR K series camera without the correct training. If the persons that operate the camera do not have the correct training, an incorrect analysis of the infrared images can occur. Thus, incorrect decisions during the firefighting can be made.

The training must include:

- How a thermal camera operates and its limits
- How to interpret an image
- How to work safely with the camera.

3.1 User-to-user forums

Exchange ideas, problems, and infrared solutions with fellow thermographers around the world in our user-to-user forums. To go to the forums, visit:

<http://forum.infraredtraining.com/>

3.2 Disposal of electronic waste



As with most electronic products, this equipment must be disposed of in an environmentally friendly way, and in accordance with existing regulations for electronic waste.

Please contact your FLIR Systems representative for more details.

3.3 Training

To read about infrared training, visit:

- <http://www.infraredtraining.com>
- <http://www.irtraining.com>
- <http://www.irtraining.eu>

3.4 Documentation updates

Our manuals are updated several times per year, and we also issue product-critical notifications of changes on a regular basis.

To access the latest manuals, translations of manuals, and notifications, go to the Download tab at:

<http://support.flir.com>

It only takes a few minutes to register online. In the download area you will also find the latest releases of manuals for our other products, as well as manuals for our historical and obsolete products.

3.5 Important note about this manual

FLIR Systems issues generic manuals that cover several cameras within a model line.

This means that this manual may contain descriptions and explanations that do not apply to your particular camera model.

3.6 Note about authoritative versions

The authoritative version of this publication is English. In the event of divergences due to translation errors, the English text has precedence.

Any late changes are first implemented in English.

FLIR Customer Support Center

Home
Answers
Ask a Question
Product Registration
Downloads
My Stuff
Service

FLIR Customer support

Get the most out of your FLIR products

Get Support for Your FLIR Products

Welcome to the FLIR Customer Support Center. This portal will help you as a FLIR customer to get the most out of your FLIR products. The portal gives you access to:

- The FLIR Knowledgebase
- Ask our support team (requires registration)
- Software and documentation (requires registration)
- FLIR service contacts

Find Answers

We store all resolved problems in our solution database. Search by product, category, keywords, or phrases.

Search by Keyword

[Search All Answers](#)

[See All Popular Answers](#)

To find a datasheet for a current product, click on a picture.
To find a datasheet for a legacy product, click [here](#).

FLIR Ex



FLIR Exx



FLIR Kxx



FLIR T4xx



FLIR T6xx



FLIR G3xx



ThermaCAM™
GasFindIR



FLIR GF3xx



FLIR AX



FLIR Ax5



FLIR A3xx



[More...](#)

Product catalog

Please right-click the links below and select Save Target As... to save the file.



US Letter (28 Mb)

A4 (27.4 Mb)

Accessories



Important legal disclaimer, dangers, warnings, and cautions

4.1 General

For customer help, visit:

<http://support.flir.com>

4.2 Submitting a question

To submit a question to the customer help team, you must be a registered user. It only takes a few minutes to register online. If you only want to search the knowledgebase for existing questions and answers, you do not need to be a registered user.

When you want to submit a question, make sure that you have the following information to hand:

- The camera model

- The camera serial number
- The communication protocol, or method, between the camera and your device (for example, SD card reader, HDMI, Ethernet, USB, or FireWire)
- Device type (PC/Mac/iPhone/iPad/Android device, etc.)
- Version of any programs from FLIR Systems
- Full name, publication number, and revision number of the manual

4.3 Downloads

On the customer help site you can also download the following, when applicable for the product:

- Firmware updates for your infrared camera.
- Program updates for your PC/Mac software.
- Freeware and evaluation versions of PC/Mac software.
- User documentation for current, obsolete, and historical products.
- Mechanical drawings (in *.dxf and *.pdf format).
- Cad data models (in *.stp format).
- Application stories.
- Technical datasheets.
- Product catalogs.

Important information about FLIR Kx3 series service

- Contact the service department before shipping the camera. Many problems can be resolved on the phone—if so, the camera does not need to be shipped.
- The camera must be thoroughly cleaned, decontaminated and disinfected before shipping to our service department. No hazardous residues are allowed on cameras. Such residues include—but are not limited to—chemical fire-extinguishing compounds, radioactivity, biohazardous materials, and residues from chemical fires.
- FLIR Systems reserves the right to charge the full cost for the decontamination and disinfection of contaminated cameras that are shipped to our service department.

6.1 Quick start guide, FLIR K33

Follow this procedure:

1. Charge the battery for 4 hours before starting the camera for the first time, or until the blue battery condition LED glows continuously.
2. Push the on/off button to turn on the camera.
3. Aim the camera toward the object of interest.
4. To freeze the image, pull and hold the trigger.
5. To return to the live image, release the trigger.

Note The function of the trigger is configured by a setting in FLIR Tools, see section 11.10.2 *The User interface tab*, page 27.

6.2 Quick start guide, FLIR K53

Follow this procedure:

1. Charge the battery for 4 hours before starting the camera for the first time, or until the blue battery condition LED glows continuously.
2. Push the on/off button to turn on the camera.
3. Aim the camera toward the object of interest.
4. Pull the trigger to save an image.
5. Pull and hold the trigger to record a video clip.
6. Connect the camera to a computer, using the USB cable.
7. Do one of the following:

- Move the image to the computer using a drag-and-drop operation in Microsoft Windows Explorer.

Note Moving an image using a drag-and-drop operation does not delete the image in the camera.

- Move the image to the computer using FLIR Tools. In FLIR Tools you can analyze the images and create PDF reports.

Note The function of the trigger is configured by a setting in FLIR Tools, see section 11.10.2 *The User interface tab*, page 27.

List of accessories and services

Product name	Part no.
Battery charger, incl. power supply with multi plugs (Exx, Kxx)	T198125
Battery Li-ion 3.6 V, 4.4 Ah, 16 Wh	T199368ACC
Carabiner strap	T129915ACC
Cigarette lighter adapter kit, 12 VDC, 1.2 m/3.9 ft.	T198509
In-truck charger	T198322ACC
Lanyard strap	T198416ACC
Li-Ion Battery pack 3.6 V 16 Wh	T198310ACC
Neck strap	T127724ACC
Retractable lanyard	T127722ACC
Transport case Kxx	T198441ACC
Tripod Adapter, Kxx	T198457ACC
USB cable Std A <-> Mini-B	1910423

8.1 Figure

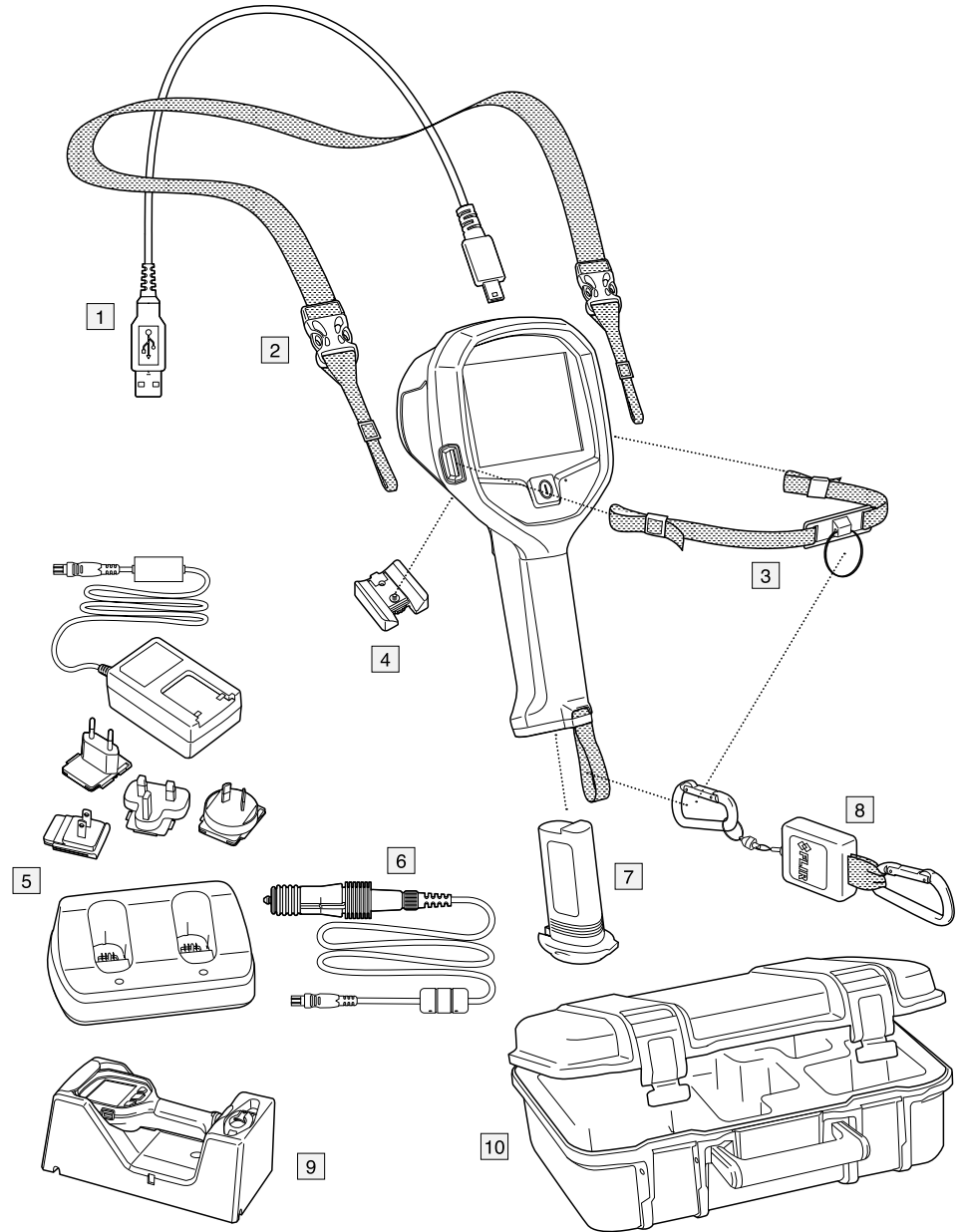

8.2 Explanation

1. FLIR P/N: 1910423, USB cable Std A <-> Mini-B
2. FLIR P/N: T127724ACC, Neck strap¹

1. The inclusion of this item is dependent on model.

3. FLIR P/N: T198416ACC, Strap lanyard²
4. FLIR P/N: T198457ACC, Tripod Adapter, Kxx²
5. FLIR P/N: T198125, Battery charger, incl. power supply with multi plugs
6. FLIR P/N: T198509, Cigarette lighter adapter kit, 12 VDC, 1.2 m/3.9 ft
7. FLIR P/N: T198310ACC, Li-Ion Battery pack 3.6 V 16 Wh
8. FLIR P/N: T127722ACC, Retractable lanyard²
9. FLIR P/N: T198322ACC, In-truck charger
10. FLIR P/N: T198441ACC, Transport case Kxx

2. The inclusion of this item is dependent on model.

9.1 Camera parts

9.1.1 Figure

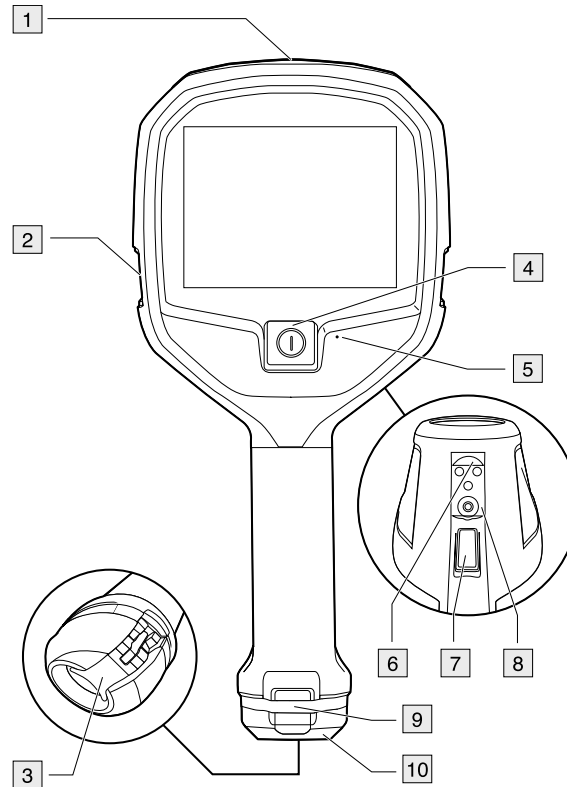

9.1.2 Explanation

1. USB Mini-B connector: Connect to a computer to download images (FLIR K53 only) and change settings using FLIR Tools.
2. Attachment point for the lanyard strap/neck strap (left and right sides).
3. Eccentric latch to secure the battery.
4. On/off button. This button has three functions:
 - Push the on/off button to turn on the camera.
 - Push and hold the on/off button for more than 3 seconds but less than 10 seconds to put the camera into standby mode. The camera then automatically turns off after 6 hours.
 - Push and hold the on/off button for more than 10 seconds to turn off the camera.
5. Pin hole for setting of the temperature unit (°C/°F).
6. Connectors for the in-truck charger.
7. Trigger.
8. Mount for the tripod adapter.
9. Attachment point for the retractable lanyard.
10. Battery.

9.2 Lanyard strap and retractable lanyard

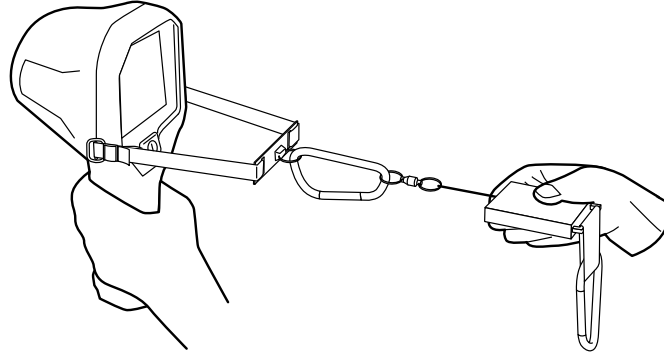

9.3 Handle strap and retractable lanyard

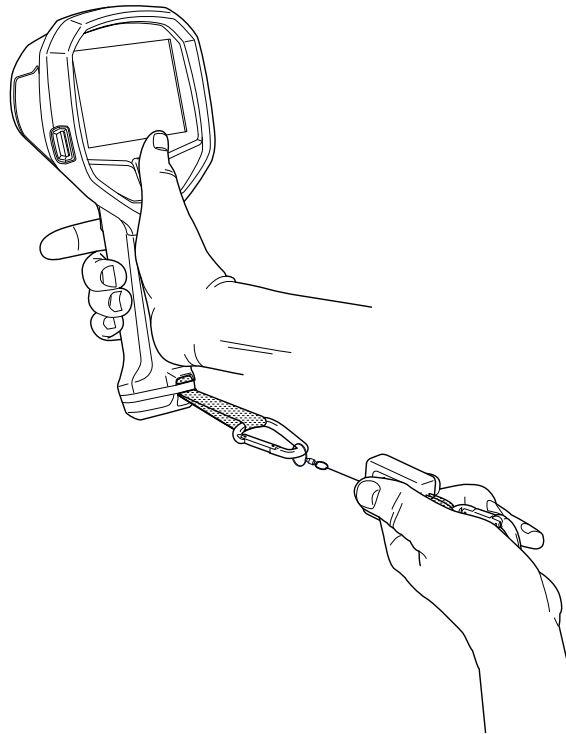

9.4 Neck strap

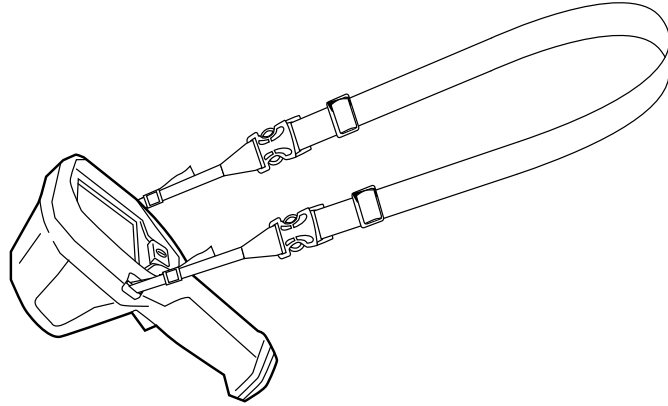

10.1 Figure



10.2 Explanation

1. Low-sensitivity mode indicator. The indicator is displayed when the camera identifies a hot area and automatically switches to the low-sensitivity mode.
2. Overheating indicator. The indicator provides a visual warning to the user that the thermal imager is about to shut down due to internal overheating.
3. Reference bar.
4. Temperature bar.
5. Spotmeter temperature.
6. Battery condition indicator.
7. Spotmeter.

10.3 Battery condition indicator

Battery condition indicator	Explanation
	75% power.
	50% power.
	25% power.
	Flashing indicator. At least 5 minutes of available power remains.

**CAUTION**

Do not use the FLIR K series camera without the correct training. If the persons that operate the camera do not have the correct training, an incorrect analysis of the infrared images can occur. Thus, incorrect decisions during the firefighting can be made.

The training must include:

- How a thermal camera operates and its limits
- How to interpret an image
- How to work safely with the camera.

11.1 Removing the battery

Follow this procedure:

1. Pull the eccentric latch.



2. Pull out the battery from the battery compartment.

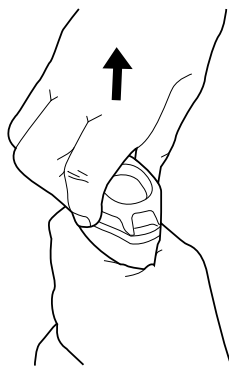

11.1.1 Charging the battery

**WARNING**

Make sure that you install the socket-outlet near the equipment and that it is easy to get access to.

11.1.1.1 General

Charge the battery for 4 hours before starting the camera for the first time, or until the blue battery condition LED glows continuously.

11.1.1.2 Procedure

Follow this procedure:

1. Put the battery in the standalone battery charger.
2. Connect the power supply cable plug to the connector on the standalone battery charger.
3. Connect the power supply mains-electricity plug to a mains socket.
4. Disconnect the power supply cable plug when the blue battery condition LED glows continuously.

11.2 Turning on and turning off the camera

- Push the on/off button to turn on the camera.
- Push and hold the on/off button for more than 3 seconds but less than 10 seconds to put the camera into standby mode. The camera then automatically turns off after 6 hours.
- Push and hold the on/off button for more than 10 seconds to turn off the camera.

11.3 Basic mode

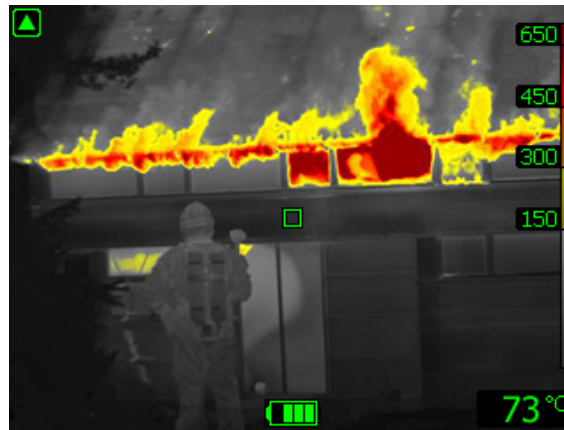

The camera features one camera mode: *Basic mode*. This is a multipurpose mode for the initial fire attack with life-saving operations and control of the fire. The camera automatically switches between the high-sensitivity range and the low-sensitivity range, to maintain an optimal infrared image while at the same time maintaining a safe and consistent heat colorization of the fire scene. This automatic switching of ranges occurs when objects with a temperature above 150°C (302°F) enter the field of view of the camera.

- Automatic range.
- Colorization of heat: +150 to +650°C (+302 to +1202°F).
- High-sensitivity range: -20 to +150°C (-4 to +302°F).
- Low-sensitivity range: 0 to +650°C (+32 to +1202°F).

11.3.1 Automatic temperature range selection

11.3.1.1 General

The automatic temperature range selection is based on a measured area defined by a rectangle covering $(x1, y1) = (15\% \text{ of the width, } 15\% \text{ of the height})$ to $(x2, y2) = (85\% \text{ of the width, } 85\% \text{ of the height})$ of the LCD area. See the figure in section 11.3.1.2.

An automatic change from the high-sensitivity range to the low-sensitivity range occurs if more than 2% of the pixels within the measured area constantly (for more than 1 second) have a temperature above the maximum temperature of the high-sensitivity range.

An automatic change from low-sensitivity range to high-sensitivity range occurs if more than 98% of the pixels within the measured area constantly have, for more than 1 second, a temperature lower than 50°C (122°F) below the maximum temperature of the high-sensitivity range.

11.3.1.2 Figure

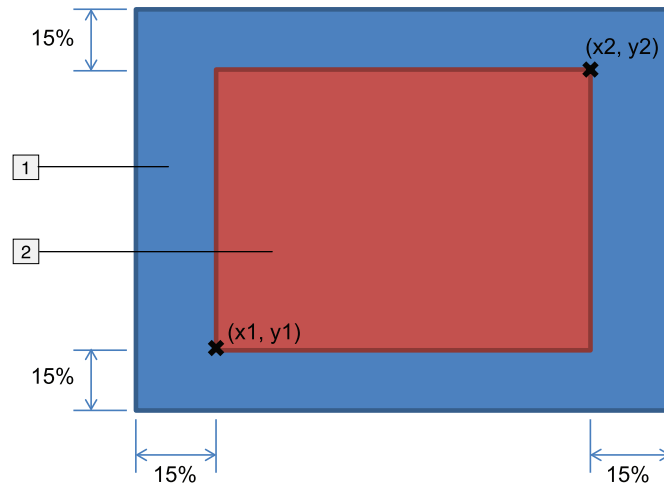

11.3.1.3 Explanation

1. LCD area.
2. Area activating the automatic range change.

11.4 Saving an image (FLIR K53)

11.4.1 General

You can save images to the camera's archive.

Note The maximum number of images that can be saved in the archive is 200. When the number of images exceeds 200, images are deleted on a *first-in, first-out basis*, i.e., the 201st image will delete the 1st image, the 202nd image will delete the 2nd image, and so on.

11.4.2 Figure

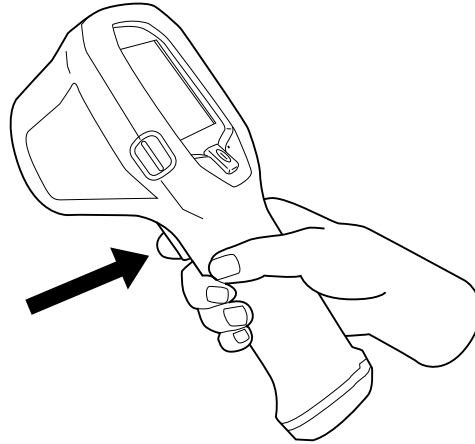

11.4.3 Procedure

Note The function of the trigger is configured by a setting in FLIR Tools, see section 11.10.2 *The User interface tab*, page 27.

Follow this procedure:

1. Aim the camera toward an object of interest.
2. To save an image, pull the trigger.

11.5 Recording a video clip (FLIR K53)

11.5.1 General

You can record video clips and save them to the camera's archive.

11.5.2 Figure

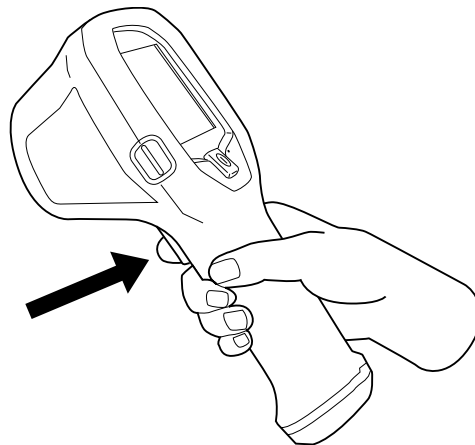

11.5.3 Procedure

Note The function of the trigger is configured by a setting in FLIR Tools, see section 11.10.2 *The User interface tab*, page 27.

Follow this procedure:

1. Aim the camera toward an object of interest.
2. Depending on the *Trigger button* setting in FLIR Tools, do one of the following to start the recording:
 - With the *Rec. on/off* setting, pull the trigger.
 - With the *Record video* setting, pull and hold the trigger.
3. A blinking circle in the middle left part of the screen indicates that the camera is currently recording a video clip.
4. Depending on the *Trigger button* setting in FLIR Tools, do one of the following to stop the recording:
 - With the *Rec. on/off* setting, pull the trigger.
 - With the *Record video* setting, release the trigger.

11.6 Continuous video recording (FLIR K53)

11.6.1 General

You can configure the camera to start a continuous video recording when you turn on the camera. The recording cannot be stopped.

Note The continuous video recording functionality is configured by a setting in FLIR Tools, see section 11.10.2 *The User interface tab*, page 27.

11.7 Freezing the image

11.7.1 General

You can freeze the image.

11.7.2 Figure

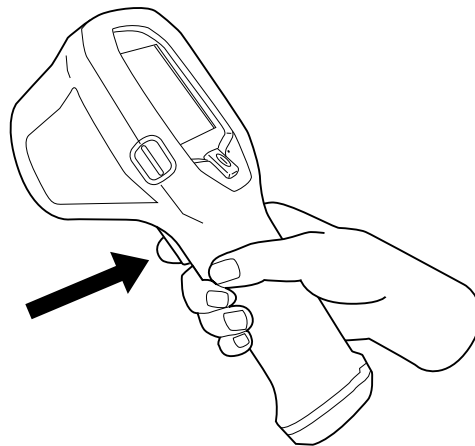

11.7.3 Procedure

Note The function of the trigger is configured by a setting in FLIR Tools, see section 11.10.2 *The User interface tab*, page 27.

Follow this procedure:

1. Aim the camera toward an object of interest.
2. Do the following:
 - To freeze the image, pull and hold the trigger.
 - To return to the live image, release the trigger.

11.8 Changing the temperature unit

The camera displays temperatures in °C or °F. You change the temperature unit by pushing a button behind the pin hole.

Note It is also possible to change the temperature unit using FLIR Tools. See section 11.10.2 *The User interface tab*, page 27.

Follow this procedure:

1. Turn on the camera.
2. Use a paper clip or a similar small item to push the button behind the pin hole.

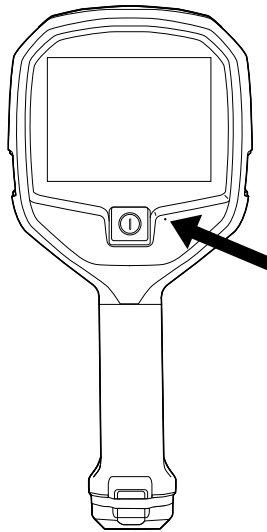

11.9 Connecting the camera to a computer

11.9.1 General

You can connect the camera to a computer, using the USB cable.

Once connected, you can do the following:

- Change the camera settings using the FLIR Tools software. See section 11.10 *Changing settings in FLIR Tools*, page 26.
- Applicable to FLIR K53: Move the images and video clips from the camera's archive to the computer.
- Applicable to FLIR K53: Import the images into the FLIR Tools software.

11.9.2 Procedure

Follow this procedure:

1. Fold up the rubber cover at the top of the camera.

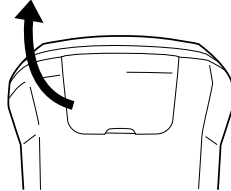

2. Hold the metal ring firmly.

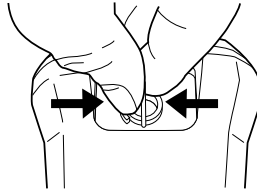

3. Rotate the ring about 90° counter-clockwise.

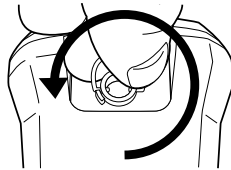

4. Pull out the plastic insert.

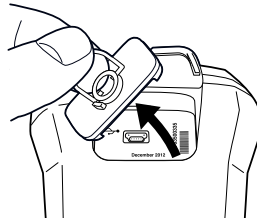
**CAUTION**

The plastic insert has an O-ring seal. Do not damage the O-ring seal.

5. Connect the USB cable to the USB Mini-B connector in the connector bay.

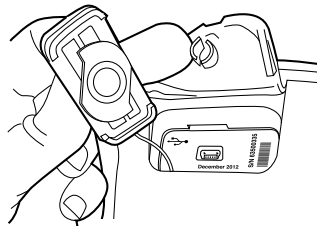

6. Applicable to FLIR K53:

- Move the images to the computer using a drag-and-drop operation in Microsoft Windows Explorer.

Note Moving an image using a drag-and-drop operation does not delete the image in the camera.

- Move the images to the computer using FLIR Tools.

11.10 Changing settings in FLIR Tools

11.10.1 The *General settings* tab

11.10.1.1 *Figure*

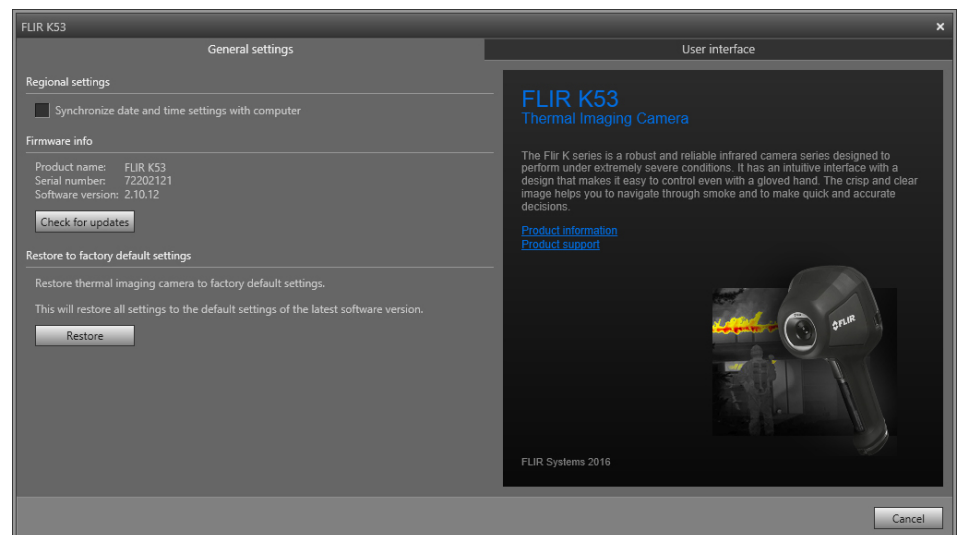

11.10.1.2 *Explanation*

Regional settings area: To synchronize the camera's date and time settings with the computer, select the checkbox.

Firmware info area: To check whether a newer version of the camera firmware exists, click *Check for updates* and follow the on-screen instructions.

Restore to factory default area: To restore all camera settings to the factory defaults, click *Restore*.

11.10.2 The *User interface* tab

11.10.2.1 Figure



11.10.2.2 Explanation

Camera mode area: The camera features one camera mode: Basic mode. For more information, see section 11.3 *Basic mode*, page 20.

Trigger button area: The camera has a trigger button. With the settings in the *Trigger button* area, you can select the function of the trigger button. You select what will happen when you click (short press) the trigger button and what will happen when you hold (long press) the trigger button.

- *No action, No action:* Select to disable any functionality of the trigger button. Nothing will happen when you press the trigger.
- *No action, Freeze image:* Select to make the camera freeze the image when you press and hold the trigger. The image will unfreeze when you release the trigger. Nothing will happen when you press the trigger momentarily.
- *No action, Record video* (not applicable to the FLIR K33): Select to make the camera start a recording when you press and hold the trigger. The recording will stop when you release the trigger. Nothing will happen when you press the trigger momentarily.
- *Save image, No action* (not applicable to the FLIR K33): Select to make the camera save an image when you press the trigger momentarily. Nothing will happen when you press and hold the trigger.
- *Save image, Freeze image* (not applicable to the FLIR K33): Select to make the camera save an image when you press the trigger momentarily and freeze the image when you press and hold the trigger. The image will unfreeze when you release the trigger.
- *Save image, Record video* (not applicable to the FLIR K33): Select to make the camera save an image when you press the trigger momentarily and start a recording when you press and hold the trigger. The recording will stop when you release the trigger.
- *Rec. on/off, No action* (not applicable to the FLIR K33): Select to make the camera start a recording when you press the trigger and stop the recording when you press the trigger again. Nothing will happen when you press and hold the trigger.
- *Continuous rec. (trigger disabled)* (not applicable to the FLIR K33): Select to make the camera start a continuous video recording when you turn on the camera. The recording cannot be stopped. Nothing will happen when you press the trigger.

Gain mode area:

- *Auto gain mode:* Select to make the camera automatically switch between the high-sensitivity range and the low-sensitivity range, depending on the scene temperature. The temperature level at which the camera switches between the two modes is 150°C (302°F).
- *Low gain mode:* Select to make the camera operate in the low-sensitivity range only. This has the advantage that the camera does not perform a non-uniformity correction (NUC) when an object with a temperature higher than 150°C (302°F) enters the scene. However, the disadvantage is lower sensitivity and a higher level of signal noise.

Temperature unit area: To select a different temperature unit, click *Celsius* or *Fahrenheit*.

Thermal indication area:

- *Digital readout only:* Select to display the thermal information in the image as the temperature of the spotmeter only. In modes with automatic heat colorization, the colorization of the image will remain but the static heat color reference icon will not be displayed.
- *Reference bar:* In modes with automatic heat indication colorization, a vertical heat color reference bar is displayed in the thermal indication area. This static icon shows how heat colors are applied to the range of the camera mode. The colors yellow, orange, and red correspond to a temperature-dependent change in hue as the temperature increases.
- *Temp bar:* Select to display the thermal information in the image as a temperature bar, similar to a thermometer. This displays a dynamic vertical temperature bar on the right-hand side of the image. The top of the dynamic bar represents the temperature of the measured spot. In modes with automatic heat colorization, the colorization of the image will remain, with a static heat color reference bar displayed next to the temperature bar.

Add custom boot image area: To select an image of your choice to appear during start-up, click *Browse*, and navigate to the image file. This is useful for, for example, identifying your fire department's cameras. By incorporating your fire department's logo, and a unique identity number in the image, you can keep track of your cameras. This image can also be accessed from the camera menu.

In-truck charger (optional accessory)

12.1 Introduction



Thank you for choosing the FLIR Kx3 series in-truck charger from FLIR Systems.

The in-truck charger is intended to be mounted on a flat surface in the cab, in one of the equipment lockers, or in another suitable compartment on the fire engine. The in-truck charger has five ports for cable routing—one through the rear of the metal bracket and one port on each side of the in-truck charger.

The in-truck charger can also be powered using a standard FLIR Systems power supply, and has a battery charger located at the lower front of the unit.

12.2 Parts and functions

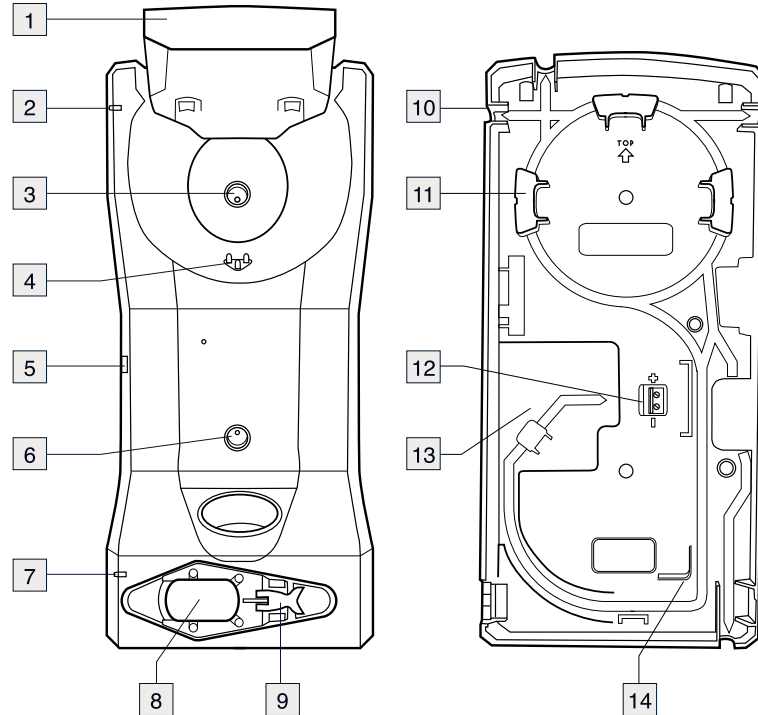

1. Top cover.
2. LED indicator for the camera charger.
3. Hole for attaching the charger housing to the metal bracket.
4. Connectors in the cradle.
5. Connector to power the charger using a standard FLIR Systems power supply.
6. Hole for attaching the charger housing to the metal bracket.
7. LED indicator for the battery charger.
8. Battery slot.
9. Eccentric latch to secure the battery during charging.
10. Cable port (1 of 4).

Note There is also one port through the rear of the metal bracket.

11. Routing support.
12. 12–24 VDC cable plinth.
13. Recess for the cable.
14. Routing support.

12.3 Choosing a suitable position

Before mounting the in-truck charger, take a few minutes to think about a suitable position.

The mounting position should be protected from rain and road splash, and it should be reasonably easy to install a permanent cable running from the fire engine's 12–24 VDC system to the in-truck charger.

Additional considerations may be important, e.g., getting access to panels and equipment behind the in-truck charger.

12.4 Recommended cable area and fuse

Cable area	1.5 mm ² (No. 15 AWG)
Fuse	5 A

12.5 Mounting instructions

Follow this procedure:

1. Permanently install a cable running from the fire engine's 12–24 VDC system to the selected mounting position of the in-truck charger. Do not connect this cable to the 12–24 VDC system at this time. The routing must include a fuse installed close to the battery. See above for the fuse recommendation.
2. Remove the two screws that hold the metal bracket.
3. Remove the metal bracket.
4. Use the metal bracket as a template to mark where the mounting holes should be drilled.
5. Drill the holes.
6. Mount the metal bracket using the rivets and/or screws that come with the in-truck charger.
7. Connect the cable to the cable plinth on the rear of the in-truck charger.

Note Take note of the polarity when you connect the cable to the cable plinth.
8. Route the cable so that it exits through the cable port of your choice.
9. Mount the in-truck charger to the metal bracket using the two screws that you removed in Step 2 above.
10. Permanently connect the cable to the fire engine's 12–24 VDC system.

12.6 Charging the camera

Follow this procedure:

1. Pull up the top cover of the in-truck charger.
2. Push the camera into position.
3. Push down the top cover.

The charging of the camera has now started, and is finished when the blue light glows continuously. Charging a fully depleted camera takes approximately 4 hours.

12.7 Charging a battery separately

FLIR Kx3 series batteries can be charged separately using the battery charger at the lower front of the unit.

Follow this procedure:

1. Pull the eccentric latch on the bottom of the camera.
2. Pull out the battery from the camera.
3. Push the battery into the slot at the lower front of the charger.
4. Secure the battery using the eccentric latch on the charger.

The charging of the battery has now started, and is finished when the blue light glows continuously. Charging a fully depleted battery takes approximately 4 hours.

12.8 Cleaning

**CAUTION**

Disconnect the in-truck charger from the fire engine's 12–24 VDC system before cleaning.

The in-truck charger can be cleaned using warm water or a weak detergent solution. Do not use solvents or similar liquids.

12.9 Customer support

Should you experience any problems, do not hesitate to contact our Customer Support at <http://support.flir.com>.

Table of contents

13.1	Online field-of-view calculator.....	33
13.2	Note about technical data.....	33
13.3	Note about authoritative versions.....	33
13.4	FLIR K33	34
13.5	FLIR K53	38
13.6	In-truck charger	42

13.1 Online field-of-view calculator

Please visit <http://support.flir.com> and click the photo of the camera series for field-of-view tables for all lens-camera combinations.

13.2 Note about technical data

FLIR Systems reserves the right to change specifications at any time without prior notice. Please check <http://support.flir.com> for latest changes.

13.3 Note about authoritative versions

The authoritative version of this publication is English. In the event of divergences due to translation errors, the English text has precedence.

Any late changes are first implemented in English.

13.4 FLIR K33

P/N: 72203-0411

Rev.: 41168

General description	
<p>The FLIR K33 is a robust and reliable infrared camera designed to perform under extremely severe conditions. The FLIR K33 has an intuitive interface with a design that makes it easy to control even with a gloved hand. The crisp and clear image helps you to navigate through smoke and to make quick and accurate decisions.</p>	
Benefits:	
<ul style="list-style-type: none"> • Robust and reliable: The FLIR K33 is designed to meet tough operating conditions. It can withstand a drop from 2 m (6.5 ft.) onto a concrete floor, is water resistant to IP67, and is fully operational up to +85°C (+185°F), or +260°C (+500°F) for 5 min. • Clear and crisp thermal images: The maintenance-free uncooled microbolometer sensor produces clear and detail-rich images of 240 × 180 pixels which have been further improved with FSX, a digital image processing enhancement technique. Thermal images are presented on a large, bright 4" display, helping you to navigate and to make quick and accurate decisions. • Easy-to-use—also in a gloved firefighter's hand: An intuitive and simple user interface allows you to focus on the job. The FLIR K33 can be controlled by just one large button on top of the unit. Ideal for a gloved firefighter's hand. 	
Imaging and optical data	
IR resolution	240 × 180 pixels
Thermal sensitivity/NETD	< 40 mK @ +30°C (+86°F)
Field of view (FOV)	51° × 38°
Depth of field	0.84 m to infinity (33 in. to infinity)
Focal length	9 mm (0.35 in.)
Spatial resolution (IFOV)	3.6 mrad
F-number	1.25
Image frequency	60 Hz
Focus	Fixed
Detector data	
Detector type	Focal plane array (FPA), uncooled microbolometer
Spectral range	7.5–13 μm
Pitch	25 μm
Image presentation	
Display	4 in. LCD, 320 × 240 pixels, backlit
Auto range	Yes, selectable on/off using FLIR Tools
Contrast optimization	Digital image enhancement using FSX
Image presentation modes	
Image modes	TI Basic fire-fighting mode

Measurement	
Object temperature range	<ul style="list-style-type: none"> • -20°C to +150°C (-4°F to +302°F) • 0°C to +650°C (+32°F to +1202°F)
Accuracy	±4°C (±7.2°F) or ±4% of reading, for ambient temperature 10°C to 35°C (+50°F to 95°F)
Measurement analysis	
Spotmeter	1
Isotherm	Yes
Set-up	
Set-up commands	Local adaptation of units, date and time formats
Languages	English
Video streaming	
Non-radiometric IR video streaming	Uncompressed colorized video using USB
USB	
USB	USB Mini-B
Compatibility	
Compatible with FLIR software	FLIR Tools
Data communication interfaces	
Interfaces	<ul style="list-style-type: none"> • Update from PC devices • Data transfer to and from PC
Power system	
Battery type	Li Ion
Battery voltage	3.6 V
Battery capacity	4.4 Ah, at +20°C to +25°C (+68°F to +77°F)
Battery operating time	Approx. 4 hours at +25°C (+77°F) ambient temperature and typical use
Charging system	<ul style="list-style-type: none"> • Battery is charged inside the camera • 2-bay charger • Optional In-truck charger
Charging time	2 h to 85% capacity, charging status indicated by LEDs
Charging temperature	0°C to +45°C (+32°F to +113°F)
Power management	Automatic shutdown and sleep mode
Start-up time from sleep mode	< 4 s.
Start-up time	< 17 s. (IR image, no GUI)
Environmental data	
Operating temperature range	<ul style="list-style-type: none"> • -20°C to +85°C (-4°F to +185°F) • +150°C (+302°F): 15 min. • +260°C (+500°F): 5 min.
Storage temperature range	-40°C to +85°C (-40°F to +185°F)

Environmental data	
Humidity (operating and storage)	IEC 60068-2-30/24 h 95% relative humidity +25°C to +40°C (+77°F to +104°F) / 2 cycles
Relative humidity	95% relative humidity +25°C to +40°C (+77°F to +104°F) non-condensing
Directives	Designed to meet NFPA 1801:2013 specification: <ul style="list-style-type: none"> • Vibration • Impact acceleration resistance • Corrosion • Viewing surface abrasion • Heat resistance • Heat and flame • Product label durability
EMC	<ul style="list-style-type: none"> • EN 61000-6-2:2005 (Immunity) • EN 61000-6-3: 2011 (Emission) • FCC 47 CFR Part 15 B (Emission)
Magnetic fields	EN 61 000-4-8, Test level 5 for continuous field (severe industrial environment)
Encapsulation	IP 67 (IEC 60529)
Shock	25 g (IEC 60068-2-27)
Vibration	2 g (IEC 60068-2-6)
Drop	2 m (6.6 ft.) on concrete floor (IEC 60068-2-31)
Safety (power supply)	CE/EN/UL/CSA/PSE 60950-1
Physical data	
Camera weight, incl. battery	1.1 ±0.05 kg (2.4 ±0.1 lb.)
Battery weight	0.152 kg (0.3 lb.)
Camera size (L × W × H)	120 × 125 × 280 mm (4.7 × 4.9 × 11 in.)
Tripod mounting	UNC ¼"-20 (adapter needed)
Material	<ul style="list-style-type: none"> • PPSU • Silicon rubber • Aluminium, cast • Flame-resistant magnesium alloy
Shipping information	
List of contents	<ul style="list-style-type: none"> • Infrared camera • Battery (2 ea.) • Battery charger • Hard transport case • Lanyard strap • Neck strap • Power supply • Printed documentation • Retractable lanyard • USB cable
Packaging, weight	5.7 kg (12.6 lb.)
Packaging, size	500 × 190 × 370 mm (19.7 × 7.5 × 14.6 in.)
EAN-13	7332558011515
UPC-12	845188012465
Country of origin	Estonia

Supplies & accessories:



- 1910423; USB cable Std A <-> Mini-B
- T198509; Cigarette lighter adapter kit, 12 VDC, 1.2 m/3.9 ft.
- T198125; Battery charger, incl. power supply with multi plugs (Exx, Kxx)
- T198310ACC; Li-Ion Battery pack 3.6 V 16 Wh
- T127724ACC; Neck strap
- T127722ACC; Retractable lanyard
- T198416ACC; Lanyard strap
- T198457ACC; Tripod Adapter, Kxx
- T198441ACC; Transport case Kxx
- T198322ACC; In-truck charger
- T199368ACC; Battery Li-ion 3.6 V, 4.4 Ah, 16 Wh
- T129915ACC; Carabiner strap

13.5 FLIR K53

P/N: 72203-0511

Rev.: 41168

General description	
<p>The FLIR K53 is a robust and reliable infrared camera designed to perform under extremely severe conditions. The FLIR K53 has an intuitive interface with a design that makes it easy to control even with a gloved hand. The crisp and clear image helps you to navigate through smoke and to make quick and accurate decisions.</p>	
<p>Benefits:</p> <ul style="list-style-type: none"> • Robust and reliable: The FLIR K53 is designed to meet tough operating conditions. It can withstand a drop from 2 m (6.5 ft.) onto a concrete floor, is water resistant to IP67, and is fully operational up to +85°C (+185°F), or +260°C (+500°F) for 5 min. • Clear and crisp thermal images: The maintenance-free uncooled microbolometer sensor produces clear and detail-rich images of 320 × 240 pixels which have been further improved with FSX, a digital image processing enhancement technique. Thermal images are presented on a large, bright 4" display, helping you to navigate and to make quick and accurate decisions. • Easy-to-use—also in a gloved firefighter's hand: An intuitive and simple user interface allows you to focus on the job. The FLIR K53 can be controlled by just one large button on top of the unit. Ideal for a gloved firefighter's hand. • Recording 	
Imaging and optical data	
IR resolution	320 × 240 pixels
Thermal sensitivity/NETD	< 30 mK @ +30°C (+86°F)
Field of view (FOV)	51° × 38°
Depth of field	0.84 m to infinity (33 in. to infinity)
Focal length	9 mm (0.35 in.)
Spatial resolution (IFOV)	2.8 mrad
F-number	1.25
Image frequency	60 Hz
Focus	Fixed
Detector data	
Detector type	Focal plane array (FPA), uncooled microbolometer
Spectral range	7.5–13 μm
Pitch	25 μm
Image presentation	
Display	4 in. LCD, 320 × 240 pixels, backlit
Auto range	Yes, selectable on/off using FLIR Tools
Contrast optimization	Digital image enhancement using FSX
Image presentation modes	
Image modes	TI Basic fire-fighting mode

Measurement	
Object temperature range	<ul style="list-style-type: none"> -20°C to +150°C (-4°F to +302°F) 0°C to +650°C (+32°F to +1202°F)
Accuracy	±4°C (±7.2°F) or ±4% of reading, for ambient temperature 10°C to 35°C (+50°F to 95°F)
Measurement analysis	
Spotmeter	1
Isotherm	Yes
Set-up	
Set-up commands	Local adaptation of units, date and time formats
Languages	English
Storage of images	
Image storage	Standard JPEG
Storage media	Internal flash memory
Image storage capacity	200 files in total <div style="border: 1px solid black; padding: 5px;">  NOTE The total number of files is co-dependent on the number of saved video clips. </div>
Image storage mode	IR only
File formats	Standard JPEG
Image annotations	
Report generation	Separate software (FLIR Tools)
Video recording in camera	
Non-radiometric IR video recording	MPEG-4 to internal flash memory
Storage capacity	200 files in total, with a maximum duration of 5 minutes each. <div style="border: 1px solid black; padding: 5px;">  NOTE The total number of files is co-dependent on the number of saved images. </div>
Video streaming	
Non-radiometric IR video streaming	Uncompressed colorized video using USB
USB	
USB	USB Mini-B
Compatibility	
Compatible with FLIR software	FLIR Tools
Data communication interfaces	
Interfaces	<ul style="list-style-type: none"> Update from PC devices Data transfer to and from PC

Power system	
Battery type	Li Ion
Battery voltage	3.6 V
Battery capacity	4.4 Ah, at +20°C to +25°C (+68°F to +77°F)
Battery operating time	Approx. 4 hours at +25°C (+77°F) ambient temperature and typical use
Charging system	<ul style="list-style-type: none"> • Battery is charged inside the camera • 2-bay charger • Optional In-truck charger
Charging time	2 h to 85% capacity, charging status indicated by LEDs
Charging temperature	0°C to +45°C (+32°F to +113°F)
Power management	Automatic shutdown and sleep mode
Start-up time from sleep mode	< 4 s.
Start-up time	< 17 s. (IR image, no GUI)
Environmental data	
Operating temperature range	<ul style="list-style-type: none"> • -20°C to +85°C (-4°F to +185°F) • +150°C (+302°F): 15 min. • +260°C (+500°F): 5 min.
Storage temperature range	-40°C to +85°C (-40°F to +185°F)
Humidity (operating and storage)	IEC 60068-2-30/24 h 95% relative humidity +25°C to +40°C (+77°F to +104°F) / 2 cycles
Relative humidity	95% relative humidity +25°C to +40°C (+77°F to +104°F) non-condensing
Directives	Designed to meet NFPA 1801:2013 specification: <ul style="list-style-type: none"> • Vibration • Impact acceleration resistance • Corrosion • Viewing surface abrasion • Heat resistance • Heat and flame • Product label durability
EMC	<ul style="list-style-type: none"> • EN 61000-6-2:2005 (Immunity) • EN 61000-6-3: 2011 (Emission) • FCC 47 CFR Part 15 B (Emission)
Magnetic fields	EN 61 000-4-8, Test level 5 for continuous field (severe industrial environment)
Encapsulation	IP 67 (IEC 60529)
Shock	25 g (IEC 60068-2-27)
Vibration	2 g (IEC 60068-2-6)
Drop	2 m (6.6 ft.) on concrete floor (IEC 60068-2-31)
Safety (power supply)	CE/EN/UL/CSA/PSE 60950-1
Physical data	
Camera weight, incl. battery	1.1 ±0.05 kg (2.4 ±0.1 lb.)
Battery weight	0.152 kg (0.3 lb.)
Camera size (L x W x H)	120 x 125 x 280 mm (4.7 x 4.9 x 11 in.)

Physical data	
Tripod mounting	UNC ¼"-20 (adapter needed)
Material	<ul style="list-style-type: none"> • PPSU • Silicon rubber • Aluminium, cast • Flame-resistant magnesium alloy
Shipping information	
List of contents	<ul style="list-style-type: none"> • Infrared camera • Battery (2 ea.) • Battery charger • Hard transport case • Lanyard strap • Neck strap • Power supply • Printed documentation • Retractable lanyard • USB cable
Packaging, weight	5.7 kg (12.6 lb.)
Packaging, size	500 × 190 × 370 mm (19.7 × 7.5 × 14.6 in.)
EAN-13	7332558011522
UPC-12	845188012472
Country of origin	Estonia

Supplies & accessories:

- 1910423; USB cable Std A <-> Mini-B
- T198509; Cigarette lighter adapter kit, 12 VDC, 1.2 m/3.9 ft.
- T198125; Battery charger, incl. power supply with multi plugs (Exx, Kxx)
- T198310ACC; Li-Ion Battery pack 3.6 V 16 Wh
- T127724ACC; Neck strap
- T127722ACC; Retractable lanyard
- T198416ACC; Lanyard strap
- T198457ACC; Tripod Adapter, Kxx
- T198441ACC; Transport case Kxx
- T198322ACC; In-truck charger
- T199368ACC; Battery Li-ion 3.6 V, 4.4 Ah, 16 Wh
- T129915ACC; Carabiner strap

13.6 In-truck charger

P/N: T198322

Rev.: 28825

Power system	
Charging time	< 4 hours
Charging temperature	0°C to +45°C (+32°F to +113°F)
External power, connector type	Screw terminal or HRS_UK60-3PT
DC operation	12/ 24 V DCnominal (11.1 - 28.0 V DC)
Power	Max 36 Watts or 3000 mA at 12 VDC (5 amps fuse)
Environmental data	
Operating temperature range	-40°C to +85°C (-40°F to +185°F)
Storage temperature range	-40°C to +85°C (-40°F to +185°F)
Relative humidity	Operational for non-condensing humidity between 5% and 95%.
EMC	<ul style="list-style-type: none"> • EN61000-6-3 Emission • EN61000-6-2 Immunity • FCC47CFR part 15 class B • NFPA requirements • ISO 7637-2 Road vehicles - Electrical disturbances from conduction and coupling Part 2: Electrical transient conduction along supply lines only
Encapsulation	IP 20
Bump	Operational after exposed to: 5 pulses/ in each axis/ direction (30 total) of 30g 11ms half sine profile
Vibration	Operational after exposed to: 4, 3g rms random profile. 8 hours in each axis.
Physical data	
Weight	1.050 kg
Size (L x W x H)	380 mm x 180 mm x 153 mm (15 in. x 7.1 in. x 6 in.)
Material	PC / ABS
Color	Grey / black
Shipping information	
List of contents	<ul style="list-style-type: none"> • Charger • Documentation • Card board box
Packaging, weight	3.2 kg (7.0 lb.)
Packaging, size	435 x 245 x 167 mm (17.1 x 9.6 x 6.6 in.)
EAN-13	7332558005446 4743254001282 (Estonia plant)

Shipping information	
UPC-12	845188005368
Country of origin	Estonia

Compatible with the following products

- 72201-0106; FLIR K45
- 72201-0206; FLIR K55
- 72202-0303; FLIR K65

[See next page]

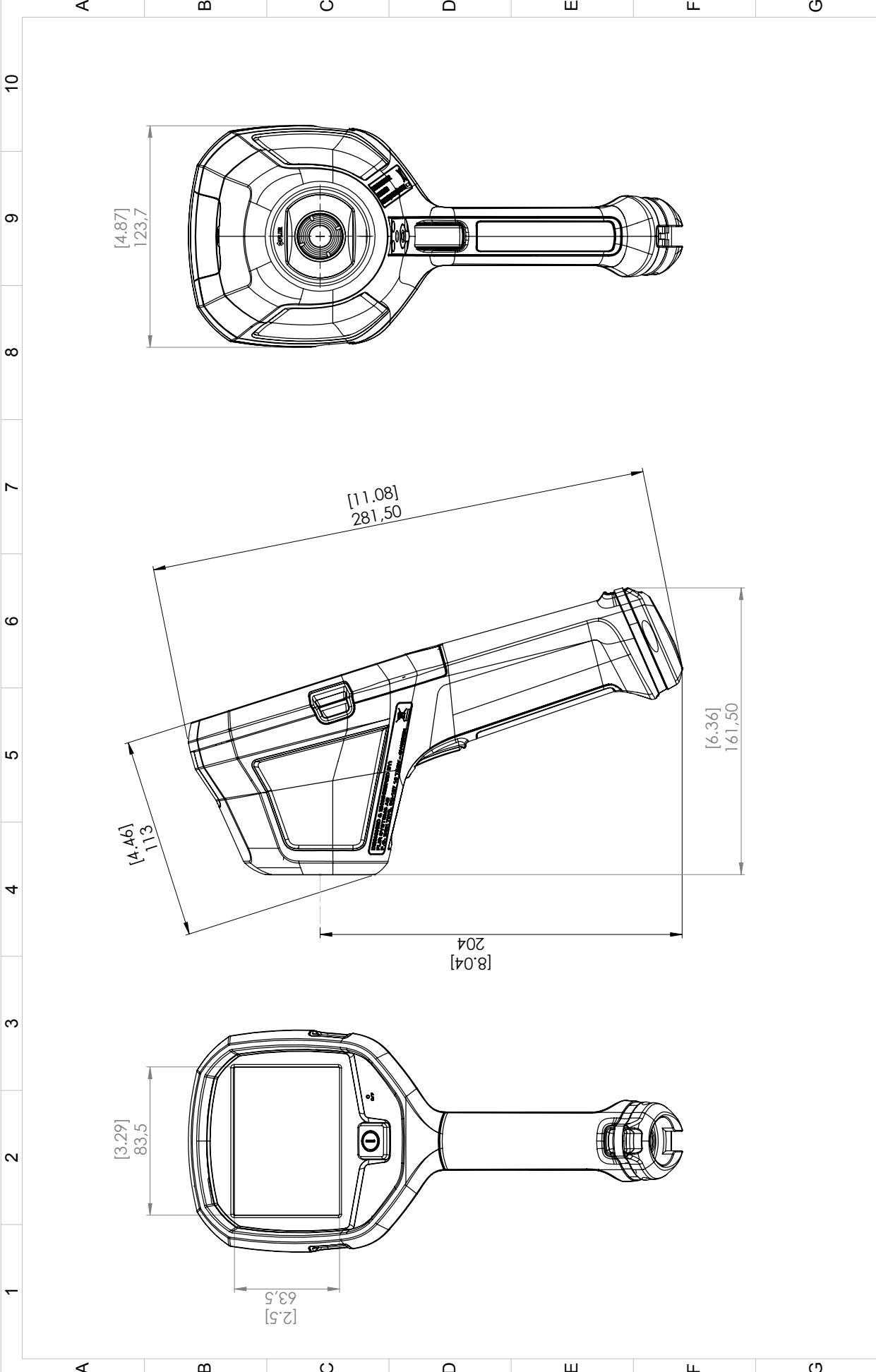

FLIR		Material	
Sheet/Scale	1:2	Material	Ytbehandling/Surface treatment
Blad/Sheet Size	A3	Ytämhet/Roughness Ra	µm
Rev		Benämning/Denomination	
Basic dimension drawing			
Kontroll/Drawn		Datum/Date	
A. LUND		2016-03-23	
Ändrad av/Modified by		Ändrat/Modified	
A. LUND		2016-03-29	
Det ej annat anges/Unless otherwise stated Genom ISO 2768-mK Utgång ur/Except from ISO 2768-m 0,5-6 Hållradier (30)-120 Filter radii ±0,3 Kanter brutna (400)-1000 ±0,8 Edges broken			

Denna handling får ej delges annan, kopieras i sin helhet eller delar utan vårt medgivande. Översättningar och revideringar är tillåtna utan vidare tillstånd från FLIR SYSTEMS AB. This document must not be communicated or copied completely or in part, without our permission. Any infringement will lead to legal proceedings. FLIR SYSTEMS AB

Den här handlingen är ett tekniskt dokument och kan innehålla fel. För ytterligare information, vänligen kontakta oss på support@flir.com. This document is a technical drawing and may contain errors. For further information, please contact us at support@flir.com.

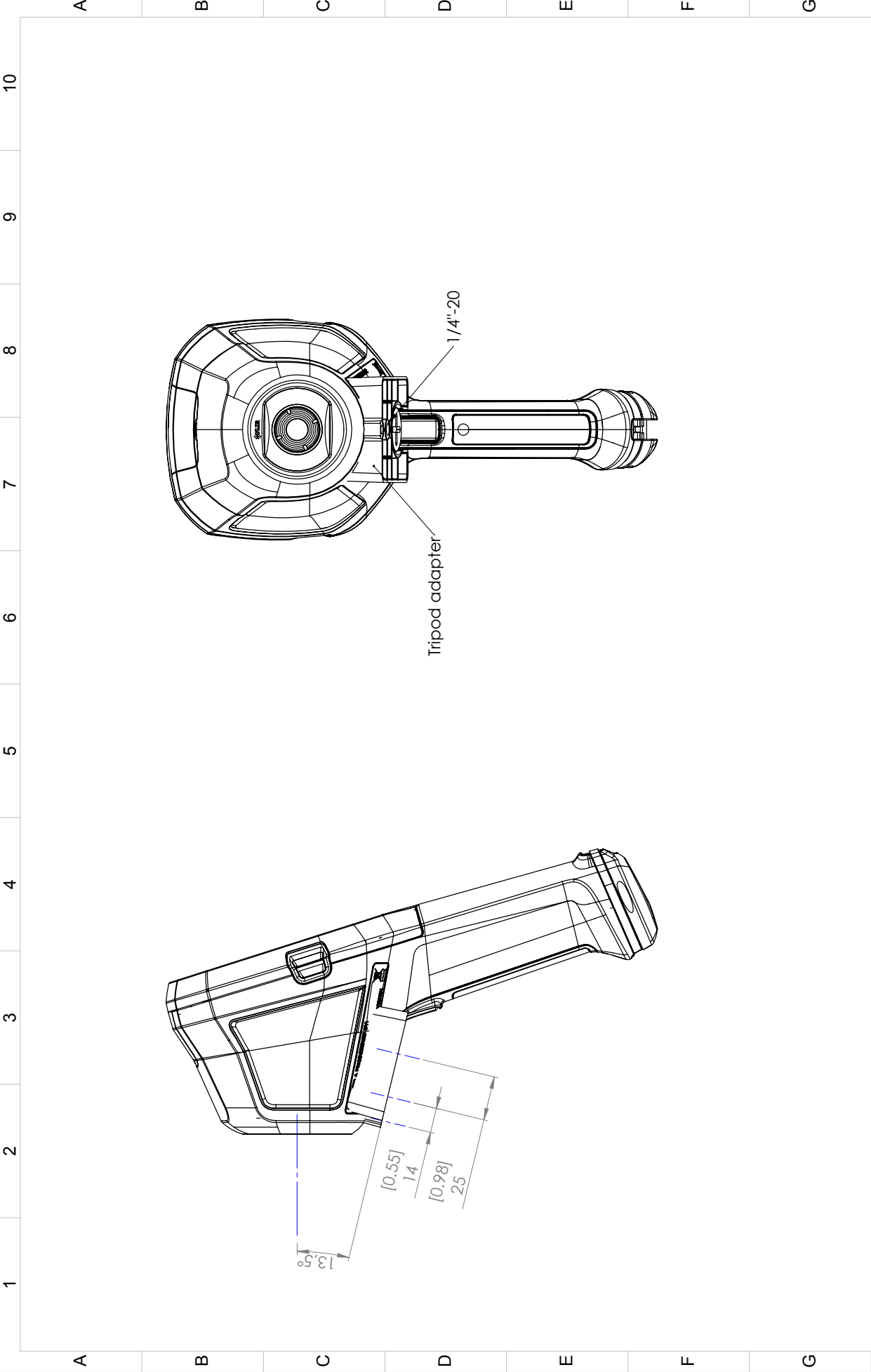

Konstr/Drawn A. LUND	Datum/Date 2016-03-23	Kontroll/Check -	Material -
Ändrad av/Modified by A. LUND	Ändrad/Modified 2016-03-29	Ytjämnhet/Roughness Ra	Ytbehandling/Surface treatment
Dir ej ansvar ängas/Unless otherwise stated Genför ISO 2768-mK UTdrag ur/Excerpt from ISO 2768-m	Benämning/Denomination	Stela/Scale 1:2	Blad/Sheet 2(2)
0.5° 0.30 (30)-120 (20)-400 (40)-1600	40.1 Fläktblad Fläkt rad Kontor brutna ±0.5 ±0.5	Artno.	Blad/Sheet Size A3
Basic dimension drawing			Ritn nr/Drawing No Kx3
			Rev

Denna handling får ej delges annan, kopieras
 eller på annat sätt spridas utan vårt medgivande.
 FLIR SYSTEMS AB
 Any infringement will lead to legal proceedings.
 This document must not be communicated or
 copied completely or in part, without our permission.
 FLIR SYSTEMS AB

Denna handling får ej delges annan, kopieras
 eller på annat sätt spridas utan vårt medgivande.
 FLIR SYSTEMS AB
 Any infringement will lead to legal proceedings.
 This document must not be communicated or
 copied completely or in part, without our permission.
 FLIR SYSTEMS AB

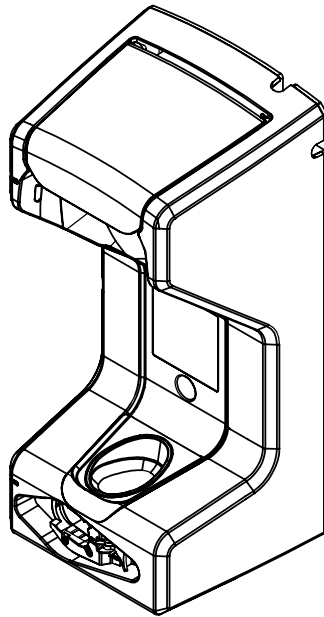
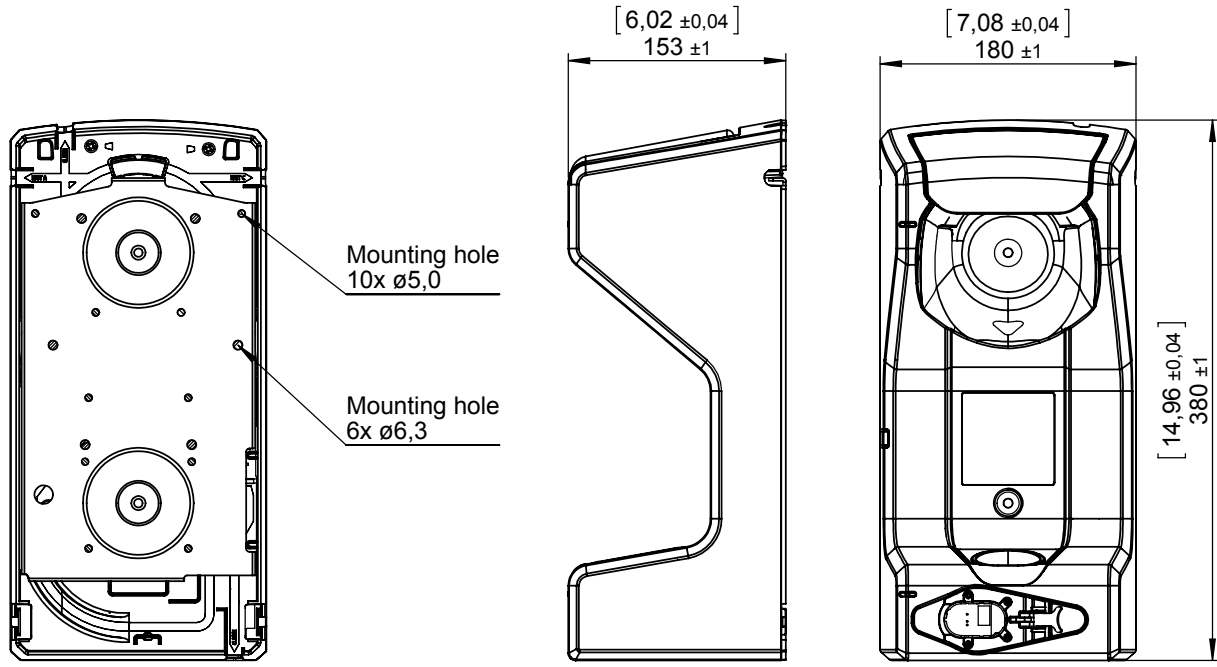

Konstr/Drawn P. MARCUS	Datum/Date 2013-04-08	Kontr/Check MABR	Material			
Ändrad av/Modified by P. MARCUS	Ändrad/Modified 2013-04-08	Ytjämnhet/Roughness Ra μm	Ytbehandling/Surface treatment			
Där ej annat anges/Unless otherwise stated Gen tol ISO 2768-mK Utdrag ur/Excerpt from ISO 2768-m	Benämning/Denomination Basic dimensions In-truck charger			Skala/Scale 1:5		Blad/Sheet 1(1)
0.5-6 $\pm 0,1$ Hålkålsradier (6)-30 $\pm 0,2$ Fillet radii (30)-120 $\pm 0,3$ (120)-400 $\pm 0,5$ Kanter brutna (400)-1000 $\pm 0,8$ Edges broken				Art.No.		Size A4
				Ritn nr/Drawing No T127865	Rev A	

[See next page]



The World's Sixth Sense™

January 11, 2017 Täby, Sweden

AQ320212

CE Declaration of Conformity – EU Declaration of Conformity

Product: FLIR KXX series

Name and address of the manufacturer:

FLIR Systems AB

PO Box 7376

SE-187 15 Täby, Sweden

This declaration of conformity is issued under the sole responsibility of the manufacturer.

The object of the declaration: FLIR KXX series

The object of the declaration described above is in conformity with the relevant Union harmonisation legislation:

Directives:

Directive	2014/30/EU	Electromagnetic Compability
Directive	2014/35/EU	Low Voltage Directive (Power Supply)
Directive	2012/19/EU	Waste electrical and electric equipment

Standards:

Emission	EN 61000-6-3:2007+A1:2011	Electromagnetic Compability Generic standards – Emission
Immunity	EN 61000-6-2:2005	Electromagnetic Compability Generic standards – Immunity
Safety (Power Supply)	IEC 60950-1:2005+A1	Information technology equipment - Safety

FLIR Systems AB

Quality Assurance

Lea Dabiri

Quality Manager

Cleaning, decontamination and disinfection

16.1 Cleaning

16.1.1 Camera housing, cables, and other items

16.1.1.1 Liquids

Use one of these liquids:

- Warm water
- A weak detergent solution

16.1.1.2 Equipment

A soft cloth

16.1.1.3 Procedure

Follow this procedure:

1. Soak the cloth in the liquid.
2. Twist the cloth to remove excess liquid.
3. Clean the part with the cloth.

**CAUTION**

Do not apply solvents or similar liquids to the camera, the cables, or other items. This can cause damage.

16.1.2 Infrared lens

16.1.2.1 Liquids

Use one of these liquids:

- A commercial lens cleaning liquid with more than 30% isopropyl alcohol.
- 96% ethyl alcohol (C_2H_5OH).

16.1.2.2 Equipment

Cotton wool

**CAUTION**

If you use a lens cleaning cloth it must be dry. Do not use a lens cleaning cloth with the liquids that are given in section 16.1.2.1 above. These liquids can cause material on the lens cleaning cloth to become loose. This material can have an unwanted effect on the surface of the lens.

16.1.2.3 Procedure

Follow this procedure:

1. Soak the cotton wool in the liquid.
2. Twist the cotton wool to remove excess liquid.
3. Clean the lens one time only and discard the cotton wool.

**WARNING**

Make sure that you read all applicable MSDS (Material Safety Data Sheets) and warning labels on containers before you use a liquid: the liquids can be dangerous.

**CAUTION**

- Be careful when you clean the infrared lens. The lens has a delicate anti-reflective coating.
- Do not clean the infrared lens too vigorously. This can damage the anti-reflective coating.

16.2 Decontamination and disinfection

- The camera must be thoroughly cleaned, decontaminated and disinfected before shipping to our service department. No hazardous residues are allowed on cameras. Such residues include—but are not limited to—chemical fire-extinguishing compounds, radioactivity, biohazardous materials, and residues from chemical fires.
- FLIR Systems reserves the right to charge the full cost for the decontamination and disinfection of contaminated cameras that are shipped to our service department.

Maintenance, inspection, and service

The following maintenance and inspection procedures apply.

17.1 Maintenance

After each use:

1. Clean the camera according to section 16.1 *Cleaning*, page 50.
2. Charge the battery according to section 11.1.1 *Charging the battery*, page 19.

17.2 Inspection

After each use:

1. Verify the function and integrity of the latch that secures the battery.



CAUTION

Make sure that you do not use a torque value that is more than 80 Ncm on the Torx T20 screw. Damage to the camera can occur if you do not obey this.

2. Inspect the lens for scratches.
3. Inspect the screen for scratches.
4. Inspect the camera body for damage.
5. Verify the function of all buttons and triggers.
6. Inspect the attachment point for the lanyard strap/neck strap, and the attachment point for the retractable lanyard.

17.3 Service

For contact details to our service departments, use the following link:

<http://support.flir.com/service>

Storage conditions

The following storage conditions apply.

Storage temperature range	-40°C to +85°C (-40°F to +185°F)
Storage humidity	IEC 60068-2-30/24 h 95% relative humidity +25°C to +40°C (+77°F to +104°F) / 2 cycles

About FLIR Systems

FLIR Systems was established in 1978 to pioneer the development of high-performance infrared imaging systems, and is the world leader in the design, manufacture, and marketing of thermal imaging systems for a wide variety of commercial, industrial, and government applications. Today, FLIR Systems embraces five major companies with outstanding achievements in infrared technology since 1958—the Swedish AGEMA Infrared Systems (formerly AGA Infrared Systems), the three United States companies Indigo Systems, FSI, and Inframetrics, and the French company Cedicp.

Since 2007, FLIR Systems has acquired several companies with world-leading expertise in sensor technologies:

- Exttech Instruments (2007)
- Ifara Tecnologías (2008)
- Salvador Imaging (2009)
- OmniTech Partners (2009)
- Directed Perception (2009)
- Raymarine (2010)
- ICx Technologies (2010)
- TackTick Marine Digital Instruments (2011)
- Aerius Photonics (2011)
- Lorex Technology (2012)
- Traficon (2012)
- MARSS (2013)
- DigitalOptics micro-optics business (2013)
- DVTEL (2015)
- Point Grey Research (2016)
- Prox Dynamics (2016)

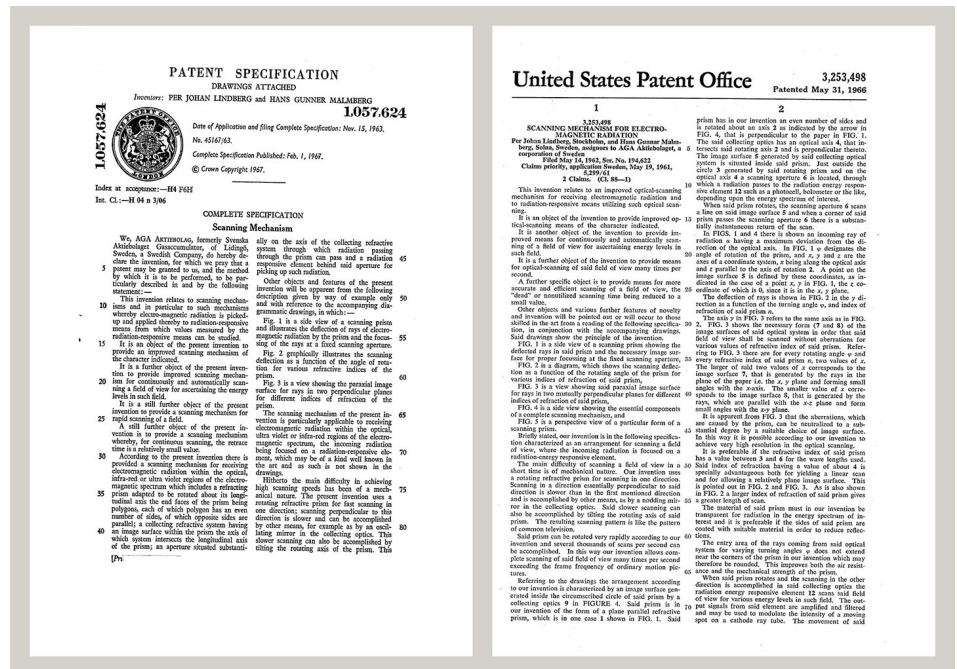

Figure 19.1 Patent documents from the early 1960s

FLIR Systems has three manufacturing plants in the United States (Portland, OR, Boston, MA, Santa Barbara, CA) and one in Sweden (Stockholm). Since 2007 there is also a

manufacturing plant in Tallinn, Estonia. Direct sales offices in Belgium, Brazil, China, France, Germany, Great Britain, Hong Kong, Italy, Japan, Korea, Sweden, and the USA— together with a worldwide network of agents and distributors—support our international customer base.

FLIR Systems is at the forefront of innovation in the infrared camera industry. We anticipate market demand by constantly improving our existing cameras and developing new ones. The company has set milestones in product design and development such as the introduction of the first battery-operated portable camera for industrial inspections, and the first uncooled infrared camera, to mention just two innovations.

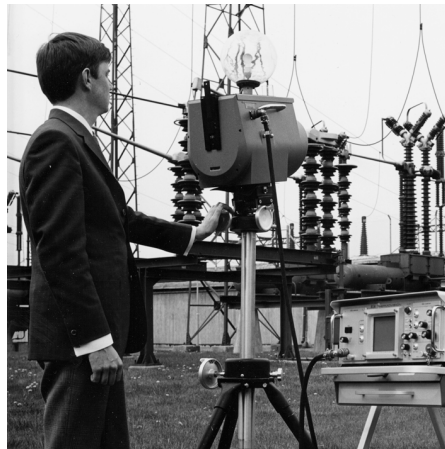

Figure 19.2 1969: Thermovision Model 661. The camera weighed approximately 25 kg (55 lb.), the oscilloscope 20 kg (44 lb.), and the tripod 15 kg (33 lb.). The operator also needed a 220 VAC generator set, and a 10 L (2.6 US gallon) jar with liquid nitrogen. To the left of the oscilloscope the Polaroid attachment (6 kg/13 lb.) can be seen.



Figure 19.3 2015: FLIR One, an accessory to iPhone and Android mobile phones. Weight: 90 g (3.2 oz.).

FLIR Systems manufactures all vital mechanical and electronic components of the camera systems itself. From detector design and manufacturing, to lenses and system electronics, to final testing and calibration, all production steps are carried out and supervised by our own engineers. The in-depth expertise of these infrared specialists ensures the accuracy and reliability of all vital components that are assembled into your infrared camera.

19.1 More than just an infrared camera

At FLIR Systems we recognize that our job is to go beyond just producing the best infrared camera systems. We are committed to enabling all users of our infrared camera systems to work more productively by providing them with the most powerful camera–software combination. Especially tailored software for predictive maintenance, R & D, and process monitoring is developed in-house. Most software is available in a wide variety of languages.

We support all our infrared cameras with a wide variety of accessories to adapt your equipment to the most demanding infrared applications.

19.2 Sharing our knowledge

Although our cameras are designed to be very user-friendly, there is a lot more to thermography than just knowing how to handle a camera. Therefore, FLIR Systems has founded the Infrared Training Center (ITC), a separate business unit, that provides certified training courses. Attending one of the ITC courses will give you a truly hands-on learning experience.

The staff of the ITC are also there to provide you with any application support you may need in putting infrared theory into practice.

19.3 Supporting our customers

FLIR Systems operates a worldwide service network to keep your camera running at all times. If you discover a problem with your camera, local service centers have all the equipment and expertise to solve it within the shortest possible time. Therefore, there is no need to send your camera to the other side of the world or to talk to someone who does not speak your language.

Before the year 1800, the existence of the infrared portion of the electromagnetic spectrum wasn't even suspected. The original significance of the infrared spectrum, or simply 'the infrared' as it is often called, as a form of heat radiation is perhaps less obvious today than it was at the time of its discovery by Herschel in 1800.

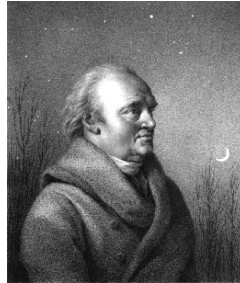

Figure 20.1 Sir William Herschel (1738–1822)

The discovery was made accidentally during the search for a new optical material. Sir William Herschel – Royal Astronomer to King George III of England, and already famous for his discovery of the planet Uranus – was searching for an optical filter material to reduce the brightness of the sun's image in telescopes during solar observations. While testing different samples of colored glass which gave similar reductions in brightness he was intrigued to find that some of the samples passed very little of the sun's heat, while others passed so much heat that he risked eye damage after only a few seconds' observation.

Herschel was soon convinced of the necessity of setting up a systematic experiment, with the objective of finding a single material that would give the desired reduction in brightness as well as the maximum reduction in heat. He began the experiment by actually repeating Newton's prism experiment, but looking for the heating effect rather than the visual distribution of intensity in the spectrum. He first blackened the bulb of a sensitive mercury-in-glass thermometer with ink, and with this as his radiation detector he proceeded to test the heating effect of the various colors of the spectrum formed on the top of a table by passing sunlight through a glass prism. Other thermometers, placed outside the sun's rays, served as controls.

As the blackened thermometer was moved slowly along the colors of the spectrum, the temperature readings showed a steady increase from the violet end to the red end. This was not entirely unexpected, since the Italian researcher, Landriani, in a similar experiment in 1777 had observed much the same effect. It was Herschel, however, who was the first to recognize that there must be a point where the heating effect reaches a maximum, and that measurements confined to the visible portion of the spectrum failed to locate this point.



Figure 20.2 Marsilio Landriani (1746–1815)

Moving the thermometer into the dark region beyond the red end of the spectrum, Herschel confirmed that the heating continued to increase. The maximum point, when he found it, lay well beyond the red end – in what is known today as the ‘infrared wavelengths’.

When Herschel revealed his discovery, he referred to this new portion of the electromagnetic spectrum as the ‘thermometrical spectrum’. The radiation itself he sometimes referred to as ‘dark heat’, or simply ‘the invisible rays’. Ironically, and contrary to popular opinion, it wasn't Herschel who originated the term ‘infrared’. The word only began to appear in print around 75 years later, and it is still unclear who should receive credit as the originator.

Herschel's use of glass in the prism of his original experiment led to some early controversies with his contemporaries about the actual existence of the infrared wavelengths. Different investigators, in attempting to confirm his work, used various types of glass indiscriminately, having different transparencies in the infrared. Through his later experiments, Herschel was aware of the limited transparency of glass to the newly-discovered thermal radiation, and he was forced to conclude that optics for the infrared would probably be doomed to the use of reflective elements exclusively (i.e. plane and curved mirrors). Fortunately, this proved to be true only until 1830, when the Italian investigator, Melloni, made his great discovery that naturally occurring rock salt (NaCl) – which was available in large enough natural crystals to be made into lenses and prisms – is remarkably transparent to the infrared. The result was that rock salt became the principal infrared optical material, and remained so for the next hundred years, until the art of synthetic crystal growing was mastered in the 1930's.



Figure 20.3 Macedonio Melloni (1798–1854)

Thermometers, as radiation detectors, remained unchallenged until 1829, the year Nobili invented the thermocouple. (Herschel's own thermometer could be read to $0.2\text{ }^{\circ}\text{C}$ ($0.036\text{ }^{\circ}\text{F}$), and later models were able to be read to $0.05\text{ }^{\circ}\text{C}$ ($0.09\text{ }^{\circ}\text{F}$)). Then a breakthrough occurred; Melloni connected a number of thermocouples in series to form the first thermopile. The new device was at least 40 times as sensitive as the best thermometer of the day for detecting heat radiation – capable of detecting the heat from a person standing three meters away.

The first so-called ‘heat-picture’ became possible in 1840, the result of work by Sir John Herschel, son of the discoverer of the infrared and a famous astronomer in his own right. Based upon the differential evaporation of a thin film of oil when exposed to a heat pattern focused upon it, the thermal image could be seen by reflected light where the interference effects of the oil film made the image visible to the eye. Sir John also managed to obtain a primitive record of the thermal image on paper, which he called a ‘thermograph’.



Figure 20.4 Samuel P. Langley (1834–1906)

The improvement of infrared-detector sensitivity progressed slowly. Another major breakthrough, made by Langley in 1880, was the invention of the bolometer. This consisted of a thin blackened strip of platinum connected in one arm of a Wheatstone bridge circuit upon which the infrared radiation was focused and to which a sensitive galvanometer responded. This instrument is said to have been able to detect the heat from a cow at a distance of 400 meters.

An English scientist, Sir James Dewar, first introduced the use of liquefied gases as cooling agents (such as liquid nitrogen with a temperature of $-196\text{ }^{\circ}\text{C}$ ($-320.8\text{ }^{\circ}\text{F}$)) in low temperature research. In 1892 he invented a unique vacuum insulating container in which it is possible to store liquefied gases for entire days. The common ‘thermos bottle’, used for storing hot and cold drinks, is based upon his invention.

Between the years 1900 and 1920, the inventors of the world ‘discovered’ the infrared. Many patents were issued for devices to detect personnel, artillery, aircraft, ships – and even icebergs. The first operating systems, in the modern sense, began to be developed during the 1914–18 war, when both sides had research programs devoted to the military exploitation of the infrared. These programs included experimental systems for enemy intrusion/detection, remote temperature sensing, secure communications, and ‘flying torpedo’ guidance. An infrared search system tested during this period was able to detect an approaching airplane at a distance of 1.5 km (0.94 miles), or a person more than 300 meters (984 ft.) away.

The most sensitive systems up to this time were all based upon variations of the bolometer idea, but the period between the two wars saw the development of two revolutionary new infrared detectors: the image converter and the photon detector. At first, the image converter received the greatest attention by the military, because it enabled an observer for the first time in history to literally ‘see in the dark’. However, the sensitivity of the image converter was limited to the near infrared wavelengths, and the most interesting military targets (i.e. enemy soldiers) had to be illuminated by infrared search beams. Since this involved the risk of giving away the observer’s position to a similarly-equipped enemy observer, it is understandable that military interest in the image converter eventually faded.

The tactical military disadvantages of so-called ‘active’ (i.e. search beam-equipped) thermal imaging systems provided impetus following the 1939–45 war for extensive secret military infrared-research programs into the possibilities of developing ‘passive’ (no search beam) systems around the extremely sensitive photon detector. During this period, military secrecy regulations completely prevented disclosure of the status of infrared-imaging technology. This secrecy only began to be lifted in the middle of the 1950’s, and from that time adequate thermal-imaging devices finally began to be available to civilian science and industry.

A note on the technical production of this publication

This publication was produced using XML — the eXtensible Markup Language. For more information about XML, please visit <http://www.w3.org/XML/>

A note on the typeface used in this publication

This publication was typeset using Linotype Helvetica™ World. Helvetica™ was designed by Max Miedinger (1910–1980)

LOEF (List Of Effective Files)

T501215.xml; en-US; AE; 41948; 2017-04-06
T505471.xml; en-US; 9229; 2013-10-03
T505846.xml; en-US; 39792; 2017-01-30
T505013.xml; en-US; 39689; 2017-01-25
T505691.xml; en-US; 39865; 2017-01-31
T505516.xml; en-US; 39792; 2017-01-30
T505981.xml; en-US; 39793; 2017-01-30
T505980.xml; en-US; 39792; 2017-01-30
T505990.xml; en-US; 39792; 2017-01-30
T505007.xml; en-US; 39512; 2017-01-18
T505005.xml; en-US; 39512; 2017-01-18



Website

<http://www.flir.com>

Customer support

<http://support.flir.com>

Copyright

© 2017, FLIR Systems, Inc. All rights reserved worldwide.

Disclaimer

Specifications subject to change without further notice. Models and accessories subject to regional market considerations. License procedures may apply. Products described herein may be subject to US Export Regulations. Please refer to exportquestions@flir.com with any questions.



Call Us 1.877.571.7901

Publ. No.: T810170
Release: AE
Commit: 41948
Head: 41948
Language: en-US
Modified: 2017-04-06
Formatted: 2017-04-06