

Model 428 Current Amplifier

Instruction Manual

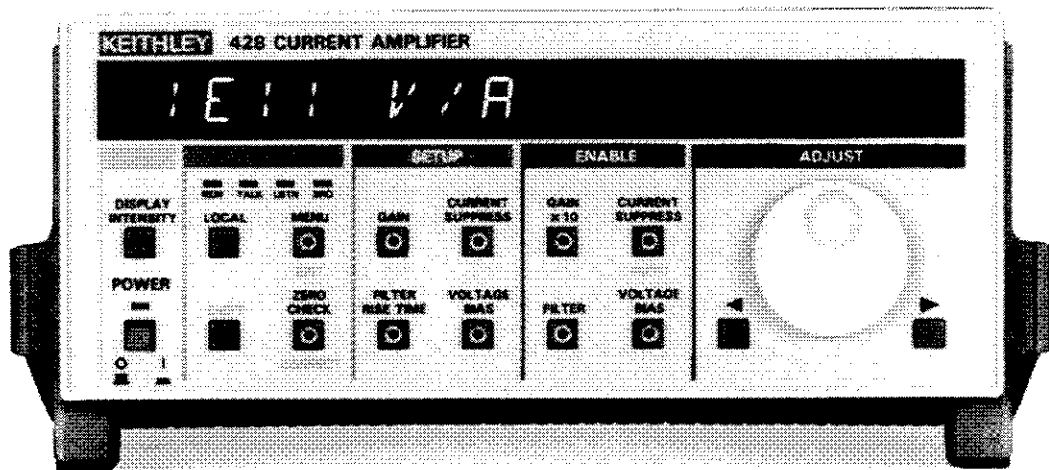

Contains Operating and Servicing Information

KEITHLEY

WARRANTY

Keithley Instruments, Inc. warrants this product to be free from defects in material and workmanship for a period of 1 year from date of shipment.

Keithley Instruments, Inc. warrants the following items for 90 days from the date of shipment: probes, cables, rechargeable batteries, diskettes, and documentation.

During the warranty period, we will, at our option, either repair or replace any product that proves to be defective.

To exercise this warranty, write or call your local Keithley representative, or contact Keithley headquarters in Cleveland, Ohio. You will be given prompt assistance and return instructions. Send the product, transportation prepaid, to the indicated service facility. Repairs will be made and the product returned, transportation prepaid. Repaired or replaced products are warranted for the balance of the original warranty period, or at least 90 days.

LIMITATION OF WARRANTY

This warranty does not apply to defects resulting from product modification without Keithley's express written consent, or misuse of any product or part. This warranty also does not apply to fuses, software, non-rechargeable batteries, damage from battery leakage, or problems arising from normal wear or failure to follow instructions.

THIS WARRANTY IS IN LIEU OF ALL OTHER WARRANTIES, EXPRESSED OR IMPLIED, INCLUDING ANY IMPLIED WARRANTY OF MERCHANTABILITY OR FITNESS FOR A PARTICULAR USE. THE REMEDIES PROVIDED HEREIN ARE BUYER'S SOLE AND EXCLUSIVE REMEDIES.

NEITHER KEITHLEY INSTRUMENTS, INC. NOR ANY OF ITS EMPLOYEES SHALL BE LIABLE FOR ANY DIRECT, INDIRECT, SPECIAL, INCIDENTAL OR CONSEQUENTIAL DAMAGES ARISING OUT OF THE USE OF ITS INSTRUMENTS AND SOFTWARE EVEN IF KEITHLEY INSTRUMENTS, INC., HAS BEEN ADVISED IN ADVANCE OF THE POSSIBILITY OF SUCH DAMAGES. SUCH EXCLUDED DAMAGES SHALL INCLUDE, BUT ARE NOT LIMITED TO: COSTS OF REMOVAL AND INSTALLATION, LOSSES SUSTAINED AS THE RESULT OF INJURY TO ANY PERSON, OR DAMAGE TO PROPERTY.

KEITHLEY

Keithley Instruments, Inc. • 28775 Aurora Road • Cleveland, OH 44139 • 440-248-0400 • Fax: 440-248-6168 • <http://www.keithley.com>

CHINA: Keithley Instruments China • Yuan Chen Xin Building, Room 705 • 12 Yumin Road, Dewai, Madian • Beijing 100029 • 8610-62022886 • Fax: 8610-62022892
FRANCE: Keithley Instruments SARL • BP 60 • 3 Allée des Garays • 91122 Palaiseau Cédex • 33-1-60-11-51-55 • Fax: 33-1-60-11-77-26
GERMANY: Keithley Instruments GmbH • Landsberger Strasse 65 • D-82110 Germering, Munich • 49-89-8493070 • Fax: 49-89-84930759
GREAT BRITAIN: Keithley Instruments, Ltd. • The Minster • 58 Portman Road • Reading, Berkshire, England RG3 1EA • 44-1189-596469 • Fax: 44-1189-575666
ITALY: Keithley Instruments SRL • Viale S. Gimignano 38 • 20146 Milano • 39-2-48303008 • Fax: 39-2-48302274
NETHERLANDS: Keithley Instruments BV • Avelingen West 49 • 4202 MS Gorinchem • 31-(0)183-635333 • Fax: 31-(0)183-630821
SWITZERLAND: Keithley Instruments SA • Kriesbachstrasse 4 • 8600 Dübendorf • 41-1-8219444 • Fax: 41-1-8203081
TAIWAN: Keithley Instruments Taiwan • IFL.. 85 Po Ai Street • Hsinchu, Taiwan • 886-3-572-9077 • Fax: 886-3-572-9031

Model 428 Current Amplifier Instruction Manual

©1990, Keithley Instruments, Inc.
All rights reserved.
Cleveland, Ohio, U.S.A.
Fourth Printing, February 1999
Document Number: 428-901-01 Rev. D

All Keithley product names are trademarks or registered trademarks of Keithley Instruments, Inc.

Other brand and product names are trademarks or registered trademarks of their respective holders.

BESCHEINIGUNG DES HERSTELLERS/IMPORTEURS

Hiermit wird bescheinigt, daas der/die/das MODEL 428 CURRENT AMPLIFIER in Uebereinstimmung mit den Bestimmungen der Vfq 1046/1984 funk-entstort ist. Der Deutschen Bundespost wurde das Inverkehrbringen dieses Gerates angezeigt und die Berechtigung zur Ueberprufung der Serie auf Einhaltung der Bestimmungen eingeräumt.

Einhaltung mit betreffenden Bestimmungen kommt darauf an, dass geschirmte Ausfuehrungen gebraucht werden. Fur die Beschaffung richtiger Ausfuehrungen ist der Betreiber verantwortlich.

DIESES GERAET WURDE SOWOHL EINZELN ALS AUCH IN EINER ANLAGE, DIE EINEN NORMALEN ANWENDUNGSFALL NACHBILDET, AUF DIE EINHALTUNG DER FUNK-ENTSTOERBESTIMMUNGEN GEPRUEFT. ES IS JEDOCH MOEGlich, DASS DIE FUNK-ENTSTOERBESTIMMUNGEN UNTER UNGUENSTIGEN UMSTAENDEN BEI ANDEREN GERAETEKOMBINATIONEN NICHT EINGEHALTEN WERDEN. FUER DIE EINHALTUNG DER FUNK-ENTSTOERBESTIMMUNGEN SEINER GESAMTEN ANLAGE, IN DER DIESES GERAET BETRIEBEN WIRD, IST DER BETREIBER VERANTWORTLICH.

Keithley Instruments, Incorporated

CERTIFICATE BY MANUFACTURER/IMPORTER

This is to certify that the MODEL 428 CURRENT AMPLIFIER is shielded against radio interference in accordance with the provisions of Vfq 1046/1984. The German Postal Services have been advised that this device is being put on the market and that they have been given the right to inspect the series for compliance with the regulations.

Compliance with applicable regulations depends on the use of shielded cables. It is the user who is responsible for procuring the appropriate cables.

THIS EQUIPMENT HAS BEEN TESTED CONCERNING COMPLIANCE WITH THE RELEVANT RFI PROTECTION REQUIREMENTS BOTH INDIVIDUALLY AND ON SYSTEM LEVEL (TO SIMULATE NORMAL OPERATION CONDITIONS). HOWEVER, IT IS POSSIBLE THAT THESE RFI REQUIREMENTS ARE NOT MET UNDER CERTAIN UNFAVORABLE CONDITIONS IN OTHER INSTALLATIONS. IT IS THE USER WHO IS RESPONSIBLE FOR COMPLIANCE OF HIS PARTICULAR INSTALLATION.

Keithley Instruments, Incorporated

Safety Precautions

The following safety precautions should be observed before using this product and any associated instrumentation. Although some instruments and accessories would normally be used with non-hazardous voltages, there are situations where hazardous conditions may be present.

This product is intended for use by qualified personnel who recognize shock hazards and are familiar with the safety precautions required to avoid possible injury. Read the operating information carefully before using the product.

The types of product users are:

Responsible body is the individual or group responsible for the use and maintenance of equipment, for ensuring that the equipment is operated within its specifications and operating limits, and for ensuring that operators are adequately trained.

Operators use the product for its intended function. They must be trained in electrical safety procedures and proper use of the instrument. They must be protected from electric shock and contact with hazardous live circuits.

Maintenance personnel perform routine procedures on the product to keep it operating, for example, setting the line voltage or replacing consumable materials. Maintenance procedures are described in the manual. The procedures explicitly state if the operator may perform them. Otherwise, they should be performed only by service personnel.

Service personnel are trained to work on live circuits, and perform safe installations and repairs of products. Only properly trained service personnel may perform installation and service procedures.

Exercise extreme caution when a shock hazard is present. Lethal voltage may be present on cable connector jacks or test fixtures. The American National Standards Institute (ANSI) states that a shock hazard exists when voltage levels greater than 30V RMS, 42.4V peak, or 60VDC are present. **A good safety practice is to expect that hazardous voltage is present in any unknown circuit before measuring.**

Users of this product must be protected from electric shock at all times. The responsible body must ensure that users are prevented access and/or insulated from every connection point. In some cases, connections must be exposed to potential human contact. Product users in these circumstances must be trained to protect themselves from the risk of electric shock. If the circuit is capable of operating at or above 1000 volts, **no conductive part of the circuit may be exposed.**

As described in the International Electrotechnical Commission (IEC) Standard IEC 664, digital multimeter measuring circuits (e.g., Keithley Models 175A, 199, 2000, 2001, 2002, and 2010) are Installation Category II. All other instruments' signal terminals are Installation Category I and must not be connected to mains.

Do not connect switching cards directly to unlimited power circuits. They are intended to be used with impedance limited sources. NEVER connect switching cards directly to AC mains. When connecting sources to switching cards, install protective devices to limit fault current and voltage to the card.

Before operating an instrument, make sure the line cord is connected to a properly grounded power receptacle. Inspect the connecting cables, test leads, and jumpers for possible wear, cracks, or breaks before each use.

For maximum safety, do not touch the product, test cables, or any other instruments while power is applied to the circuit under test. ALWAYS remove power from the entire test system and discharge any capacitors before: connecting or disconnecting cables or jumpers, installing or removing switching cards, or making internal changes, such as installing or removing jumpers.

Do not touch any object that could provide a current path to the common side of the circuit under test or power line (earth) ground. Always make measurements with dry hands while standing on a dry, insulated surface capable of withstanding the voltage being measured.

The instrument and accessories must be used in accordance with its specifications and operating instructions or the safety of the equipment may be impaired.

Do not exceed the maximum signal levels of the instruments and accessories, as defined in the specifications and operating information, and as shown on the instrument or test fixture panels, or switching card.

When fuses are used in a product, replace with same type and rating for continued protection against fire hazard.

Chassis connections must only be used as shield connections for measuring circuits, NOT as safety earth ground connections.

If you are using a test fixture, keep the lid closed while power is applied to the device under test. Safe operation requires the use of a lid interlock.

If a  screw is present, connect it to safety earth ground using the wire recommended in the user documentation.

The  symbol on an instrument indicates that the user should refer to the operating instructions located in the manual.

The  symbol on an instrument shows that it can source or measure 1000 volts or more, including the combined effect of normal and common mode voltages. Use standard safety precautions to avoid personal contact with these voltages.

The **WARNING** heading in a manual explains dangers that might result in personal injury or death. Always read the associated information very carefully before performing the indicated procedure.

The **CAUTION** heading in a manual explains hazards that could damage the instrument. Such damage may invalidate the warranty.

Instrumentation and accessories shall not be connected to humans.

Before performing any maintenance, disconnect the line cord and all test cables.

To maintain protection from electric shock and fire, replacement components in mains circuits, including the power transformer, test leads, and input jacks, must be purchased from Keithley Instruments. Standard fuses, with applicable national safety approvals, may be used if the rating and type are the same. Other components that are not safety related may be purchased from other suppliers as long as they are equivalent to the original component. (Note that selected parts should be purchased only through Keithley Instruments to maintain accuracy and functionality of the product.) If you are unsure about the applicability of a replacement component, call a Keithley Instruments office for information.

To clean the instrument, use a damp cloth or mild, water based cleaner. Clean the exterior of the instrument only. Do not apply cleaner directly to the instrument or allow liquids to enter or spill on the instrument.

SAFETY PRECAUTIONS

Although the Model 428 Current Amplifier would normally be used with non-hazardous voltages, there are situations where hazardous conditions may be present. For that reason, the following safety precautions should be observed before using the Model 428.

The Model 428 Current Amplifier is intended for use by qualified personnel who recognize shock hazards and are familiar with the safety precautions required to avoid possible injury. Read over this manual carefully before using the instrument.

Exercise extreme caution when a shock hazard is present at the instrument or test circuit. User-supplied lethal voltages may be present at the test circuit or instrument. The American National Standards Institute (ANSI) states that a shock hazard exists when voltage levels greater than 30V RMS or 42.4V peak are present. **A good safety practice is to expect that hazardous voltage is present in any unknown circuit.**

Inspect the connecting cables or test leads for possible wear, cracks, or breaks before each use.

For maximum safety, do not touch the test circuit, test cables or any instruments while power is applied to the circuit under test. Turn off all power and discharge all capacitors before connecting or disconnecting cables.

Do not touch any object which could provide a current path to the common side of the circuit under test or power line (earth) ground. Always make measurements with dry hands while standing on a dry, insulated surface capable of withstanding the voltage being measured.

Do not exceed the instrument's maximum allowable input or common mode voltage, as defined in the specifications section of this manual.

Instrumentation and accessories should not be connected to humans.

SICHERHEITSHINWEISE

Wenden Sie sich hinsichtlich ausführlicher Sicherheitsinformationen und Betriebsanweisungen an das Haupthandbuch.

Der Stromverstärker Modell 428 ist für die Benutzung durch qualifiziertes Personal bestimmt, das eine Stromschlaggefahr erkennt und mit den Sicherheitsvorkehrungen vertraut ist, die mögliche Verletzungen verhindern. Lesen Sie diese Anweisungen, bevor Sie das Gerät benutzen.

Gehen Sie mit äußerster Vorsicht vor, falls Stromschlaggefahr am Gerät- oder Teststromkreis besteht. Dieser kann u.U. mit tödlichen Spannungen versorgt sein. Das American National Standards Institute (ANSI) legt fest, daß eine Stromschlaggefahr dann besteht, wenn die Spannungswerte mehr als 30V RMS oder 42,4V Spitzenleistung betragen. Eine gute Sicherheitsvorkehrung ist daher, daß Sie in jedem unbekanntem Stromkreis eine tödliche Spannung vermuten.

Prüfen Sie die Anschlußkabel oder Prüflleitungen vor jeder Benutzung auf Abnutzung, Risse oder Brüche.

Berühren Sie aus Sicherheitsgründen weder Teststromkreise, Testkabel noch andere Instrumente, während der zu prüfende Stromkreis mit Strom versorgt wird. Stellen Sie, bevor Sie Kabel anschließen oder trennen, den Strom ab und entladen Sie alle Kondensatoren.

Berühren Sie keinen Gegenstand, der eine Stromleitung zur gemeinsamen Seite des zu prüfenden Stromkreises oder Stromleitungs(Erdung)masse darstellt. Nehmen Sie alle Messungen mit trockenen Händen vor, während Sie auf einer trockenen, isolierten Oberfläche stehen, die es Ihnen ermöglicht, die zu messende Spannung zu verkräften.

Überschreiten Sie nicht den maximal zulässigen Eingangswert oder die gemeinsame Modusspannung des Instruments, der im Kapitel Technische Daten dieses Handbuchs aufgeführt ist.

Die Instrumente und das Zubehör sollten keine Verbindung zu Menschen haben.

KONTROLLÜBERSICHT

DISPLAY INTENSITY: Bestimmt normal/dunkel/Aus bei der Anzeige.

LOCAL: Bringt Einheit in entsprechenden Modus und stellt Frontpanelastastenfunktion wieder her (nur 428-PROG).

MENU: Ermöglicht Bestimmung der Firmware Revisionsanzeige, IEEE-488 Primäradresse (428-PROG), Autofilter An/Aus, Speicher/Abrufkonfiguration und Selbstüberprüfung.

SHIFT EXIT: Beendet MENU.

ZERO CHECK: Ermöglicht Prüfung der Abweichungen und muß zur Ablesung normaler Ausgangssignale unterbrochen werden.

SHIFT CORRECT: Bedingt automatische Nullstellung der Abweichspannung des Instrumenteneingangs.

SETUP GAIN: Verwenden Sie Knopf oder Cursortasten zur Einstellung der Verstärkung (10^3V/A - 10^{10}V/A , mit X10 Verstärkung aus, 10^4V/A - 10^{11}V/A mit X10 an).

SETUP FILTER RISE TIME: Verwenden Sie Knopf oder Cursortasten zur Einstellung der Filteranstiegszeit ($10\mu\text{sec}$ - 300msec).

SETUP CURRENT SUPPRESS: Verwenden Sie Cursortasten zur Einstellung des Unterdrückungsbereiches und Cursorstellung; verwenden Sie den Knopf zur Einstellung des Stellenwertes ($\pm 0,001\text{nA}$ bis $\pm 5\text{mA}$).

SHIFT AUTO: Automatische Stromunterdrückung.

SETUP VOLTAGE BIAS: Verwenden Sie die Cursortasten zur Stellenwahl; drehen Sie den Knopf zur Wahl des Stellenwertes ($\pm 5\text{V}$).

ENABLE keys: An-/Ausschalten entsprechender Funktion (integrierte LED-Anzeige weist auf An-Stellung hin).

GEBRÄUCLICHE ANSCHLÜSSE

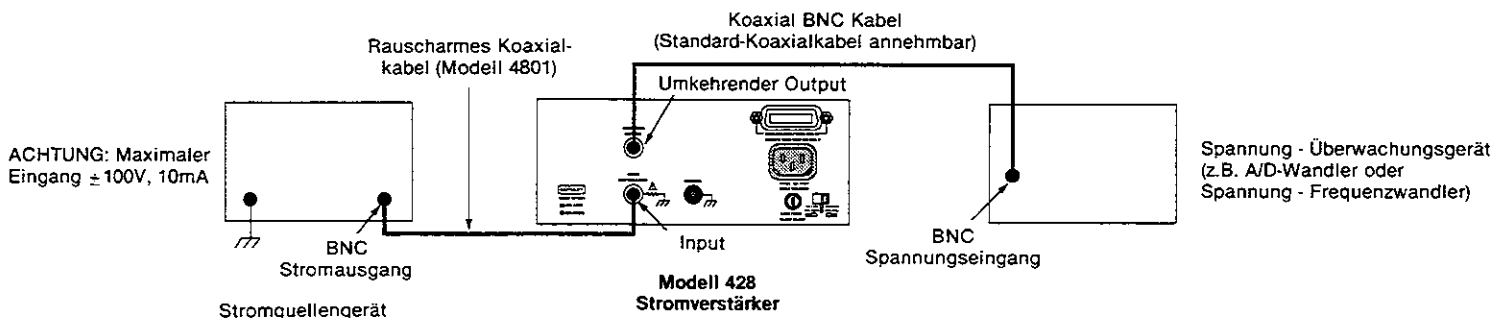

CONSIGNES DE SÉCURITÉ

Veillez vous reporter au manuel principal qui contient tous les renseignements sur les consignes de sécurité ainsi que les directives d'utilisation.

L'amplificateur de courant modèle 428 est destiné à des spécialistes conscients des dangers électriques et connaissant les mesures de prévention à prendre pour éviter tout risque de blessures. Veuillez lire attentivement ce manuel avant d'utiliser l'instrument.

Redoublez de précautions lorsqu'il existe un risque de secousse électrique au niveau de l'instrument ou du circuit d'essais. Des tensions mortelles pour l'utilisateur risquent d'être présentes au niveau du circuit d'essais ou de l'instrument. Selon l'institut américain des normes, l'American National Standards Institute (ANSI), il existe un risque de secousse électrique lorsque le niveau de la tension dépasse 30 V efficaces ou 42,4 V de tension crête. Il est toujours prudent de considérer qu'une tension dangereuse est présente dans tout circuit inconnu.

Examiner l'état des câbles de connexion ou les cordons d'essais pour s'assurer qu'ils ne présentent ni usure, ni craquelures, ni fissures avant chaque essai.

Pour un maximum de sécurité, ne pas toucher le circuit d'essais, les câbles d'essais, ni aucun instrument lorsque le montage en cours d'essai est sous tension. Couper l'alimentation en courant et décharger tous les condensateurs avant de brancher ou de débrancher des câbles.

Ne toucher aucun objet susceptible de fournir un chemin conducteur vers le côté commun du circuit en cours d'essai ou la terre (masse) du circuit d'alimentation. Ne faire des mesures qu'avec des mains sèches en étant sur un sol sec, isolé capable de réaliser l'isolation des tensions mesurées.

Ne pas dépasser la tension maximale d'entrée ou la tension de mode commun à l'entrée de l'instrument, comme définie au chapitre caractéristiques de ce manuel.

Instruments et accessoires ne doivent pas être raccordés à des personnes.

SCHEMA TYPE DE BRANCHEMENT

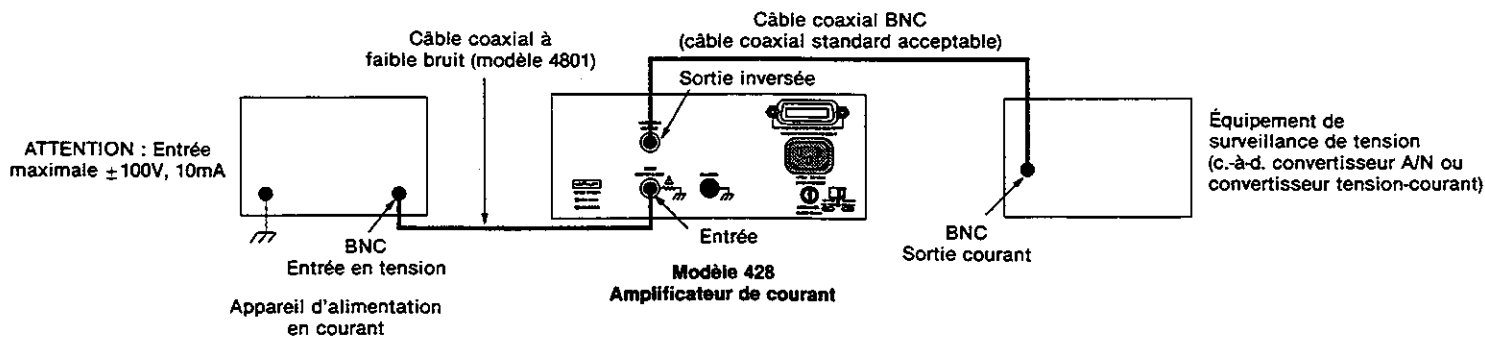

RÉSUMÉ DES COMMANDES

INTENSITÉ D'AFFICHAGE (DISPLAY INTENSITY) : Permet de sélectionner : normal/faible/pas d'affichage.

COMMANDE DIRECTE (LOCAL) : Permet de commander directement l'appareil et remet en fonctionnement les touches du panneau d'affichage (uniquement 428-PROG).

MENU : Permet de sélectionner l'affichage de la révision du matériel, l'adresse primaire IEEE-4888 (428-PROG), MARCHÉ/ARRÊT du filtre automatique, la mise en mémoire et le rappel de la configuration ainsi que le dispositif de contrôle automatique.

TOUCHE MAJUSCULE - SORTIE (SHIFT EXIT) : Permet de sortir du menu.

VÉRIFICATION DU ZÉRO (ZERO CHECK) : Permet la vérification des décalages, et doit être inhibée pour obtenir le signal normal de sortie.

TOUCHE MAJUSCULE - CORRECTION (SHIFT CORRECT) : Réalise la mise à zéro automatique pour annuler la tension décalée d'entrée de l'instrument.

SÉLECTION DU GAIN (SETUP GAIN) : Utilise le bouton ou les touches du curseur pour régler le gain ($10^3V/A$ - $10^{10}V/A$ avec gain X10 invalidé, $10^4V/A$ à $10^{11}V/A$ avec le gain X10 validé).

SÉLECTION DU TEMPS DE MONTÉE DU FILTRE (SETUP FILTER RISE TIME) : Utiliser les touches du curseur pour sélectionner le temps de montée du filtre ($10\mu s$ à 300ms).

SÉLECTION DE LA SUPPRESSION DE COURANT (SETUP CURRENT SUPPRESS) : Utiliser les touches du curseur pour sélectionner la gamme de courant à supprimer et la position du curseur, utiliser le bouton de réglage pour régler le coefficient du chiffre ($\pm 0,001nA$ à $\pm 5mA$).

TOUCHE MAJUSCULE - AUTO (SHIFT AUTO) : Permet la suppression automatique du courant.

SÉLECTION DE LA TENSION DE POLARISATION (SETUP VOLTAGE BIAS) : Utiliser les touches curseur pour sélectionner le nombre de chiffres, tourner le bouton de réglage pour afficher la valeur ($\pm 5V$).

TOUCHES DE VALIDATION (ENABLE) : Permet de valider ou d'invalider la fonction correspondante (la LED de l'appareil indique si la fonction est validée).

NORME DI SICUREZZA

Fate riferimento al manuale principale per maggiori dettagli sulle norme di sicurezza e le istruzioni per l'uso.

L'amplificatore di corrente modello 428 è stato progettato ad uso di personale qualificato, a conoscenza del rischio di scossa elettrica ed avente familiarità con le precauzioni necessarie per evitare ogni danno possibile a persone e cose. Leggete attentamente questo manuale prima di utilizzare lo strumento.

Prestate estrema attenzione in situazioni in cui è presente il rischio di scossa elettrica sullo strumento o nel circuito di prova, in quanto è possibile che vi si rilevino tensioni considerate letali impresse dall'utente. L'ANSI (American National Standard Institute) riconosce il rischio di scossa elettrica in presenza di tensioni di picco maggiori di 30V RSM o 42,4V. È buona norma considerare presenti tensioni pericolose in ogni circuito elettrico sconosciuto.

Controllate i cavi di connessione ed i contatti prima dell'uso per evitare problemi creati da usura, crepe o rotture.

Per maggior sicurezza, non toccate il circuito ed i cavi di prova, o un qualsiasi altro strumento una volta applicata corrente al circuito di prova. Disinserite l'alimentazione e scaricate tutti i condensatori prima di connettere o sconnettere i cavi.

Non toccate alcun oggetto che possa consentire passaggio di corrente al lato comune del circuito in prova o alla massa (terra) della linea di tensione. Eseguite tutte le misurazioni con le mani asciutte, stando su una superficie isolata ed in grado di sopportare l'entità di tensione misurata.

Non superate l'ingresso di tensione massimo o modo comune consentito, come specificato nell'apposito capitolo di questo manuale.

Nè gli strumenti nè gli accessori devono essere connessi agli esseri umani.

RIASSUNTO DEI COMANDI

INDICATORE INTENSITÀ (DISPLAY INTENSITY): Permette la selezione della chiarezza luminosità dell'indicatore tra normale/chiaro/spento.

LOCALE (LOCAL): Pone il dispositivo in uso locale e ripristina l'operatività del pannello a tasti (solo 428-PROG).

MENU: Consente la selezione dell'indicatore di revisione firmware, indirizzo primario IEEE-488 (428-PROG), filtro automatico on/off, configurazione save/recall e test automatico.

SHIFT EXIT: Esce dal menu.

CONTROLLO RIPRISTINO (ZERO CHECK): Consente il controllo degli offset, e deve essere disinserito per ottenere un segnale normale in uscita.

CORREZIONE SHIFT (SHIFT CORRECT): Effettua automaticamente una correzione di ripristino per annullare la tensione di offset dello strumento.

SELEZIONE GUADAGNO (SETUP GAIN): Usate la manopola o i tasti cursori per stabilire il guadagno (10^3V/A - 10^{10}V/A , con guadagno off X10, 10^4V/A - 10^{11}V/A con guadagno on X10).

SELEZIONE TEMPO DI SALITA FILTRO (SETUP FILTER RISE TIME): Usate la manopola o i tasti cursori per scegliere il tempo di salita del filtro (10 μsec -300 msec).

SOPPRESSIONE CORRENTI (SETUP CURRENT SUPPRESS): Usate i tasti cursori la gamma di correnti da sopprimere e la posizione del cursore; usate la manopola per modificare i valori ($\pm 0,001\text{nA}$ a $\pm 5\text{mA}$).

SHIFT AUTO: Elimina automaticamente la corrente.

SELEZIONE DELLA TENSIONE DI POLARIZZAZIONE (SETUP VOLTAGE BIAS): Usate i tasti cursori per scegliere le cifre, ruotate la manopola per sceglierne il valore ($\pm 5\text{V}$).

Tasti di ATTIVAZIONE (ENABLE): Attivano/disattivano la rispettiva funzione (la spia indica quando una funzione è attivata).

CONNESSIONI TIPICHE

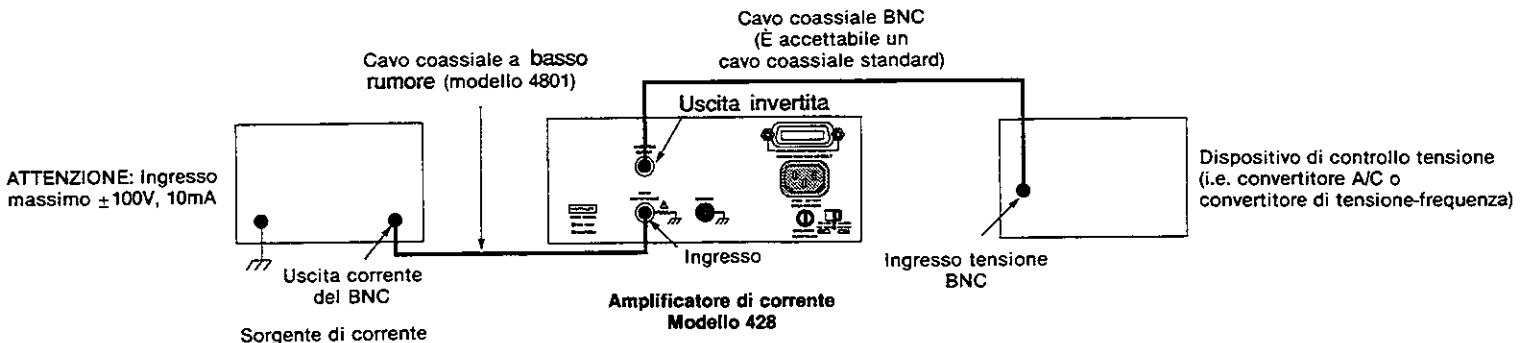

安全についての注意

安全性および操作方法の詳細については、本マニュアルのそれぞれの章を参照してください。

モデル428 カレント・アンプ(電流増幅器)は、電気ショックの危険を認識でき、予想される負傷を避けるために必要な安全対策に精通している方が使用してください。ご使用になる前に、本マニュアルをよくお読みください。

装置またはテスト回路に電気ショックが存在する場合、十二分の注意を払ってください。使用者によって供給される致命的な電圧がテスト回路または装置に存在することがあります。American National Standards Institute (ANSI) (米国標準協会)では、電圧が30V RMS以上またはピークが42.4Vの状態において電気ショックが存在する、と示しています。最良の安全対策は、どの回路にも危険な電圧が存在すると考えることです。

毎回使用する前に、接続ケーブルを検査または導線の摩耗、亀裂、破損がないかどうかを検査します。

テスト中、電圧が回路に与えられている間、テスト回路およびテスト・ケーブル、装置には絶対に触れないでください。ケーブルの接続または取り外し前に、電圧の供給を遮断し、すべてのコンデンサーを放電します。

テスト中の回路のコモン側またはアースへの電流の道を提供するような部分には絶対に触れないでください。計測される電圧に耐え得る乾燥した絶縁した床の上に立ち、乾いた手で計測することを常に心がけてください。

本マニュアルに記載されている装置の最大許容入力またはコモン・モード電圧を超えないでください。

機器および付属品は人体に接続しないでください。

操作方法の要約

表示明度 (DISPLAY INTENSITY): 標準 / 弱 / 切 から選択します。

ローカル (LOCAL): ユニートをローカルに設置し、フロントパネルのキー操作を回復します。(428-PROG)

メニュー (MENU): ファームウェア・リビジョン表示、IEEE-448 主要アドレス (428-PROG)、自動フィルターのオン / オフ、保存 / 再呼出の構築、そしてセルフ・テストから選択します。

シフト・イグジット (SHIFT EXIT): メニューから抜けます。

ゼロ・チェック (ZERO CHECK): オフセットのチェックします。ノーマル出力信号を得るためには無効にします。

シフト・コレクト (SHIFT CORRECT): ヌル装置入力オフセット電圧に対して自動ゼロ修正を行います。

セットアップ・ゲイン (SETUP GAIN): ノブまたはカーソル・キーを使ってゲインを設定します。(X10ゲイン・オフで10V/Aから10V/A。X10ゲイン・オンで10V/Aから10V/A)

セットアップ・フィルター・ライズ・タイム (SETUP FILTER RISE TIME): ノブまたはカーソル・キーを使ってフィルター・ライズ・タイムを設定します (10 マイクロ秒から300 ミリ秒)。

セットアップ・カレント・サプレッス (SETUP CURRENT SUPPRESS): カーソル・キーを使って抑制レンジとカーソル位置を選択し、ノブを使って数値を調整します ($\pm 0.0001\text{nA}$ から $\pm 5\text{mA}$)。

シフト・オート (SHIFT AUTO): 自動電流抑制を行います。

セットアップ・ボルテージ・バイアス (SETUP VOLTAGE BIAS): カーソル・キーを使って数値を選択し、ノブを使って調節します ($\pm 5\text{V}$)。

エナブル・キー (ENABLE): 有効 / 無効の切り替えを行います (有効のときはLED表示が点灯します)。

典型的な接続

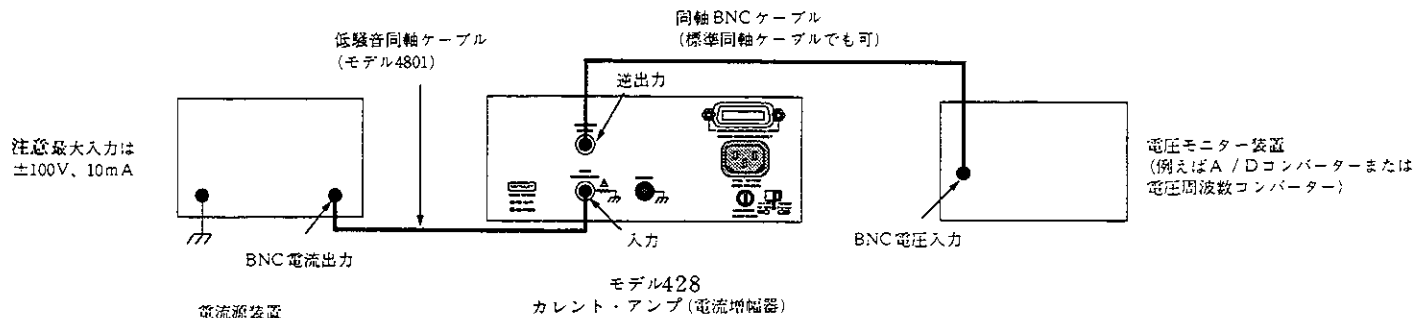

SAFETY WARNINGS

Refer to main manual for detailed safety information and complete operating instructions.

The Model 428 Current Amplifier is intended for use by qualified personnel who recognize shock hazards and are familiar with the safety precautions required to avoid possible injury. Read over this manual carefully before using the instrument.

Exercise extreme caution when a shock hazard is present at the instrument or test circuit. User-supplied lethal voltages may be present at the test circuit or instrument. The American National Standards Institute (ANSI) states that a shock hazard exists when voltage levels greater than 30V RMS or 42.4V peak are present. **A good safety practice is to expect that hazardous voltage is present in any unknown circuit.**

Inspect the connecting cables or test leads for possible wear, cracks, or breaks before each use.

For maximum safety, do not touch the test circuit, test cables or any instruments while power is applied to the circuit under test. Turn off all power and discharge all capacitors before connecting or disconnecting cables.

Do not touch any object which could provide a current path to the common side of the circuit under test or power line (earth) ground. Always make measurements with dry hands while standing on a dry, insulated surface capable of withstanding the voltage being measured.

Do not exceed the instrument's maximum allowable input or common mode voltage, as defined in the specifications section of this manual.

Instrumentation and accessories should not be connected to humans.

CONTROL SUMMARY

DISPLAY INTENSITY: Selects normal/dim/off display.

LOCAL: Places unit in local and restores front panel key operation (428-PROG only).

MENU: Allows selection of firmware revision display, IEEE-488 primary address (428-PROG), autofilter on/off, save/recall configuration, and self-test.

SHIFT EXIT: Exits MENU.

ZERO CHECK: Allows check of offsets, and must be disabled to obtain normal output signal.

SHIFT CORRECT: Performs automatic zero correction to null instrument input offset voltage.

SETUP GAIN: Use knob or cursor keys to set gain (10^3V/A – 10^{10}V/A , with X10 gain off, 10^4V/A – 10^{11}V/A , with X10 gain on).

SETUP FILTER RISE TIME: Use knob or cursor keys to select filter rise time (10 μsec –300msec).

SETUP CURRENT SUPPRESS: Use cursor keys to select suppress range and cursor position; use knob to adjust digit value ($\pm 0.001\text{nA}$ to $\pm 5\text{mA}$).

SHIFT AUTO: Performs automatic current suppression.

SETUP VOLTAGE BIAS: Use cursor keys to select digit; rotate knob to select digit value ($\pm 5\text{V}$).

ENABLE keys: Enable/disable respective function (integral LED indicates when function is enabled).

TYPICAL CONNECTIONS

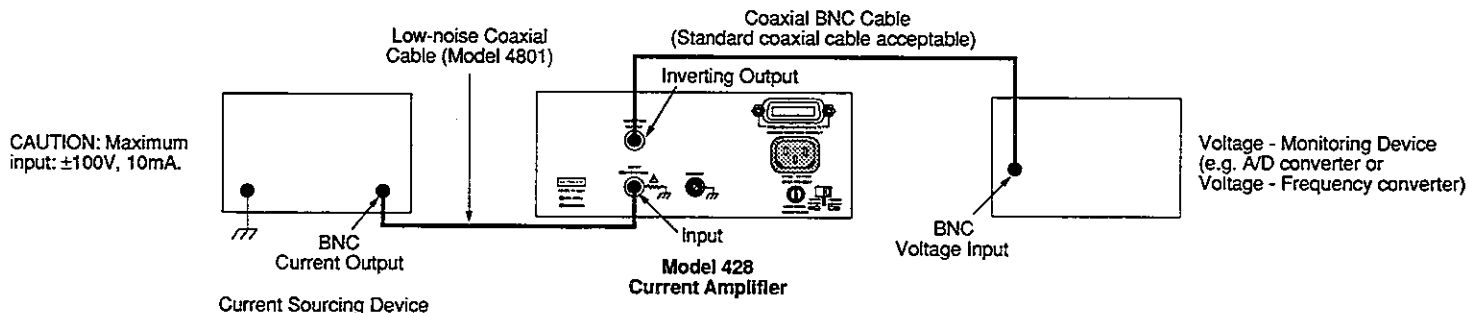

ADVERTENCIAS DE SEGURIDAD

Remitirse al manual principal para información detallada de seguridad e instrucciones completas de funcionamiento.

Se pretende que el Amplificador de Corriente Modelo 428 sea para ser usado por personal calificado que conoce los peligros de choque y está familiarizado con las precauciones de seguridad requeridas para evitar posibles lesiones. Leer este manual cuidadosamente antes de usar el instrumento.

Tener sumo cuidado cuando existe la posibilidad de choque eléctrico en el instrumento o circuito de prueba. Pueden haber voltajes mortales provenientes del usuario en el circuito de prueba o el instrumento. El Instituto Nacional Americano de Normas (ANSI) expone que existe un peligro de choque cuando hay presentes niveles de voltaje de más de 30 V efectivo ó 42,4 V máx. Una buena práctica de seguridad es la de esperar que existan voltajes peligrosos en cualquier circuito desconocido.

Inspeccionar para ver si existen roturas o desgastes en los cables de conexión o conductores de pruebas, antes de cada uso.

Para seguridad máxima, no tocar el circuito de prueba, los conductores de prueba ni ningún instrumento mientras la energía esté aplicada al circuito bajo prueba. Desconectar toda la energía y descargar todos los condensadores antes de conectar o desconectar los cables.

No tocar ningún objeto, el cual pueda facilitar un camino de la corriente hacia el lado común del circuito bajo prueba o la tierra de la línea de energía. Realizar siempre las mediciones con las manos secas mientras se está parado en una superficie seca y aislada capaz de soportar el voltaje que se está midiendo.

No exceder la entrada máxima permitida o el voltaje del común del instrumento, según lo definido en la sección de especificaciones de este manual.

Ni la instrumentación ni los accesorios deben ser conectados a personas.

SUMARIO DE CONTROL

INTENSIDAD DE PANTALLA (DISPLAY INTENSITY): Selecciona pantalla normal/tenue/apagado.

LOCAL: Pone la unidad en local y restaura la operación de botones del frente del tablero (sólo 428-PROG).

MENU: Permite la selección de pantalla de revisión de soporte lógico inalterable ("firmware"), dirección primaria IEEE-488 (428-PROG), conexión/desconexión de auto filtrado, configuración de guardar/recuperar y auto-prueba.

SHIFT EXIT: Para salir del MENU.

COMPROBACION DE CERO (ZERO CHECK): Permite comprobación de desplazamientos, y debe ser inhabilitado para obtener señal de salida normal.

SHIFT CORRECT: Realiza corrección automática de cero para balancear el voltaje de desplazamiento de entrada del instrumento.

AJUSTE DE GANANCIA (SETUP GAIN): Usar la perilla o botones del cursor para ajustar la ganancia (10^3 V/A- 10^{10} V/A, con ganancia x10 inactiva; 10^4 V/A- 10^{11} V/A, con ganancia x10 activa).

AJUSTE DE TIEMPO DE ELEVACION DE FILTRO (SETUP FILTER RISE TIME): Usar la perilla o botones del cursor para seleccionar el tiempo de elevación del filtro ($10 \mu\text{seg.}$ -300 mseg.).

AJUSTE DE SUPRESION DE CORRIENTE (SETUP CURRENT SUPPRESS): Usar los botones del cursor para seleccionar la gama de supresión y la posición del cursor; usar la perilla para ajustar el valor digital $\pm 0,001$ nA a ± 5 mA).

CAMBIO AUTOMATICO (SHIFT AUTO): Realiza supresión automática de corriente.

AJUSTE DE VOLTAJE DE POLARIZACION (SETUP VOLTAGE BIAS): Usar los botones del cursor para seleccionar dígito; hacer girar la perilla para seleccionar el valor del dígito (± 5 V).

Teclas de HABILITAR (ENABLE): Habilitan/inhabilitan las funciones respectivas (luminodiodeo (LED) integral indica qué función está habilitada).

CONEXIONES TICAS

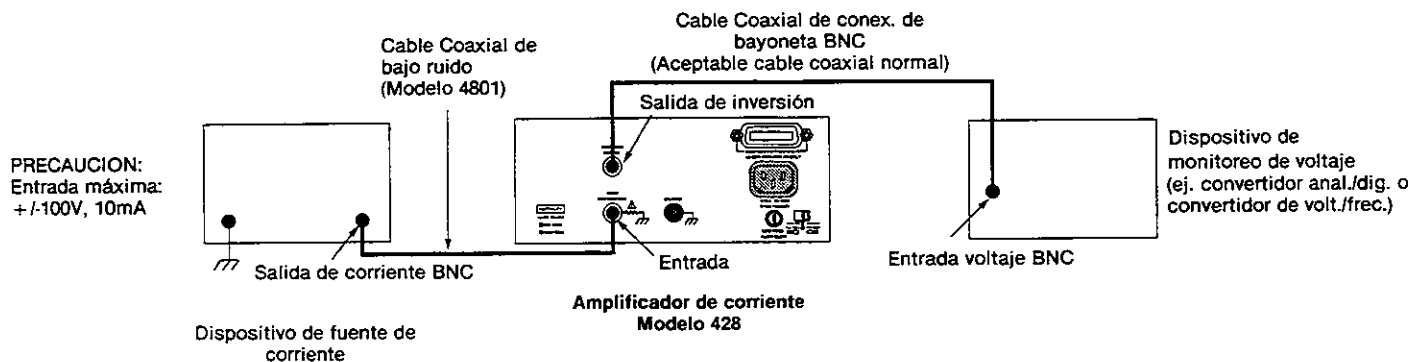

SPECIFICATIONS

428 SPECIFICATIONS

GAIN SETTING V/A	ACCURACY ¹		LOW NOISE ²		MAXIMUM SPEED		DC INPUT RESISTANCE
	18°-28°C	TEMPERATURE COEFFICIENT	RISE TIME	NOISE	RISE TIME	NOISE	
	±(% input + offset)	±(% input + offset)/°C	(10%-90%) msec	RMS	(10%-90%) μsec ³	RMS ³	
10 ³	0.45 + 1.2 μA	0.01 + 40 nA	0.1	90 nA	2	100 nA	< 0.6 Ω
10 ⁴	0.31 + 120 nA	0.01 + 4 nA	0.1	9 nA	2	15 nA	< 0.7 Ω
10 ⁵	0.31 + 12 nA	0.01 + 400 pA	0.1	900 pA	5	2 nA	< 1.6 Ω
10 ⁶	0.34 + 1.2 nA	0.01 + 40 pA	0.1	90 pA	10	500 pA	< 10 Ω
10 ⁷	0.5 + 122 pA	0.015 + 4.3 pA	0.1	9 pA	15	200 pA	< 100 Ω
10 ⁸	1.4 + 14 pA	0.015 + 700 fA	1	0.5 pA	40	30 pA	< 1 kΩ
10 ⁹	2.5 + 3 pA	0.025 + 300 fA	10	50 fA	100	10 pA	< 10 kΩ
10 ¹⁰	2.5 + 1.6 pA	0.025 + 250 fA	100	4 fA	250	2 pA	< 100 kΩ
10 ^{11*}	2.7 + 1.6 pA	0.028 + 250 fA	300	1.2 fA	250	2 pA	< 100 kΩ

¹ When properly zeroed using zero correct.

² Selectable filtering will improve noise specifications; see operator's manual for details (typical value shown).

³ With up to 100pF shunt capacitance; autofilter on; low pass filter off.

* 10¹¹ setting is 10¹⁰ setting with GAIN ×10 enabled; other entries are for GAIN ×10 disabled.

INPUT:

Voltage Burden: <200μV (18°-28°C) for inputs <100μA; <10mV for 10mA input; 20μV/°C temperature coefficient.

Maximum Overload: 100V on 10⁴ to 10¹¹V/A ranges; 10V on 10²V/A range. Higher voltage sources must be current limited at 10mA.

OUTPUT:

Range: ±10V, 1mA; bias voltage off.

Impedance: <100Ω DC-175kHz.

LOW PASS FILTER:

Ranges: 10μsec. to 300msec. (±25%) in 1, 3, 10 sequence or OFF.

Attenuation: 12dB/octave.

GAIN ×10: Rise time, noise, and input resistance are unchanged when selecting GAIN ×10; gain accuracy and temperature coefficient are degraded by 0.2% and 0.003%/°C respectively.

CURRENT SUPPRESSION:

RANGE	RESOLUTION	ACCURACY ±(% setting + offset)
±5 nA	1 pA	3.0 + 10 pA
±50 nA	10 pA	1.6 + 100 pA
±500 nA	100 pA	0.8 + 1 nA
±5 μA	1 nA	0.7 + 10 nA
±50 μA	10 nA	0.6 + 100 nA
±500 μA	100 nA	0.6 + 1 μA
±5 mA	1 μA	0.6 + 10 μA

BIAS VOLTAGE:

Range: ±5V.

Resolution: 2.5mV.

Accuracy: ±(1.1%rdg + 25mV).

IEEE-488 BUS IMPLEMENTATION (428-PROG ONLY)

MULTILINE COMMANDS: DCL, LLO, SDC, GTL, UNT, UNL, SPE, SPD.

UNILINE COMMANDS: IPC, REN, EOI, SRQ, ATN.

INTERFACE FUNCTIONS: SH1, AH1, T6, L4, LED, SR1, RL1, PP0, DC1, DT0, C0, EI.

PROGRAMMABLE PARAMETERS: All parameters and controls programmable except for IEEE-488 bus address.

EXECUTION SPEED: (measured from DAV true to RFD true on bus)

Zero correct and autosuppression commands: <3 sec.

Save/Recall Configuration commands: <500 msec.

All other commands: <40 msec.

GENERAL

DISPLAY: Ten character alphanumeric LED display with normal/dim/off intensity control.

REAR PANEL CONNECTORS:

Input BNC: Common connected to chassis through 1kΩ.

Output BNC: Common connected to chassis.

IEEE-488 Connector: 428-PROG only.

5-Way Binding Post: Connected to chassis.

WARM-UP: 1 hour to rated accuracy.

ENVIRONMENT: Operating: 0°-50°C, <70% R.H. up to 35°C; linearly derate R.H. 3%/°C up to 50°C. Storage: -25°C to 65°C.

POWER: 105-125 VAC or 210-250 VAC, switch selected. (90-110/180-220 VAC available.) 50Hz or 60Hz. 45VA maximum.

DIMENSIONS, WEIGHT: 90mm high × 213mm wide × 397mm deep (3½ in. × 8½ in. × 15½ in.). Net weight 3.4kg (7.4 lbs.).

ACCESSORIES SUPPLIED: Instruction Manual, Quick Reference Guide, power line cord.

Contains information on Model 428 features, specifications, and accessories.

SECTION 1

General Information

Covers introductory information on using the Model 428 from the front panel and over the IEEE-488 bus (Model 428-PROG only).

SECTION 2

Getting Started

Supplies in-depth information about using the Model 428 from the front panel.

SECTION 3

Front Panel Operation

Details IEEE-488 information, including general commands and device-dependent commands. Section 4 applies only to the Model 428-PROG.

SECTION 4

IEEE-488 Reference

Outlines the verification procedures for checking current-to-voltage conversion accuracy and the functionality of the suppress and voltage bias circuits.

SECTION 5

Performance Verification

Gives a detailed discussion of the various circuits within the instrument.

SECTION 6

Theory of Operation

Covers such important service information as fuse replacement, adjustments, and troubleshooting.

SECTION 7

Service Information

Lists replacement parts and covers how to obtain parts.

SECTION 8

Replaceable Parts

Table of Contents

SECTION 1 — General Information

1.1	INTRODUCTION	1-1
1.2	AVAILABLE MODELS	1-1
1.3	FEATURES	1-1
1.4	WARRANTY INFORMATION	1-1
1.5	MANUAL ADDENDA	1-1
1.6	SAFETY SYMBOLS AND TERMS	1-2
1.7	SPECIFICATIONS	1-2
1.8	UNPACKING AND INSPECTION	1-2
1.8.1	Inspection for Damage	1-2
1.8.2	Shipment Contents	1-2
1.8.3	Instruction Manual	1-2
1.9	REPACKING FOR SHIPMENT	1-2
1.10	OPTIONAL ACCESSORIES	1-2

SECTION 2 — Getting Started

2.1	INTRODUCTION	2-1
2.2	FRONT AND REAR PANEL CONFIGURATION	2-1
2.3	BASIC FRONT PANEL OPERATION	2-4
2.4	BASIC IEEE-488 OPERATION	2-5

SECTION 3 — Front Panel Operation

3.1	INTRODUCTION	3-1
3.2	POWER-UP PROCEDURE	3-1
3.2.1	Line Voltage Selection	3-1
3.2.2	Line Power Connections	3-1
3.2.3	Power-up Sequence	3-2
3.2.4	Default Conditions	3-2
3.3	DISPLAY MESSAGES	3-2
3.4	INPUT/OUTPUT CONNECTIONS	3-4
3.4.1	Input Connections	3-4
3.4.2	Output Connections	3-4
3.4.3	Cable Capacitance	3-4
3.4.4	Current-to-Voltage Conversion Polarity	3-4
3.4.5	Maximum Input Current without Overload	3-7
3.5	DATA ENTRY	3-8
3.5.1	Adjust Knob and Cursor Key Operation	3-8
3.5.2	Data ENTRY EXAMPLES Examples	3-9
3.6	GAIN	3-9
3.6.1	Setting the Gain	3-9

3.6.2	X10 Gain	3-9
3.7	CURRENT SUPPRESSION	3-10
3.7.1	Suppress Error Messages	3-10
3.7.2	Programming Current Suppression	3-10
3.7.3	Enabling Current Suppression	3-10
3.7.4	Manual Suppression Procedure	3-10
3.7.5	Auto Suppression	3-11
3.8	FILTER	3-11
3.8.1	Auto-Filter	3-11
3.8.2	Filter Rise Time	3-11
3.8.3	Enabling the Filter	3-12
3.8.4	Frequency Response	3-12
3.8.5	Optimum Gain/Filter Selection	3-17
3.9	VOLTAGE BIAS	3-18
3.9.1	Voltage Bias Setup	3-18
3.9.2	Enabling Voltage Bias	3-18
3.10	ZERO CHECK AND ZERO CORRECT	3-18
3.10.1	Zero Check	3-18
3.10.2	Zero Correct	3-19
3.11	MENU SELECTION	3-19
3.11.1	Software Revision	3-19
3.11.2	IEEE-488 Primary Address	3-19
3.11.3	Auto Filter	3-20
3.11.4	Save/Recall Configuration	3-20
3.11.5	Self-test	3-21
3.12	DISPLAY INTENSITY	3-21
3.13	MEASUREMENT CONSIDERATIONS	3-21
3.13.1	Source Resistance	3-21
3.13.2	Source Capacitance	3-22
3.13.3	Mechanically-Induced Noise	3-23
3.13.4	Cable Noise Currents	3-23
3.13.5	Leakage Resistance	3-23
3.13.6	Shielding	3-24
3.13.7	Radio Frequency Interference	3-24
3.13.8	Ground Loops	3-24
3.14	APPLICATIONS	3-25
3.14.1	High-Speed Capacitor Leakage Tests	3-25
3.14.2	Current Waveform Acquisition	3-28
3.14.3	Using the Model 428 as a Picoammeter	3-29

SECTION 4 — IEEE-488 Reference

4.1	INTRODUCTION	4-1
4.2	DEVICE-DEPENDENT COMMAND PROGRAMMING	4-1
4.2.1	A — Display Intensity	4-7
4.2.2	B — Voltage Bias On/Off	4-8
4.2.3	C — Zero Check and Zero Correct	4-9
4.2.4	D — Display Message	4-10

4.2.5	H — Hit Button	4-11
4.2.6	J — Self-test	4-12
4.2.7	K — EOI and Bus Hold-Off	4-13
4.2.8	L — Save/Recall Configuration	4-14
4.2.9	M — SRQ Mask and Serial Poll Byte Format	4-15
4.2.10	N — Suppression On/Off, Automatic Suppression	4-18
4.2.11	P — Filter On/Off	4-19
4.2.12	R — Select Gain	4-20
4.2.13	S — Current Suppress Value and Range	4-21
4.2.14	T — Filter Rise Time	4-23
4.2.15	U — Default and Alternate Output	4-24
4.2.16	V — Voltage Bias Value	4-29
4.2.17	W — X10 Gain Off/On	4-30
4.2.18	X — Execute	4-31
4.2.19	Y — Terminator	4-32
4.2.20	Z — Auto-Filter On/Off	4-33
4.3	GENERAL BUS COMMANDS	4-34
4.3.1	REN (Remote Enable)	4-34
4.3.2	IFC (Interface Clear)	4-34
4.3.3	LLO (Local Lockout)	4-35
4.3.4	GTL (Go To Local) and Local	4-35
4.3.5	DCL (Device Clear)	4-35
4.3.6	SDC (Selective Device Clear)	4-35
4.3.7	SPE, SPD (Serial Polling)	4-35
4.4	PRIMARY ADDRESS PROGRAMMING	4-36
4.5	FRONT PANEL ASPECTS OF IEEE-488 OPERATION	4-36
4.5.1	Front Panel Messages	4-36
4.5.2	IEEE-488 Status Indicators	4-38
4.5.3	LOCAL Key	4-38
4.6	BUS CONNECTIONS	4-38
4.6.1	Recommended Cables	4-38
4.6.2	Typical Connections	4-38
4.6.3	Bus Limitations	4-39
4.6.4	Contact Designations	4-39

SECTION 5 — Performance Verification

5.1	INTRODUCTION	5-1
5.2	ENVIRONMENTAL CONDITIONS	5-1
5.3	INITIAL CONDITIONS	5-1
5.4	RECOMMENDED TEST EQUIPMENT	5-1
5.5	VERIFICATION PROCEDURES	5-2
5.5.1	Gain Accuracy	5-2
5.5.2	Voltage Bias Accuracy Check	5-4
5.5.3	Current Suppression Accuracy Check	5-5

SECTION 6 — Theory of Operation

6.1	INTRODUCTION	6-1
6.2	BLOCK DIAGRAM	6-1
6.3	ANALOG CIRCUITS	6-1
6.3.1	Analog Block Diagram	6-1

6.3.2	Input Amplifier	6-4
6.3.3	Differential Amplifier	6-8
6.3.4	Filter	6-9
6.3.5	Current Suppression	6-10
6.3.6	Voltage Bias	6-13
6.3.7	Zero-crossing and Overload Detectors	6-14
6.3.8	Analog Control Circuits	6-15
6.4	DIGITAL CIRCUITS	6-17
6.4.1	Digital Block Diagram	6-17
6.4.2	Microcomputer	6-17
6.4.3	Display/Keyboard	6-21
6.4.4	IEEE-488 Interface	6-22
6.5	POWER SUPPLIES	6-22
6.5.1	AC Line Input	6-23
6.5.2	+15V Supplies	6-23
6.5.3	+5V Supply	6-23
6.5.4	+6.5V Supply	6-23

SECTION 7 — Service Information

7.1	INTRODUCTION	7-1
7.2	LINE FUSE REPLACEMENT	7-1
7.3	HANDLING AND CLEANING PRECAUTIONS	7-1
7.4	SPECIAL HANDLING OF STATIC- SENSITIVE DEVICES	7-2
7.5	ADJUSTMENTS	7-2
7.5.1	Recommended Test Equipment	7-2
7.5.2	Environmental Conditions	7-4
7.5.3	Initial Conditions	7-4
7.5.4	Adjustment Locations	7-4
7.5.5	Output Offset Adjustment	7-4
7.5.6	Rise Time Adjustments	7-5
7.6	DISASSEMBLY	7-7
7.6.1	Cover Removal	7-7
7.6.2	Shield Removal	7-7
7.6.3	Front Panel Removal	7-7
7.6.4	Circuit Board Removal	7-9
7.7	TROUBLESHOOTING	7-9
7.7.1	Recommended Troubleshooting Equipment	7-9
7.7.2	Self-test	7-9
7.7.3	Troubleshooting Procedures	7-9

7.8	10 ⁸ – 10 ¹⁰ GAIN RESISTOR REPLACEMENT	7-14
-----	--	------

SECTION 8 — Replaceable Parts

8.1	INTRODUCTION	8-1
8.2	PARTS LISTS	8-1
8.3	ORDERING INFORMATION	8-1
8.4	FACTORY SERVICE	8-1
8.5	COMPONENT LAYOUTS AND SCHEMATIC DIAGRAMS	8-1

APPENDICES

APPENDIX A — Device-dependent Command Summary	A-1
APPENDIX B — Interface Function Codes	B-1
APPENDIX C — ASCII Character Codes and IEEE-488 Multiline Interface Command Messages ...	C-1
APPENDIX D — Controller Programs	D-1
APPENDIX E — IEEE-488 Bus Overview	E-1
APPENDIX F — Typical Response Curves	F-1
APPENDIX G — Bus Hold-off Times	G-1

List of Illustrations

SECTION 2 — Getting Started

Figure 2-1	Model 428 Front Panel	2-2
Figure 2-2	Model 428 Rear Panel	2-3
Figure 2-3	Typical Input/Output Connections	2-5

SECTION 3 — Front Panel Operation

Figure 3-1	INPUT Connector	3-4
Figure 3-2	Typical Input Connections	3-5
Figure 3-3	INVERTING OUTPUT Connector	3-5
Figure 3-4	Typical Output Connections	3-6
Figure 3-5	Current Input Range	3-7
Figure 3-6	Rise Time Definition	3-12
Figure 3-7	Typical Combined Response	3-14
Figure 3-8	Typical 10 μ sec Filter Response	3-14
Figure 3-9	Typical 100 μ sec Filter Response	3-15
Figure 3-10	Typical 1msec Filter Response	3-15
Figure 3-11	Typical 10msec Filter Response	3-16
Figure 3-12	Typical 100msec Filter Response	3-16
Figure 3-13	Voltage Bias Polarity	3-18
Figure 3-14	Simplified Model of Input Amplifier	3-22
Figure 3-15	Test Fixture Guarding	3-24
Figure 3-16	Power Line Ground Loops	3-25
Figure 3-17	Eliminating Ground Loops	3-25
Figure 3-18	Basic Leakage Test System	3-25
Figure 3-19	High-Speed Leakage Test System	3-26
Figure 3-20	Leakage Test System Equivalent Circuit	3-27
Figure 3-21	Automated Leakage Test System	3-27
Figure 3-22	Current Waveform Acquisition System	3-28
Figure 3-23	Self-Healing Oxide Breakdown Test System	3-29
Figure 3-24	Leakage Current Test Example	3-29

SECTION 4 — IEEE-488 Reference

Figure 4-1	SRQ Mask and Serial Poll Byte Format	4-15
Figure 4-2	Default Output Format (Suppress Value)	4-24
Figure 4-3	U0 Machine Status Word	4-25
Figure 4-4	U1 Error Status Word Format	4-26
Figure 4-5	U2 Word Format (Voltage Bias Value)	4-27
Figure 4-6	U3 Word Format (Total Gain)	4-27
Figure 4-7	U4 Word Format (Model Number and Firmware Revision)	4-28
Figure 4-8	Bus Connections	4-39

SECTION 5 — Performance Verification

Figure 5-1	Gain Accuracy Test Connections	5-3
Figure 5-2	Voltage Bias Check Connections	5-4
Figure 5-3	Current Suppression Check Connections	5-5

SECTION 6 — Theory of Operation

Figure 6-1	Overall Block Diagram	6-2
Figure 6-2	Analog Block Diagram	6-3
Figure 6-3	Signal Flow Diagram	6-3
Figure 6-4	Simplified Input Amplifier Schematic	6-5
Figure 6-5	Simplified Gain Model of Input Amplifier	6-5
Figure 6-6	Frequency Compensation	6-6
Figure 6-7	Zero Check Configuration	6-7
Figure 6-8	Simplified Schematic of Differential Amplifier	6-8
Figure 6-9	Simplified Filter Diagram	6-9
Figure 6-10	Filter Switching Diagram	6-10
Figure 6-11	Current Suppression	6-11
Figure 6-12	Simplified Schematic of Current Suppress Source	6-11
Figure 6-13	Voltage Bias Compensation	6-12
Figure 6-14	Basic Voltage Bias Source Configuration	6-13
Figure 6-15	Simplified Schematic of Voltage Bias Source	6-13
Figure 6-16	Simplified Schematic of Zero-crossing Detector	6-14
Figure 6-17	Simplified Schematic of Overload Detector	6-15
Figure 6-18	Block Diagram of Analog Control Circuits	6-16
Figure 6-19	Control Word	6-17
Figure 6-20	Digital Block Diagram	6-18
Figure 6-21	Memory Map	6-19
Figure 6-22	Analog Control Interface	6-20
Figure 6-23	Simplified Block Diagram of Serial Port	6-21
Figure 6-24	Display Board Block Diagram	6-22
Figure 6-25	Power Supply Block Diagram	6-22

SECTION 7 — Service Information

Figure 7-1	Mounting Test Equipment Recommended for Rise Time Adjustments	7-3
Figure 7-2	Adjustment Locations	7-4
Figure 7-3	Output Offset Adjustment Connections	7-5
Figure 7-4	Connections for Rise Time Adjustments	7-6
Figure 7-5	Waveform Adjustment	7-6
Figure 7-6	Model 428 Exploded View	7-8
Figure 7-7	Test Point Locations	7-10
Figure 7-8	Resistor Replacement	7-15
Figure 7-9	Bottom View of Mother Board	7-16

APPENDIX E — IEEE-488 Bus Overview

Figure E-1	IEEE-488 Bus Configuration	E-2
Figure E-2	IEEE-488 Handshake Sequence	E-3
Figure E-3	Command Codes	E-6

APPENDIX F — Typical Response Curves

Figure F-1	Typical Frequency Response with 10^3V/A Gain, Filter Off	F-1
Figure F-2	Typical Frequency Response with 10^4V/A Gain, Filter Off	F-1
Figure F-3	Typical Frequency Response with 10^5V/A Gain, Filter Off	F-2
Figure F-4	Typical Frequency Response with 10^6V/A Gain, Filter Off	F-2
Figure F-5	Typical Frequency Response with 10^7V/A Gain, Filter Off	F-2
Figure F-6	Typical Frequency Response with 10^8V/A Gain, Filter Off	F-2
Figure F-7	Typical Frequency Response with 10^9V/A Gain, Filter Off	F-3
Figure F-8	Typical Frequency Response with 10^3V/A Gain, 10 μsec Rise Time Filter	F-3
Figure F-9	Typical Frequency Response with 10^3V/A Gain, 30 μsec Rise Time Filter	F-3
Figure F-10	Typical Frequency Response with 10^3V/A Gain, 100 μsec Rise Time Filter	F-3
Figure F-11	Typical Frequency Response with 10^3V/A Gain, 300 μsec Rise Time Filter	F-4
Figure F-12	Typical Frequency Response with 10^3V/A Gain, 1msec Rise Time Filter	F-4
Figure F-13	Typical Frequency Response with 10^3V/A Gain, 3msec Rise Time Filter	F-4
Figure F-14	Typical Frequency Response with 10^3V/A Gain, 10msec Rise Time Filter	F-4
Figure F-15	Typical Frequency Response with 10^3V/A Gain, 30msec Rise Time Filter	F-5
Figure F-16	Typical Frequency Response with 10^6V/A Gain, 10 $\mu\text{,sec}$ Rise Time Filter	F-5
Figure F-17	Typical Frequency Response with 10^6V/A Gain, 100 μsec Rise Time Filter	F-5
Figure F-18	Typical Frequency Response with 10^8V/A Gain, 10 μsec Rise Time Filter	F-5
Figure F-19	Typical Frequency Response with 10^8V/A Gain, 100 μsec Rise Time Filter	F-6

List of Tables

SECTION 2 — Getting Started

Table 2-1	Abbreviated Command Summary	2-6
-----------	-----------------------------------	-----

SECTION 3 — Front Panel Operation

Table 3-1	Factory Default Conditions	3-2
Table 3-2	Display Error Messages	3-3
Table 3-3	Normal Display Messages	3-3
Table 3-4	Gain Settings	3-9
Table 3-5	Current Suppress Error Messages	3-10
Table 3-6	Current Suppress Ranges	3-10
Table 3-7	Auto Filter Rise Times	3-11
Table 3-8	Rise Time Display Values	3-12
Table 3-9	Frequency Response with Filter Off	3-13
Table 3-10	Filter Frequency Response	3-13
Table 3-11	Noise vs. Gain/Filter Selection	3-17
Table 3-12	Menu Selection	3-19
Table 3-13	Save/Recall Messages	3-20
Table 3-14	Factory Default Conditions	3-20
Table 3-15	Minimum Recommended Source Resistance Values	3-21

SECTION 4 — IEEE-488 Reference

Table 4-1	Device-dependent Command Summary	4-3
Table 4-2	Order of Command Execution	4-5
Table 4-3	General Bus Commands and Associated BASIC Statements	4-34
Table 4-4	Factory Default Conditions	4-36
Table 4-5	Front Panel Messages	4-37
Table 4-6	IEEE-488 Contact Assignments	4-39

SECTION 5 — Performance Verification

Table 5-1	Recommended Test Equipment	5-2
Table 5-2	Recommended Cables and Adapters	5-2
Table 5-3	Gain Accuracy Test Procedure	5-3
Table 5-4	Suppression Verification	5-6

SECTION 6 — Theory of Operation

Table 6-1	Filter Component Values	6-10
-----------	-------------------------------	------

SECTION 7 — Service Information

Table 7-1	Replacement Fuses	7-1
Table 7-2	Test Equipment Recommended for Offset Adjustment	7-2
Table 7-3	Test Equipment Recommended for Rise Time Adjustments	7-3
Table 7-4	Rise Time Adjustment Parameters	7-7
Table 7-5	Recommended Troubleshooting Equipment	7-9
Table 7-6	Power Supply Checks	7-10
Table 7-7	Digital Circuitry Checks	7-11
Table 7-8	Analog Circuitry Checks	7-12
Table 7-9	Comparator Checks	7-13
Table 7-10	Suppress Circuit Checks	7-13
Table 7-11	Voltage Bias Circuit Checks	7-14

APPENDIX A — Device-dependent Command Summary

Table A-1	Device-dependent Command Summary	A-1
-----------	--	-----

APPENDIX B — Interface Function Codes

Table B-1	Model 428 Interface Function Codes	B-1
-----------	--	-----

APPENDIX D — Controller Programs

Table D-1	BASIC Statements Necessary to Send Bus Commands	D-3
-----------	---	-----

APPENDIX E — IEEE-488 Bus Overview

Table E-1	IEEE-488 Bus Command Summary	E-4
Table E-2	Hexadecimal and Decimal Command Codes	E-7
Table E-3	Typical Addressed Command Sequence	E-7
Table E-4	Typical Device-dependent Command Sequence	E-7
Table E-5	IEEE Command Groups	E-8
Table G-1	Typical Bus Hold-off Times	G-1

SECTION 1

General Information

1.1 INTRODUCTION

This section contains general information about the Model 428 Current Amplifier, and it is arranged in the following manner:

1.2 Available Models

1.3 Features

1.4 Warranty Information

1.5 Manual Addenda

1.6 Safety Symbols and Terms

1.7 Specifications

1.8 Unpacking and Inspection

1.9 Repacking for Shipment

1.10 Optional Accessories

1.2 AVAILABLE MODELS

The Model 428 is available in two versions. The Model 428-PROG includes a built-in IEEE-488 interface, which allows the instrument to be programmed over the IEEE-488 bus. The Model 428-MAN is identical to the Model 428-PROG except that it does not include the IEEE-488 interface. This manual covers both versions of the instrument, and the designation Model 428 throughout the manual applies to both the Models 428-MAN and 428-PROG except for information concerning the IEEE-488 bus. Information that does not apply to the Model 428-MAN is indicated where appropriate.

1.3 FEATURES

The Model 428 Current Amplifier provides current-to-voltage conversion on eight ranges between 10^3V/A and 10^{10}V/A (10^{11}V/A with X10 gain enabled). Very fast response time allows the unit to be used in difficult applications such as in measuring very small, transient currents.

Key Model 428 features include:

- Enhanced current suppression: multiple current suppression ranges between $\pm 5\text{nA}$ and $\pm 5\text{mA}$ allow a wide range of steady-state currents to be suppressed. An automatic suppression feature simplifies the current suppression process.
- Programmable bias voltage: allows a fixed DC bias voltage from $\pm 2.5\text{mV}$ to $\pm 5\text{V}$ to be applied to the device connected to the input of the Model 428.
- Fast response time: $2\mu\text{sec}$ rise time (10-90%) at 10^3 and 10^4V/A gain (and 10^5V/A with x10 gain enabled) for fast current to voltage conversion.
- Programmable rise time filter: The rise time of the filter can be programmed for values between $10\mu\text{sec}$ and 300msec .
- Zero check: opens the input thus zeroing the output for easy checking of instrument offsets. Zero correct will automatically zero the input amplifier's voltage offset, to typically $<50\mu\text{V}$ of offset.
- Ease of use: simplified front panel design and versatile firmware for easy front panel setup and use.
- IEEE-488 interface (Model 428-PROG only): allows the unit to be programmed and controlled from a computer for automated instrument operation.
- Adjustable display intensity: normal/dim/off display modes for low-light or photosensitive applications.

1.4 WARRANTY INFORMATION

Warranty information is located on the inside front cover of this instruction manual. Should your Model 428 require warranty service, contact the Keithley representative or authorized repair facility in your area for further information. When returning the unit for repair, be sure to fill out and include the service form at the back of this manual in order to provide the repair facility with the necessary information.

1.5 MANUAL ADDENDA

Any improvements or changes concerning the instrument or manual will be explained in an addendum included with the unit. Be sure to note these changes and incorporate them into the manual before using or servicing the instrument.

1.6 SAFETY SYMBOLS AND TERMS

The following symbols and terms may be found on an instrument or used in this manual.

The  symbol on an instrument indicates that the user should refer to the operating instructions located in the instruction manual.

The **WARNING** heading used in this manual explains dangers that might result in personal injury or death. Always read the associated information very carefully before performing the indicated procedure.

The **CAUTION** heading used in this manual explains hazards that could damage the unit. Such damage may invalidate the warranty.

1.7 SPECIFICATIONS

Model 428 specifications are located at the front of this manual.

1.8 UNPACKING AND INSPECTION

1.8.1 Inspection for Damage

Upon receiving the Model 428, carefully unpack it from its shipping carton and inspect the instrument for any obvious signs of physical damage. Report any such damage to the shipping agent immediately. Save the original packing carton for possible future reshipment.

1.8.2 Shipment Contents

The following items are included with every Model 428 order:

- Model 428 Current Amplifier
- Line cord
- Model 428 Instruction Manual
- Quick Reference Guide
- Additional Accessories as ordered.

1.8.3 Instruction Manual

If an additional instruction manual is required, order the manual package, Keithley part number 428-901-00. The manual package includes an instruction manual and any applicable addenda.

1.9 REPACKING FOR SHIPMENT

Should it become necessary to return the Model 428 for repair, carefully pack the unit in its original packing carton or the equivalent, and include the following information:

- Advise as to the warranty status of the instrument.
- Write **ATTENTION REPAIR DEPARTMENT** on the shipping label.
- Fill out and include the service form located at the back of this manual.

1.10 OPTIONAL ACCESSORIES

Accessories that are recommended for use with the Model 428 are summarized below.

Model 4288-1 Single Fixed Rack Mounting Kit: The Model 4288-1 can be used to mount one Model 428 in a standard 19 in. rack. This kit includes one rack ear, a dress panel, and hardware necessary for mounting. The Model 4288-1 is 8.8cm (3.5 in.) in height.

Model 4288-2 Dual Fixed Rack Mounting Kit: The Model 4288-2 can be used to mount two Model 428s or similar instruments side by side in a standard 19 in. rack. The Model 4288-2 Kit includes two rack ears, two middle brackets, and hardware necessary for mounting.

Model 4801 Input Cable: The Model 4801 is a low-noise coaxial cable 1.2m (4 ft.) in length that is terminated with a male BNC connector on each end. The Model 4801 is recommended for both input and output connections to the Model 428.

Model 4802-10 Coaxial Cable: The Model 4802-10 is a low-noise coaxial cable 3m (10 ft.) long. The Model 4802-10 is terminated on one end with a male BNC connector, and it is unterminated on the other end.

Model 4803 Low-Noise Cable Kit: This kit includes 15m (15 ft.) of low-noise coaxial cable, 10 male BNC connectors, and five female BNC chassis-mount connectors.

Model 4804 Triax-to-BNC Adapter: The Model 4804 adapts 2-slot triax cables to the Model 428 INPUT jack.

Model 7007-1 and Model 7007-2 Shielded IEEE-488 Cables: The Model 7007 Shielded IEEE-488 cables include a shielded IEEE-488 connector (with metric screws) on each end. The Model 7007-1 is 1m (3.3 ft) long, and the Model 7007-2 is 2m (6.6 ft) in length. The Model 7007 cables are recommended for use with the Model 428-PROG and other instruments with IEEE-488 interfaces.

Model 7010 Shielded IEEE-488 to IEEE-488 Adapter: Provides additional clearance between the IEEE-488 cable and the rear panel of the Model 428-PROG.

Model 7051 Cables: BNC to BNC cables for the Model 428 output. Available versions: Model 7051-2 (0.6m, 2 ft.); Model 7051-5 (1.5m, 5 ft.); Model 7051-10 (3m, 10 ft.)

Model 7754-3 BNC to Alligator Cable: 0.9m (3 ft.) cable terminated with a male BNC connector on one end and two alligator clips on the other end.

SC-9: Low-noise coaxial cable without connectors (sold by the foot).

SECTION 2

Getting Started

2.1 INTRODUCTION

This section contains introductory information on using your Model 428 Current Amplifier. For detailed front panel and IEEE-488 bus operation, refer to Sections 3 and 4 respectively.

The information in this section is arranged as follows:

2.2 Front and Rear Panel Configuration: Briefly discusses the front and rear panel configuration of the Model 428.

2.3 Basic Front Panel Operation: Outlines a step-by-

step procedure for basic front panel operation.

2.4 Basic IEEE-488 Operation: Covers the basic steps necessary for using the Model 428-PROG over the IEEE-488 bus.

2.2 FRONT AND REAR PANEL CONFIGURATION

Figure 2-1 shows the front panel of the Model 428, and Figure 2-2 shows the rear panel of the instrument. Each of these figures includes important information that you should review before operating the instrument.

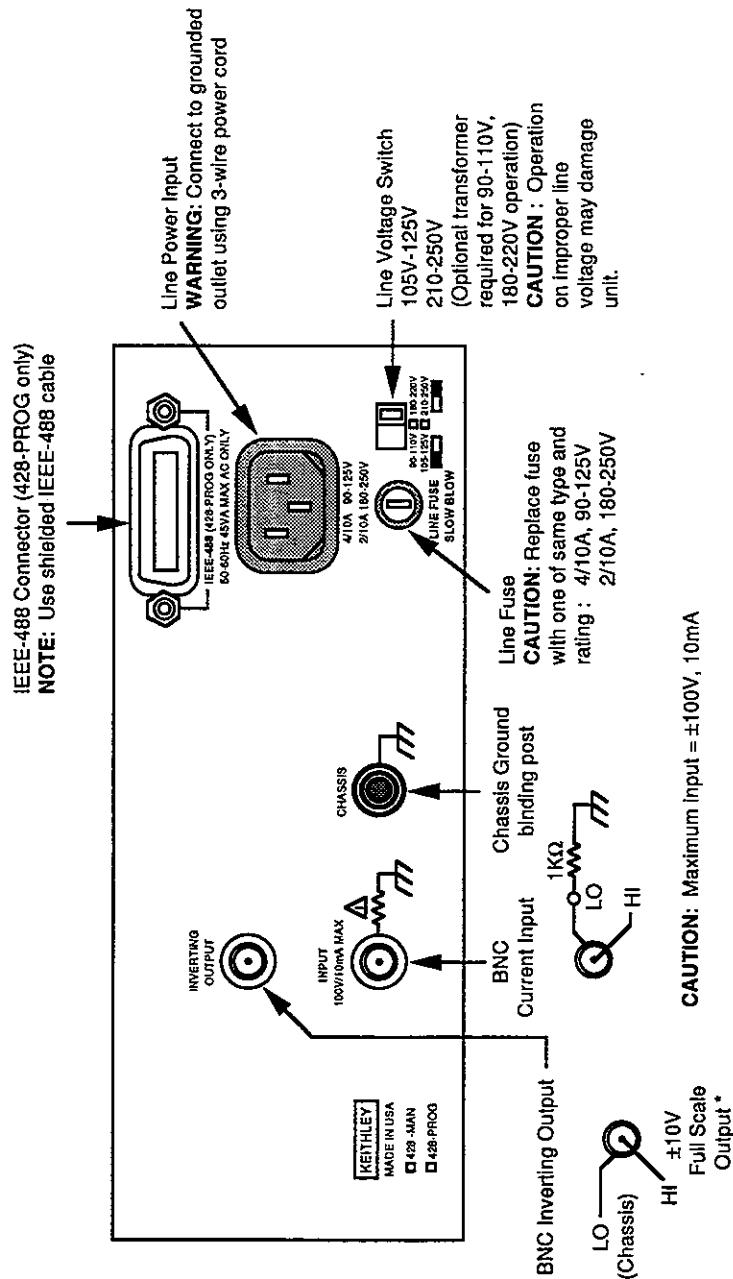

* with voltage bias off (see paragraph 3.4.5)

Figure 2-2. Model 428 Rear Panel

2.3 BASIC FRONT PANEL OPERATION

The steps below outline the basic procedure for using the Model 428 from the front panel.

1. Verify the rear panel line voltage switch is in the correct position for the power line voltage in your area. Connect the instrument to an appropriate power source using the supplied line cord, then turn on the power by pressing in on the front panel POWER switch.

WARNING

Use only a grounded AC outlet to avoid a possible shock hazard.

CAUTION

Operating the instrument on an incorrect line voltage may cause damage to the unit.

NOTE

If the front panel display should appear to be inoperative, try pressing the DISPLAY INTENSITY key once or twice to restore the display to normal intensity.

2. Press ZERO CHECK to enable zero check if it is not enabled.
3. Zero correct the instrument for optimum accuracy by pressing SHIFT, then CORRECT.
4. Connect the rear panel INPUT jack to the current source, and connect the INVERTING OUTPUT jack to the voltage-monitoring device (see Figure 2-3 for typical connections).
5. Press the SETUP GAIN key, then rotate the adjust knob (or press ◀ or ▶) to select the desired gain (10^3V/A – 10^{10}V/A with X10 gain off or 10^4V/A – 10^{11}V/A with X10 gain on).
6. If filtering is required, press FILTER RISE TIME, then use the adjust knob to select the desired rise

time (10%–90%, 10 μsec –300msec in a 1, 3, 10 sequence).

7. If the device connected to the input requires a DC bias voltage, press SETUP BIAS VOLTAGE, and use the knob and ◀ ▶ keys to set the bias to the required value ($\pm 5\text{V}$ maximum).
8. If the filter or voltage bias are to be used, press ENABLE FILTER or ENABLE VOLTAGE BIAS as required.
9. Disable zero check by pressing the ZERO CHECK button.
10. If you intend to suppress an offset current, perform the following steps:
 - A. Apply the current to be suppressed to the input.
 - B. If the "OVERLOAD" message is intermittently displayed, press SETUP GAIN, then reduce the gain until the overload condition is no longer present.
 - C. Press SHIFT AUTO to perform automatic current suppress.
 - D. If desired, you can then press SETUP CURRENT SUPPRESS to display the value of the suppressed current.
11. Apply the signal current to the input, then adjust the gain for the desired output value (if necessary, press SETUP GAIN to display gain before adjustment). If the instrument displays the "OVERLOAD" error message, reduce the gain as required until the overload condition no longer exists.

NOTE

Polarity convention is such that a current flowing out of INPUT HI will result in a positive output voltage, and a current flowing into INPUT HI will result in a negative output voltage.

12. When the measurement is complete, enable zero check to avoid a possible overload due to extraneous signals. In general, zero check should be left enabled while the instrument is turned on but not in use.

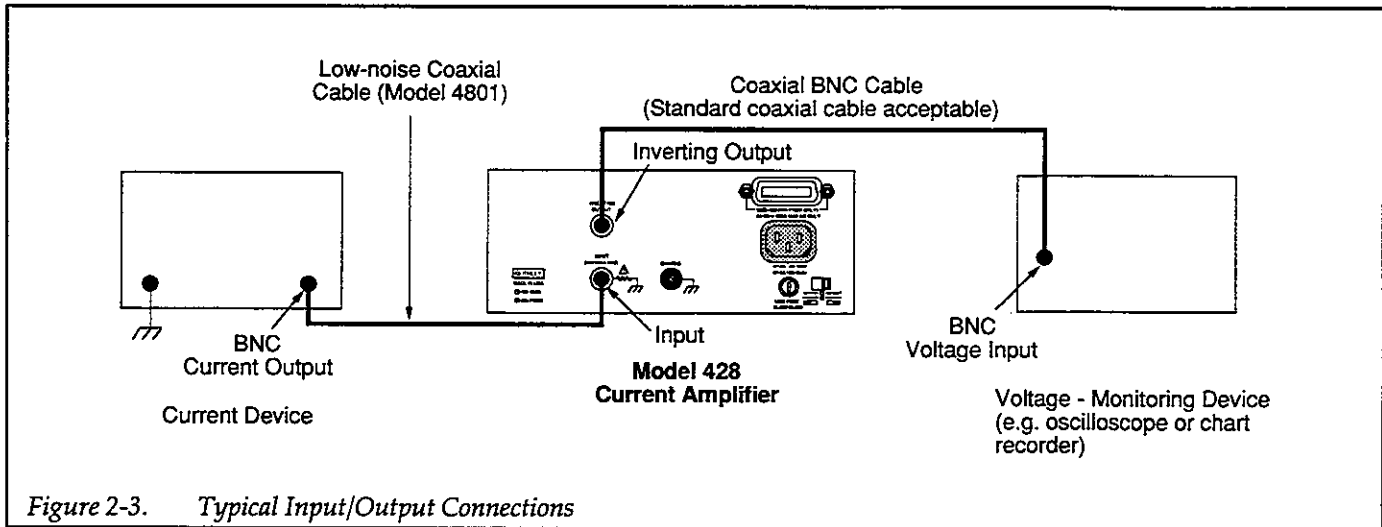

Figure 2-3. Typical Input/Output Connections

2.4 BASIC IEEE-488 OPERATION

The steps below outline the basic procedure to use the Model 428-PROG over the IEEE-488 bus. An abbreviated summary of commands necessary for basic operation is shown in Table 2-1. Simple controller programs that can be used to send these commands are listed in Appendix D of this manual.

1. With the power off, connect the Model 428 to the IEEE-488 bus of the controller. A shielded IEEE-488 cable such as the Keithley Model 7007 is recommended to minimize possible noise caused by electromagnetic interference.
2. Verify the rear panel line voltage switch is in the correct position for the power line voltage in your area. Connect the instrument to an appropriate power source using the supplied line cord, then turn on the power by pressing in on the front panel POWER switch.

WARNING

Use only a grounded AC outlet to avoid a possible shock hazard.

CAUTION

Operating the instrument on an incorrect line voltage may cause damage to the unit.

3. Verify that the programmed primary address displayed during the power up cycle is the same as the

one you intend to specify in your program. For example, with the default primary address of 22, the instrument will briefly display:

IEEE 22

4. If you desire to change the primary address of the instrument, you can easily do so as follows:
 - A. Press MENU twice to display the primary address:

IEEE 22

- B. Use the ◀ or ▶ key or rotate the adjust knob for the desired value (0-30).
 - C. Once the desired address is displayed, press MENU to save it.
 - D. Press SHIFT, then EXIT to return to normal operation.
5. Boot up your computer and load your test program (again, see Appendix D for programs that can be used to send commands).
 6. Make sure that zero check is enabled by sending C1X over the bus.
 7. Zero correct the instrument for optimum accuracy by sending the command C2X.
 8. Connect the rear panel INPUT jack to the current source, and connect the INVERTING OUTPUT jack to the voltage-monitoring device (see Figure 2-3 for typical connections).
 9. Program the desired gain by sending RnX, where n represents the gain option (see Table 2-1). For example, send R4X to program a gain of 10^4 .
 10. If filtering is required, program the desired filter rise time by sending TnX where n represents the filter rise time command option (Table 2-1). For example, send T2X to program a 100μsec filter rise time.

Table 2-1. Abbreviated Command Summary

Command	Description
B0*	Turn voltage bias off
B1	Turn voltage bias on
C0	Turn zero check off
C1*	Turn zero check on
C2	Perform automatic zero correct
N0*	Turn current suppress off
N1	Turn current suppress on
N2	Perform automatic current suppress
P0*	Filter off
P1	Filter on
R0	Select 10 ³ gain
R1	Select 10 ³ gain
R2	Select 10 ³ gain
R3*	Select 10 ³ gain
R4	Select 10 ⁴ gain
R5	Select 10 ⁵ gain
R6	Select 10 ⁶ gain
R7	Select 10 ⁷ gain
R8	Select 10 ⁸ gain
R9	Select 10 ⁹ gain
R10	Select 10 ¹⁰ gain
T0*	Select 10μsec filter rise time
T1	Select 30μsec filter rise time
T2	Select 100μsec filter rise time
T3	Select 300μsec filter rise time
T4	Select 1msec filter rise time
T5	Select 3msec filter rise time
T6	Select 10msec filter rise time
T7	Select 30msec filter rise time
T8	Select 100msec filter rise time
T9	Select 300msec filter rise time
Vn	Program voltage bias (-5 ≤ n ≤ +5, 2.5mV resolution)
W0*	X10 gain off
W1	X10 gain on
X	Execute other commands

*Indicates factory power-up defaults.

- If the device connected to the input requires a DC bias voltage, program the desired bias value by

sending the command VnX where n is a floating-point number in the range of -5 to +5 (2.5mV resolution). For example, to program a +2.2V bias voltage, send V2.2X.

- If the filter or voltage bias are to be used, send P1X to turn on the filter, and send B1X to enable the bias voltage.
- Disable zero check by sending C0X.
- To suppress an offset current, perform the following steps:
 - Apply the current to be suppressed to the input.
 - Check for an OVERLOAD by reading the U1 error word. If present, reduce the gain until the overload condition is no longer present by sending a new R command with the appropriate command option.
 - Send the command N2X to perform automatic current suppress.
- Apply the signal current to the input, then program the gain for the desired output value by sending the appropriate R command. If you note an overload condition, reduce the gain as required until the overload condition no longer exists.

NOTE

Polarity convention is such that a current flowing out of INPUT HI will result in a positive output voltage, and a current flowing into INPUT HI will result in a negative output voltage.

- When the measurement is complete, enable zero check by sending C1X to avoid a possible overload due to extraneous signals. In general, zero check should be left enabled while the instrument is turned on but not in use.

SECTION 3

Front Panel Operation

3.1 INTRODUCTION

This section contains detailed information on front panel operation of both the Model 428-MAN and the Model 428-PROG. Section 3 contains the following information:

3.2 Power-up Procedure: Gives a step-by-step procedure for line voltage selection and connecting the unit to line power, and also discusses power-up defaults.

3.3 Display Messages: Summarizes the error and informational messages that may appear while operating the Model 428.

3.4 Input/Output Connections: Details current input and voltage output connections to the instrument.

3.5 Data Programming: Discusses using the adjust knob and cursor keys to program numeric data.

3.6 Gain: Describes how to set the gain to the desired value as well as using X10 gain.

3.7 Current Suppress: Covers selecting current suppress range, setting the current suppress value, and automatic current suppression.

3.8 Filter: Details selecting the filter rise time and filter response, as well as auto filter selection.

3.9 Voltage Bias: Summarizes voltage bias level programming as well as enabling/disabling the voltage bias.

3.10 Zero Check and Zero Correct: Describes the operation of both zero check and zero correct.

3.11 Menu Selection: Covers operation of the menu, which will allow you to display the software revision, program the IEEE-488 primary address (428-PROG only), select auto filter on/off, save and recall instrument configuration, and perform the instrument self-test.

3.12 Display Intensity: Covers control of the normal/dim/off display intensity modes.

3.13 Measurement Considerations: Describes important measurement considerations that should be taken into account for best accuracy when using the Model 428.

3.14 Applications: Covers typical applications for the instrument.

3.2 POWER-UP PROCEDURE

The following paragraphs discuss line voltage selection, connecting the Model 428 to line power, as well as factory default conditions.

3.2.1 Line Voltage Selection

Before connecting the Model 428 to line power, check to see that the line voltage selection switch on the rear panel is in the correct position for the operating voltage in your area. The switch should be set to 105V-125V (90V-110V with optional power transformer), or 210V-250V (180V-220V with optional power transformer).

CAUTION

Operating the instrument on an incorrect line voltage may cause damage, possibly voiding the warranty.

3.2.2 Line Power Connections

Follow the procedure below to connect the Model 428 to line power and turn on the instrument.

1. First verify that the unit is set for the correct line voltage (see paragraph 3.2.1).
2. Before plugging in the power cord, make sure the front panel POWER switch is in the off (0) position.
3. Connect the female end of the supplied power cord to the AC receptacle on the rear panel. Connect the other end of the power cord to a grounded AC outlet.

WARNING

The power cord supplied with the Model 428 contains a separate ground wire designed to

be used with grounded outlets. When proper connections are made, instrument chassis is connected to power line ground through the ground wire in the power cord. Failure to use a grounded outlet may result in personal injury or death because of electric shock.

3.2.3 Power-up Sequence

1. Turn on instrument power by pressing in on and releasing the front panel power switch (position 1).
2. Upon power up, the instrument will perform a self-test on RAM, ROM, and E²ROM circuits. If an E²PROM checksum error is detected, the instrument will display a "NO DFLTS " (no defaults) error. To cancel one of these error messages, press a front panel key.
3. Assuming the unit passes its self-test, it will then display the software revision level, as in this example:

REV A01

4. A Model 428-PROG will then display the programmed IEEE-488 primary address:

IEEE 22

In this example, the factory default primary address of 22 is assumed.

A Model 428-MAN will display the following:

NO IEEE

5. Finally, the instrument will assume the normal operating mode with factory or user-defined setup, as discussed in the following paragraph.

3.2.4 Default Conditions

Default conditions are those conditions the instrument will assume when it is first turned on. Table 3-1 lists the

default conditions as programmed at the factory. You can change these default conditions by using the "DFLT SAVE" selection available with the MENU button, as described in paragraph 3.11.4 (except the IEEE-488 primary address, which is not affected by save/recall configuration).

Table 3-1. Factory Default Conditions

Mode	Default State
DISPLAY INTENSITY	Normal
CURRENT SUPPRESS	0.000mA, off
GAIN	10 ⁵ V/A
GAIN X10	Off
FILTER	Off
FILTER RISE TIME	10μsec
IEEE-488 Address*	22
VOLTAGE BIAS	0.000V, off
ZERO CHECK	On
AUTO FILTER	On

*428-PROG only

3.3 DISPLAY MESSAGES

Table 3-2 summarizes Model 428 front panel display error messages. Note that some of these messages apply only to the Model 428-PROG when used over the IEEE-488 bus (refer to Section 4).

Error messages fall into two categories: momentary or latching. A momentary message appears for approximately two seconds, after which the display returns to its previous state. A latching type message stays on the display until you press a front panel key (except if there is an overload condition).

Normal display messages are summarized in Table 3-3. Where applicable, the factory default settings are shown in the table.

Table 3-2. Display Error Messages

Message	Type	Description
CONFLICT*	Momentary	Conflict between suppression range and value
CORECT ERR	Latching	Input offset too large for zero correct (servicing required)
IDDC*	Momentary	Invalid Device-dependent Command
IDDCO*	Momentary	Invalid Device-dependent Command Option
NO DFLTS	Latching	EEPROM checksum error during power up or device clear
NO REMOTE*	Momentary	X received while not in remote
OUT OF RNG	Momentary	Input current too large for auto suppress
OVERLOAD	Latching	Input or output overload (message flashes while overload exists)
RAM ERROR	Latching	RAM error during self test (servicing required)
ROM ERROR	Latching	ROM error during self test (servicing required)
Z CHECK ON	Momentary	Auto suppress attempt with zero check on

*IEEE-488 messages for Model 428-PROG

Table 3-3. Normal Display Messages

Message*	Description
SHIFT	SHIFT key pressed
CORRECTING	Unit performing zero correct
SUPPRESSING	Unit performing auto suppress
1E03 V/A	GAIN display
10µsec	FILTER RISE TIME display
0.000mA	CURRENT SUPPRESS display
0.0000V	VOLTAGE BIAS DISPLAY
REV A01**	MENU software revision
IEEE 22***	MENU IEEE-488 address
AUTOFILT Y	MENU auto filter on
AUTOFILT N	MENU disable auto filter
DFLT OK	MENU no change to configuration
DFLT SAVE	MENU save configuration
DFLT RCL	MENU recall saved configuration
DFLT FCTRY	MENU restore factory defaults
SELFTEST N	MENU do not perform self test
SELFTEST Y	MENU perform self test
CHANGED	MENU item changed
NO CHANGE	MENU exit without change

*Numeric values depend on settings; factory defaults shown.

**Revision level may vary.

***428-PROG only

3.4 INPUT/OUTPUT CONNECTIONS

The following paragraphs discuss current input connections and voltage output connections to the Model 428.

3.4.1 Input Connections

As shown in Figure 3-1, the INPUT connector is a BNC jack used to apply current inputs to the Model 428. The center conductor is HI, while the outer ring is LO. Note that LO is connected to chassis through a flame proof $1k\Omega$ resistor to minimize the effects of ground loop currents when connected to other instruments. INPUT LO is intended to be operated at chassis potential; operation at voltages different than chassis will affect the dynamic range of the INVERTING OUTPUT.

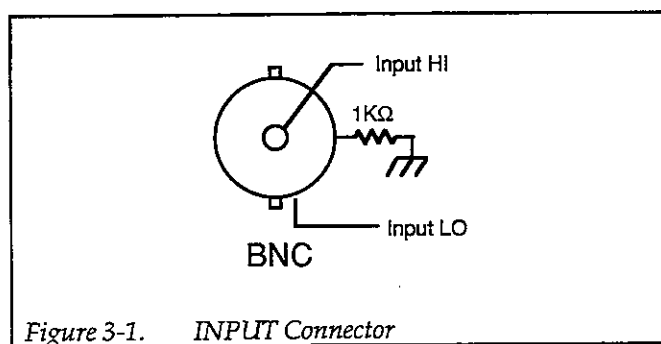

Figure 3-1. INPUT Connector

CAUTION

Maximum input is $\pm 100V$, $\pm 10mA$. Exceeding these levels may cause instrument damage.

CAUTION

Do not float INPUT LO above chassis ground potential. The instrument may not operate properly, and the internal $1k\Omega$ fusible resistor may be destroyed.

Figure 3-2 shows example input connections to the Model 428. Typical devices connected to INPUT include electron microscopes and particle accelerators.

NOTE

Use only low-noise coaxial cable such as the Model 4801 for input connections in order to minimize noise. The use of standard BNC coaxial cables for input connections is not recommended because of the higher triboelectric noise that may be generated, interfering with sensitive measurements.

3.4.2 Output Connections

Figure 3-3 shows the configuration of the INVERTING OUTPUT connector of the Model 428. Again, the center conductor is HI, and the outer ring is LO. Note that the outer ring of INVERTING OUTPUT is connected to chassis ground.

Figure 3-4 shows typical output connections. Typical instruments connected to the output include oscilloscopes, chart recorders, voltage-to-frequency converters, and A/D converters. Note that standard coaxial cable can be used for the output because the requirements are less critical than for the input.

3.4.3 Cable Capacitance

Excessive capacitance caused by long input or output cables may cause overshoot, ringing, or even oscillations on the output waveform. To minimize these undesirable effects, keep input and output cables as short as possible. In cases where reducing cable length is not practical, install a resistor in series with input HI or output HI as the case may be. The optimum resistance value depends on the gain and capacitance (typically $1k\Omega$ - $10k\Omega$). Note that adding resistance may affect frequency response.

3.4.4 Current-to-Voltage Conversion Polarity

Conversion polarity is such that a current flowing out of INPUT HI will result in a positive output voltage, while a current flowing into INPUT HI will result in a negative output voltage. Full scale output is $\pm 10V$ with $0V$ bias voltage.

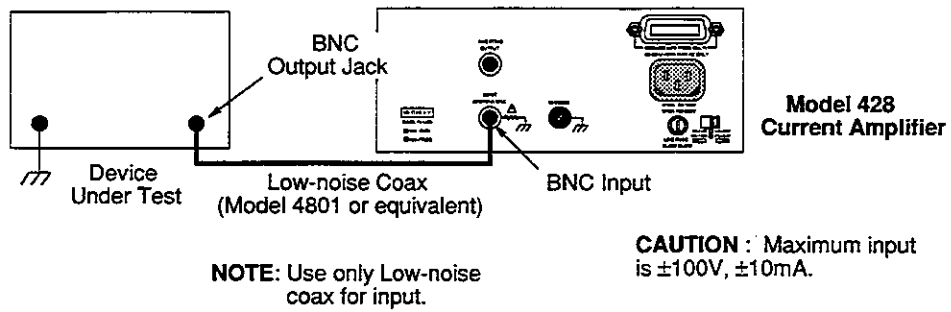

A. Connections

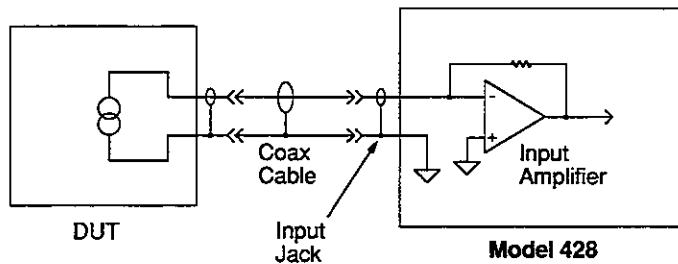

B. Equivalent Circuit

Figure 3-2. Typical Input Connections

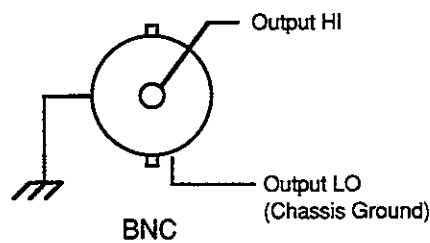
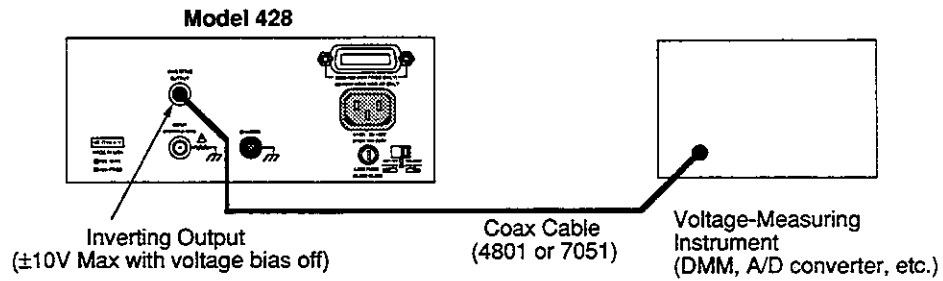
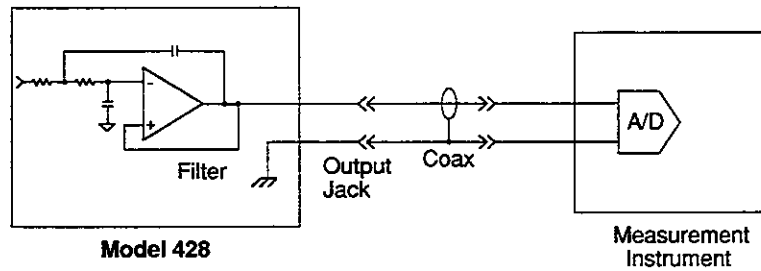

Figure 3-3. INVERTING OUTPUT Connector



A. Connections



B. Equivalent Circuit

Figure 3-4. Typical Output Connections

3.4.5 Maximum Input Current without Overload

The maximum input current that can be applied without causing an overload depends on the selected overall gain, whether or not the voltage bias source is enabled. The following paragraphs discuss maximum input current limitations both with voltage bias disabled and voltage bias enabled. Figure 3-5 shows these relationships graphically.

Voltage Bias Off With or Without X10 Gain Enabled

When voltage bias is off, the maximum output voltage of the INVERTING OUTPUT is $\pm 10V$. Thus the maximum input current without overloading depends on the displayed gain, as follows.

$$|I_{IN(max)}| = \frac{10}{A} \quad \text{Eq. 1}$$

Where: $|I_{IN(max)}|$ = absolute value of input current (amperes)

A = displayed gain (V/A), which includes X10 gain (if enabled)

For example, assume that the displayed gain is $10^6 V/A$. The absolute value of the maximum input current is:

$$|I_{IN(max)}| = \frac{10}{10^6}$$

$$|I_{IN(max)}| = 10\mu A$$

Note that a negative input current results in a positive output voltage, and a positive input current results in a negative output voltage as outlined in paragraph 3.4.4.

Voltage Bias On, X10 Gain Disabled

When voltage bias is enabled, the maximum input current that can be applied without overload with a given gain is reduced **only when the input current and bias voltage are of opposite polarity** (a positive current flows into INPUT HI, and a negative current flows out of INPUT HI). When the input current and bias voltage are of opposite polarity, the maximum input current is:

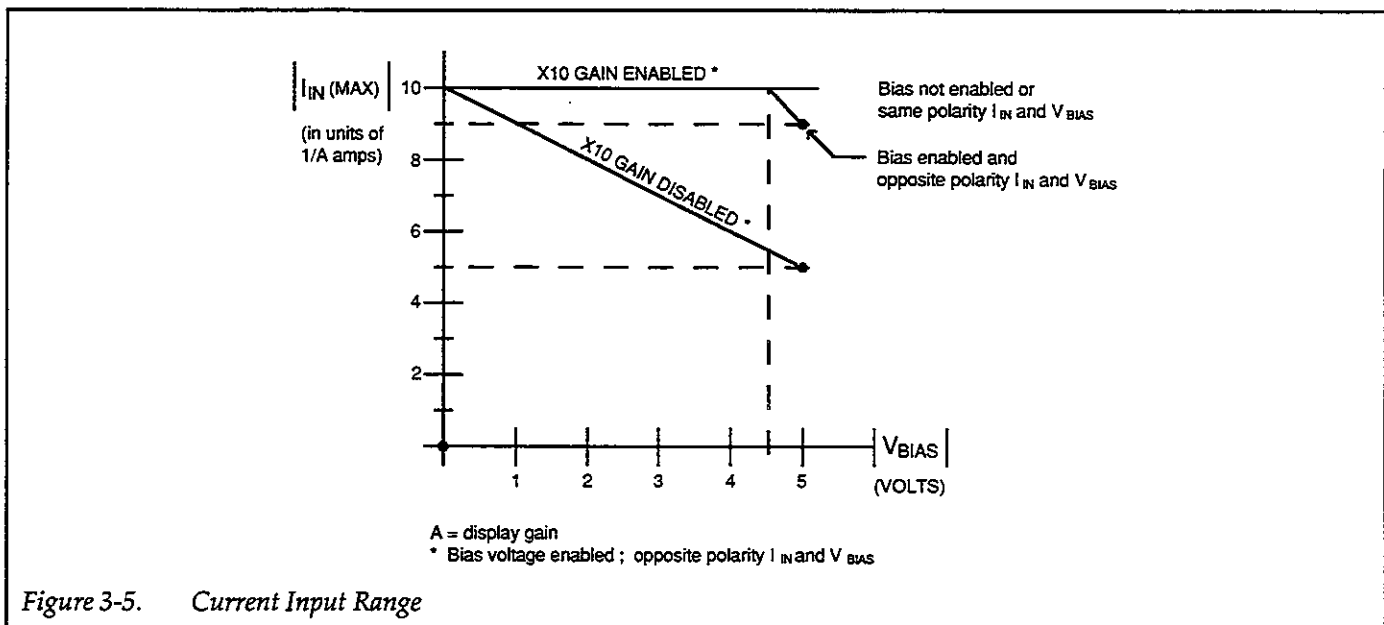

Figure 3-5. Current Input Range

$$|I_{IN(max)}| = \frac{10 - |V_{BIAS}|}{A} \quad \text{Eq. 2}$$

Where: $|I_{IN(max)}|$ = absolute value of maximum input current (amperes)
 $|V_{BIAS}|$ = absolute value of bias voltage (volts)
 A = gain (V/A)

Note that input range is not symmetrical when voltage bias is on, and that noise level must be subtracted from input range (a consideration at higher gain levels).

Note that this limitation does not apply when both the input current and voltage bias have the same polarity; Equation 1 applies when both input current and voltage bias have the same polarity.

As an example, assume a voltage bias value of +5V and a gain of 10^3 V/A. The maximum negative current (current flowing out of INPUT) is:

$$I_{IN(max)} = \frac{10 - 5}{10^3}$$

$$I_{IN(max)} = -5\text{mA}$$

The maximum positive current (current flowing into INPUT) in this situation would be +10mA as defined by Equation 1.

Voltage Bias On, X10 Gain Enabled

When both voltage bias and X10 gain are enabled (and when I_{IN} and V_{BIAS} are of opposite polarity), the maximum input current is defined as follows:

$$|I_{IN(max)}| = \frac{10|V_{BIAS}|}{0.55A} \quad \text{for } |V_{BIAS}| > 4.5V \quad \text{Eq. 3}$$

or, Eq. 4

$$|I_{IN(max)}| = \frac{10}{A} \quad \text{for } |V_{BIAS}| < 4.5V$$

Where: $|I_{IN(max)}|$ = absolute value of input current (amperes)
 $|V_{BIAS}|$ = absolute value of bias voltage (volts)
 A = displayed gain (V/A), including X10 gain

When I_{IN} and V_{BIAS} have the same polarity, the above relationships do not apply (see Eq. 1).

For example, with a gain of 10^4 V/A and a bias voltage of 5V, the maximum input current is:

$$|I_{IN(max)}| = \frac{10 - 4}{0.55A}$$

$$|I_{IN(max)}| = 0.9\text{mA}$$

3.5 DATA ENTRY

The paragraphs below discuss operation of the adjust knob and the cursor keys.

NOTE

Any changes made in the various operating modes will be reflected immediately on the display but they will not affect the instrument hardware until zero check is disabled (paragraph 3.10).

3.5.1 Adjust Knob and Cursor Key Operation

The adjust knob and cursor keys (◀▶) are used for a variety of front panel control adjustments (note that the cursor keys will auto repeat if held down for more than a second). For many adjustments, you can use either the knob or the cursor keys to make the adjustment; these controls include:

- GAIN
- FILTER RISE TIME
- MENU IEEE-488 Address (428-PROG only)
- MENU auto filter
- MENU save/recall
- MENU self-test

In addition, the adjust knob and cursor keys perform the following functions:

SETUP CURRENT SUPPRESS: Use the cursor keys to select cursor position and range; use the knob to adjust the value.

SETUP VOLTAGE BIAS: Use the cursor keys to select cursor position; use the knob to adjust the value.

3.5.2 Data Entry Examples

Example 1: Select filter rise time.

1. Press **SETUP FILTER RISE TIME**, and note that the instrument displays the selected filter rise time (10µsec-300msec).
2. Press **▶** or rotate the knob clockwise to increase the rise time.
3. Press **◀** or rotate the knob counterclockwise to decrease rise time.

Example 2: Select gain

1. Press **SETUP GAIN** and note that the instrument displays the selected gain (10³-10¹⁰V/A, X10 gain off).
2. Press **▶** or rotate the knob clockwise to increase gain.
3. Press **◀** or rotate the knob counterclockwise to decrease gain.

Example 3: Program voltage bias.

1. Press **SETUP VOLTAGE BIAS**.
2. Use **◀** or **▶** to move to the desired digit to change (flashing digit indicates cursor position).
3. Rotate the knob to set the value of the selected digit.
4. Repeat steps 2 and 3 for all digits to be changed.

3.6 GAIN

The gain setting determines the overall ratio of the current-to-voltage conversion process. The following paragraphs discuss setting the gain and using X10 gain.

3.6.1 Setting the Gain

As summarized in Table 3-4, the available gain values range from 10³V/A to 10¹⁰V/A (10¹¹V/A with X10 gain enabled). Table 3-4 also shows display messages as well as full scale current inputs for ±10V outputs for each gain value.

NOTE

The bias voltage value affects the maximum output. See paragraph 3.4.5.

To set the gain, first press **SETUP GAIN**, then use the knob or cursor keys to set the gain for the desired output voltage. If the instrument displays the "OVERLOAD" message, reduce the gain as appropriate.

Table 3-4. Gain Settings

Gain	Displayed Value	Full Scale Input Current*
10 ³ ***	1E03 V/A	±10mA
10 ⁴	1E04 V/A	±1mA
10 ⁵	1E05 V/A	±100µA
10 ⁶	1E06 V/A	±10µA
10 ⁷	1E07 V/A	±1µA
10 ⁸	1E08 V/A	±100nA
10 ⁹	1E09 V/A	±10nA
10 ¹⁰	1E10 V/A	±1nA
10 ¹¹ ***	1E11 V/A	±100pA

*Current for ±10V output @ 0V bias voltage (see paragraph 3.4.5)

**Not available with X10 gain enabled.

***Available only with X10 gain enabled.

3.6.2 X10 Gain

The **GAIN X10** key provides a convenient way to expand the overall gain by an order of magnitude. X10 Gain allows you to maintain your present rise time but gain a factor of ten in amplification. For example, with X10 disabled, 10⁸V/A gain has a rise time of 40µsec. If you change to 10⁹ gain, rise time becomes 100µsec. Enabling X10 gain at 10⁸V/A gain results in a rise time of 40µsec.

Another advantage of using X10 gain is that you can maintain full input range with bias voltages up to ±4.5V. Refer to paragraph 3.4.5. To expand the gain by X10, simply press **GAIN X10**; the associated LED will turn on to indicate that X10 gain is in effect, and the display will change to reflect the overall gain. To disable X10 gain, press **GAIN X10** a second time. Note that the range of gain values is between 10⁴V/A and 10¹¹V/A with X10 gain enabled.

NOTE

The overall gain accuracy of the instrument as well as the temperature coefficient is affected

by using X10 gain. Overall gain accuracy and temperature coefficient can be obtained by adding the X10 gain specifications to the gain setting specifications. For example, the 10^3 V/A accuracy is $\pm 0.45\%$, and X10 gain adds $\pm 0.2\%$ for a total of $\pm 0.65\%$. However, noise, rise time, and input resistance are not affected by X10 gain.

3.7 CURRENT SUPPRESSION

Current suppression allows you to null a residual or offset current present at the input of the instrument, either manually, or automatically. The following paragraphs discuss programming suppress values, enabling/disabling suppression, and auto suppression.

3.7.1 Suppression Error Messages

Error messages associated with current suppression are summarized in Table 3-5.

Table 3-5. Current Suppress Error Messages

Message	Description
CONFLICT*	Conflict between suppression range and value.
OUT OF RNG	Input current to large to suppress
Z CHECK ON	Zero check on when attempting auto suppress

*This message occurs on the display only with certain IEEE-488 bus commands.

3.7.2 Programming Current Suppression

Follow the steps below to program the current suppression value.

1. Press SETUP CURRENT SUPPRESS to display the suppression value.
2. Set the suppression range to the desired range with the ◀ or ▶ key using Table 3-6 as a guide. Use ▶ to decrease the range, and use ◀ to increase the range. Since these keys also set cursor position, you must

first advance the cursor to the extreme right or left before the range will change.

3. Once the desired range is displayed, use the appropriate cursor key to select the digit to be changed.
4. Rotate the knob to choose the desired value for the selected digit.
5. Repeat steps 3 and 4 for all digits to be changed.

Table 3-6. Current Suppression Ranges

Range	Display Format*
$\pm 5\text{nA}$	0.000nA
$\pm 50\text{nA}$	00.00nA
$\pm 500\text{nA}$	000.0nA
$\pm 5\mu\text{A}$	0.000 μA
$\pm 50\mu\text{A}$	00.00 μA
$\pm 500\mu\text{A}$	000.0 μA
$\pm 5\text{mA}$	0.000mA

*Display with zero suppress value.

3.7.3 Enabling Current Suppression

To apply the programmed current suppression value, press ENABLE CURRENT SUPPRESS. The indicator will turn on to show that suppression is enabled, and the output voltage will reflect the difference between the applied current and the programmed suppression value. For example, assume that you previously suppressed a current of 1mA, and the applied current is 4mA. The output voltage with a gain of 10^3V/A is: $(4\text{mA}-1\text{mA}) \times 10^3\text{V/A} = 3\text{V}$.

Press ENABLE CURRENT SUPPRESS a second time to disable suppression.

3.7.4 Manual Suppression Procedure

The following procedure assumes that suppression is to be adjusted for a 0V output.

1. Connect the current source to the input, and connect an appropriate voltage measuring instrument to the output of the Model 428.
2. Turn on the power, and select the gain, filter rise time, and voltage bias as desired.
3. Apply the current to be suppressed, then disable zero check if enabled; reduce the gain as necessary if the instrument displays the "OVERLOAD" message.

4. Press SETUP CURRENT SUPPRESS then ENABLE CURRENT SUPPRESS.
5. Using the knob and cursor keys, adjust the suppress value for an output voltage of 0V.
6. Apply the signal current, and adjust the gain as necessary for a convenient output voltage.

3.7.5 Auto-Suppression

Auto-suppression can be used to automatically null a given offset. The basic procedure for using auto-suppression is summarized in the steps below.

1. Connect the current source to the input.
2. Turn on the power, and select the gain, filter rise time, and voltage bias value as required for the expected signal.
3. Apply the current to be suppressed, then disable zero check if enabled. If the instrument displays the "OVERLOAD" message, reduce the gain as necessary.
4. Press SHIFT, then AUTO to perform auto suppression. When the process has been completed, suppression will be left enabled.
5. To view the suppression value, press SETUP CURRENT SUPPRESS.

3.8 FILTER

The Model 428 incorporates a programmable filter with a -12dB/octave (-40dB/decade) roll-off to ensure optimum wide-band performance with minimal noise. The paragraphs below discuss rise time programming, enabling the filter, and give typical filter response curves.

3.8.1 Auto-Filter

The Model 428 includes an auto-filter feature that allows you to select whether or not some filtering is always applied to higher gain values even when the filter is not enabled. In most cases, the Model 428 should be operated with auto-filter on to ensure minimum noise at higher gain settings. Some applications, such as when the Model 428 is being used as part of a control loop, may require that the Model 428 be operated with auto-filter off to ensure minimum delay in control loop applications. Typical of such control loop applications are:

- Controlling synchrotron ring current, with the Model 428 connected to the radiation sensors.

- Controlling probe position on a tunneling electron microscope, with the Model 428 sensing tunneling current.

When 10^8 - 10^{10} V/A gain values are selected, filter default rise times are automatically placed into effect when auto-filter is enabled and when the filter is turned off. As summarized in Table 3-7, these rise time values are minimum suggested values intended to minimize noise at higher gain settings.

Table 3-7. Auto-Filter Rise Times

Gain (V/A)*	Filter Rise Time (µsec).**	Output Rise Time (µsec).
10^3	Off	2
10^4	Off	2
10^5	Off	5
10^6	Off	10
10^7	Off	10
10^8	10	40
10^9	30	100
10^{10}	100	250

*With X10 gain off
**Filter off, auto-filter on

Auto-filter on/off can be selected with the MENU button as follows:

1. Press MENU three times (twice on a Model 428-MAN) until the following is displayed:

AUTOFILTY

2. Use the knob or the ◀▶ keys to select auto on or auto off. For auto-filter on, select:

AUTOFILTY

3. For auto-filter off choose:

AUTOFILTN

4. Once the desired state is displayed, you must press MENU to save the change and return to normal operation.

3.8.2 Filter Rise Time

The filter rise time setting determines the roll-off point of the filter as well as the pulse response to transient inputs.

Table 3-8 summarizes filter rise times as well as the display message for each setting. As shown in Figure 3-6, the rise time is defined as the period required for the output voltage to go from 10% to 90% of final value in response to an ideal step input.

Table 3-8. Rise Time Display Values

Rise Time Display
10μSEC
30μSEC
100μSEC
300μSEC
1mSEC
3mSEC
10mSEC
30mSEC
100mSEC
300mSEC

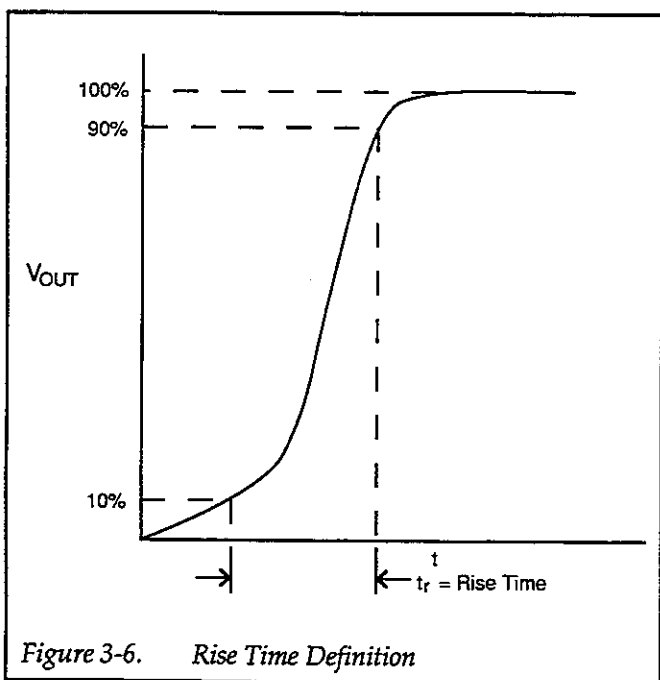

Rise time can be set as follows:

1. Press SETUP FILTER RISE TIME to display the present rise time setting.
2. Press **▶** or rotate the knob clockwise to increase rise time.
3. Press **◀** or rotate the knob counterclockwise to decrease rise time.

3.8.3 Enabling the Filter

To enable the filter, simply press the ENABLE FILTER key. The FILTER LED will turn on to indicate that the filter is enabled. If you have selected 10^9 - 10^{10} V/A gain and have chosen a rise time lower than the recommended defaults for auto-filter (see Table 3-7), the FILTER LED will flash to indicate that you have chosen a rise time setting faster than the input amplifier rise time. The Model 428 output rise time can be faster than the values shown in Table 3-7. The filter setup affects only the rise time of the -12 dB/octave filter and is the value displayed when you set rise time. Only when the output filter rise time is less than or equal to the values in Table 3-7, will the displayed rise time equal the output rise time.

To turn the filter off, press ENABLE FILTER a second time. Keep in mind, however, that filtering will still be applied with auto-filter on and 10^8 - 10^{10} V/A gain values selected even when with FILTER off (see Table 3-7).

3.8.4 Frequency Response

Instrument and filter response values are given in the time domain for the convenience of those working with transients. However, instrument bandwidth in the frequency domain is also important. As discussed in the following paragraphs, the overall frequency response of the instrument is determined by the gain setting, whether or not the filter is enabled, and the selected rise time (when the filter is enabled).

Frequency Response with Filter Off

The input amplifier alone has a frequency response that approximates that of a single-pole low-pass filter. As a result, the response rolls off at a rate of -6 dB per octave with a -3 dB point that depends on the selected gain, as summarized in Table 3-9.

Filter Response

When the filter is enabled, additional filtering is applied to the signal. The -3 dB response point of this filter is determined by the selected rise time, as summarized in Table 3-10. Response rolls off at -12 dB per octave (-40 dB per decade). These roll-off values are in addition to the -6 dB per octave (-20 dB per decade) response of the input amplifier itself. Consequently, the total roll-off is -18 dB per octave (-60 dB per decade) above the -3 dB point when the filter is enabled.

Table 3-9. Frequency Response with Filter Off

Gain (V/A)	Rise Time (μsec)	-3dB Response (kHz)
10 ³	2	175
10 ⁴	2	175
10 ⁵	5	70
10 ⁶	10	35
10 ⁷	10	35
10 ⁸	40	7
10 ⁹	100	3.5
10 ¹⁰	250	1.4

Note: rise time and response values are typical. Times are with auto-filter off.

Table 3-10. Filter Frequency Response

Filter Rise Time	-3dB Response
10μsec	35kHz
30μsec	12kHz
100μsec	3.5kHz
300μsec	1.2kHz
1msec	350Hz
3msec	120Hz
10msec	35Hz
30msec	12Hz
100msec	3.5Hz
300msec	0.12Hz

Note: Response for filter only; does not include I-V converter amplifier response. All values are typical.

Overall Frequency Response

The overall frequency response of the Model 428 includes the effects of both the -6db per octave roll-off of the input amplifier along with the -12dB per octave roll-off when the filter is enabled. The overall response of the instrument at any given frequency is simply the sum in dB of the attenuations of these two roll-offs. For example, at a frequency well above the higher -3dB point, the response rolls off at -18dB per octave (-60dB per decade).

Example response curves are shown in Figure 3-7. The dotted line shows response with filter off, and the solid line shown combined filter and input amplifier response.

Additional example overall response curves are located in Appendix F.

Filter Phase and Delay Characteristics

The filter used in the Model 428 is specifically designed for minimal phase shift and constant delay throughout the passband. Figure 3-8 through Figure 3-12 show typical response curves for amplitude, phase, and delay for various filter rise times.

NOTE

Curves shown are for the filter only and do not include input amplifier characteristics.

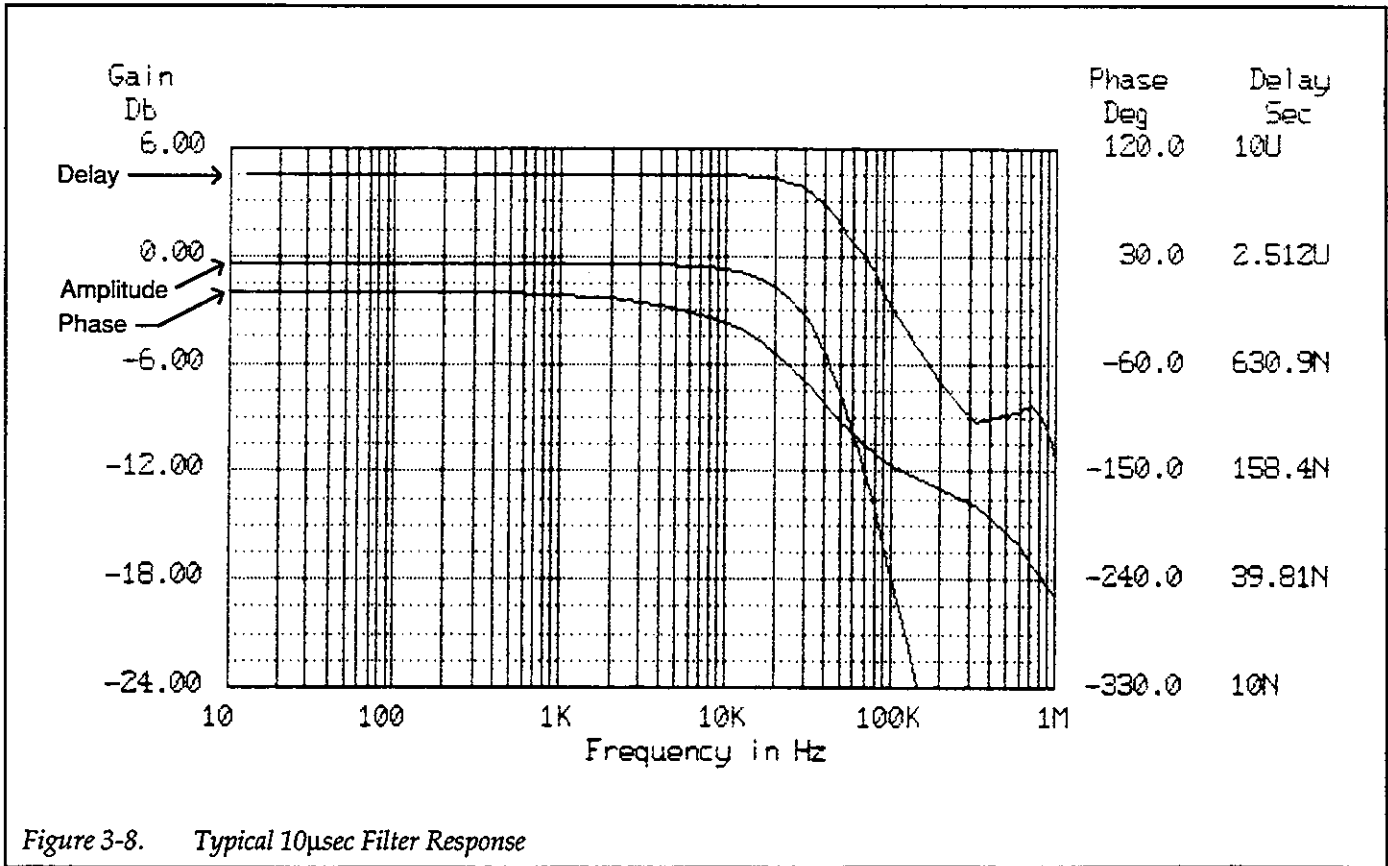
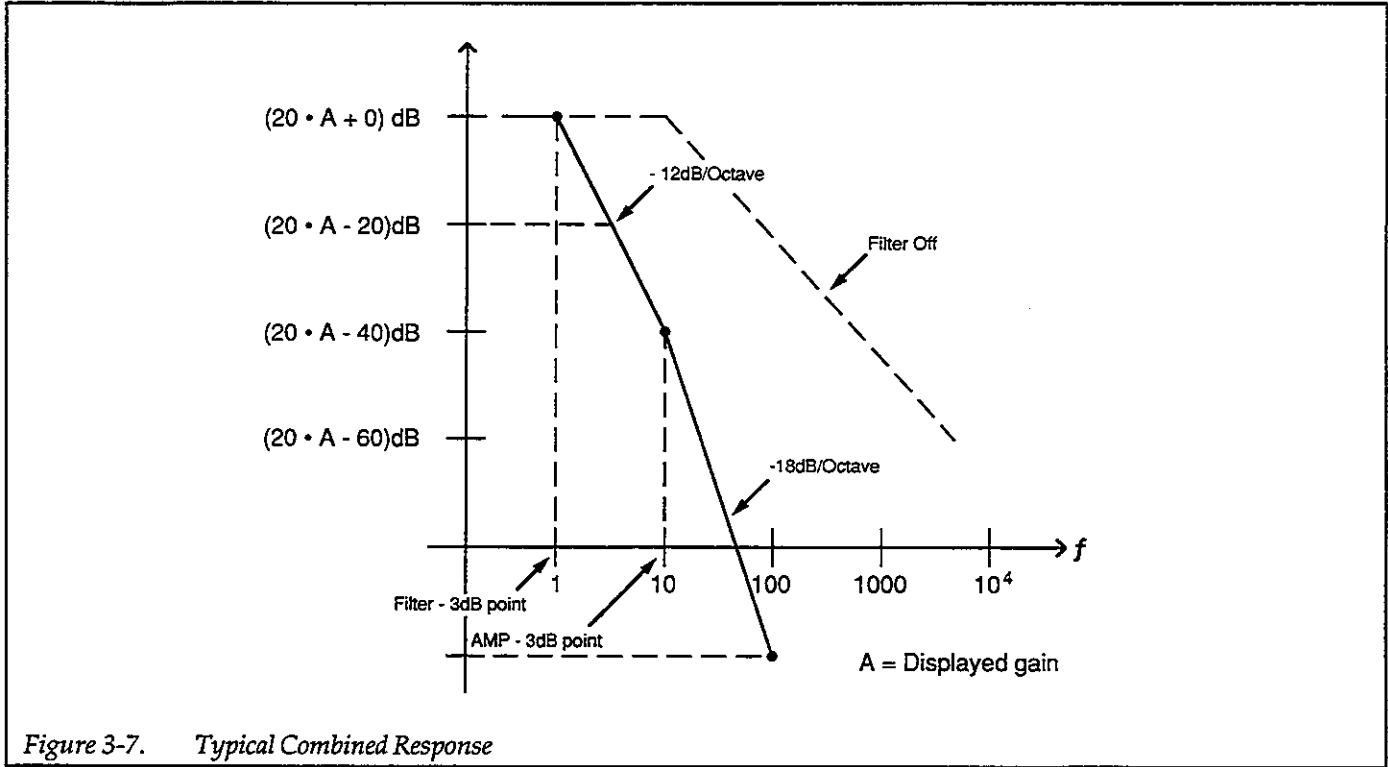

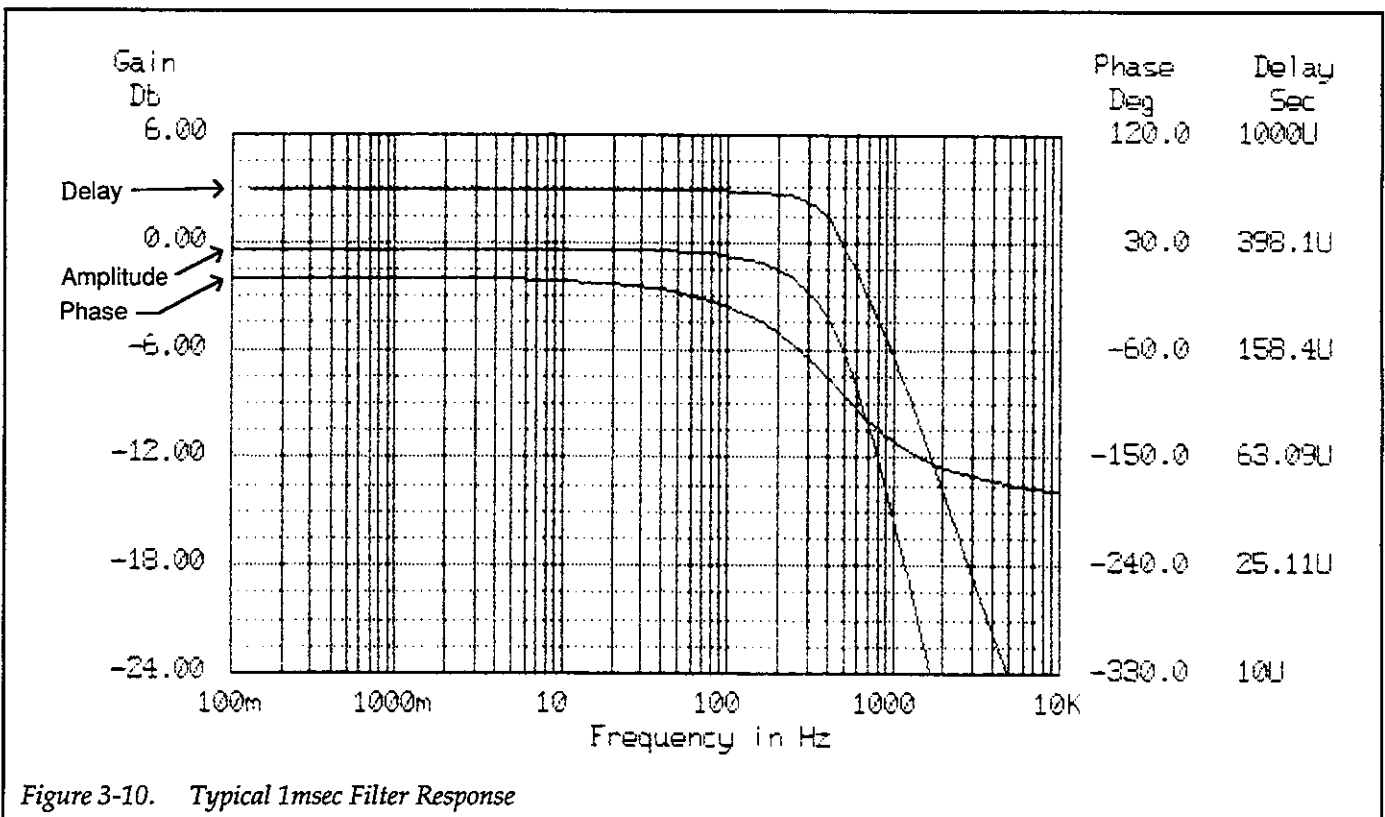
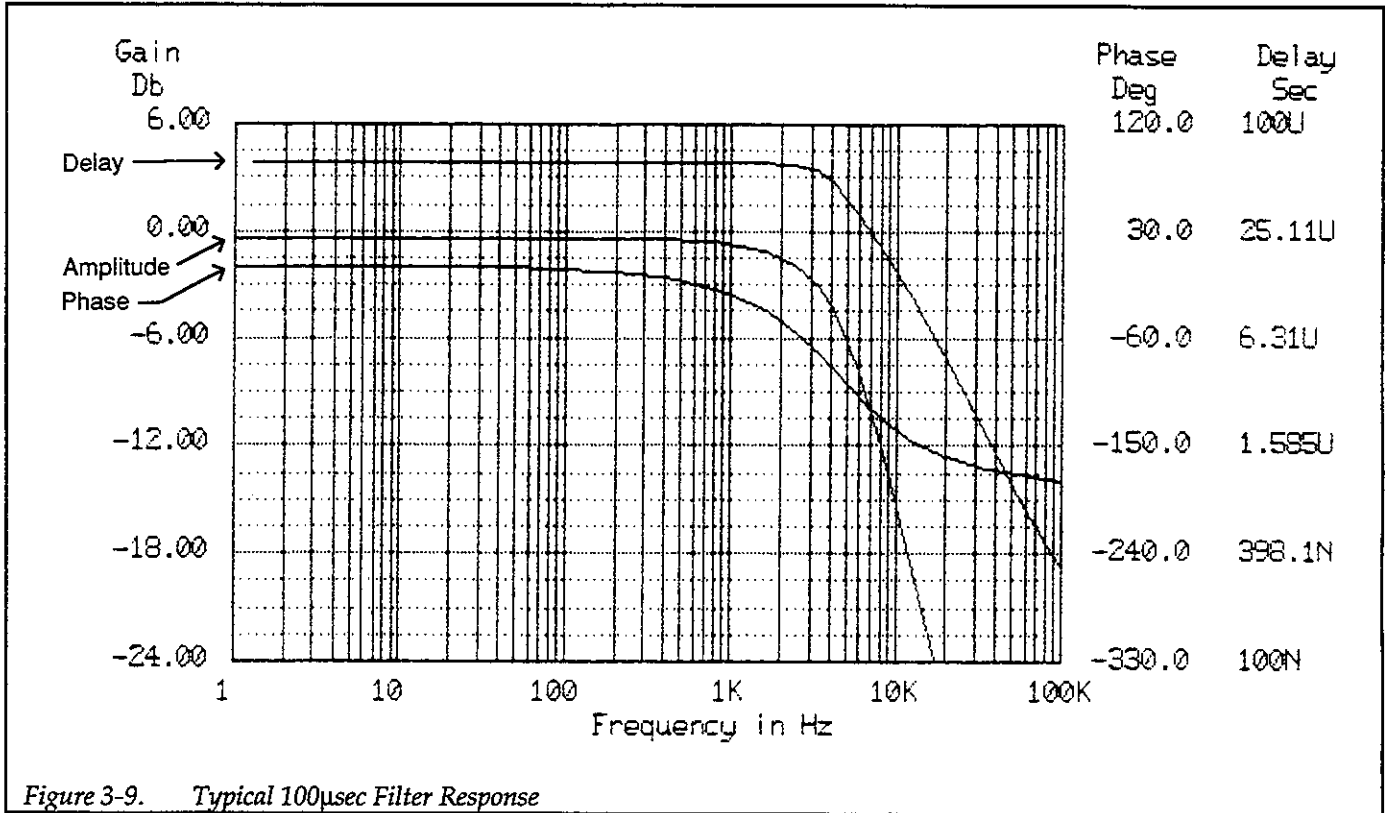

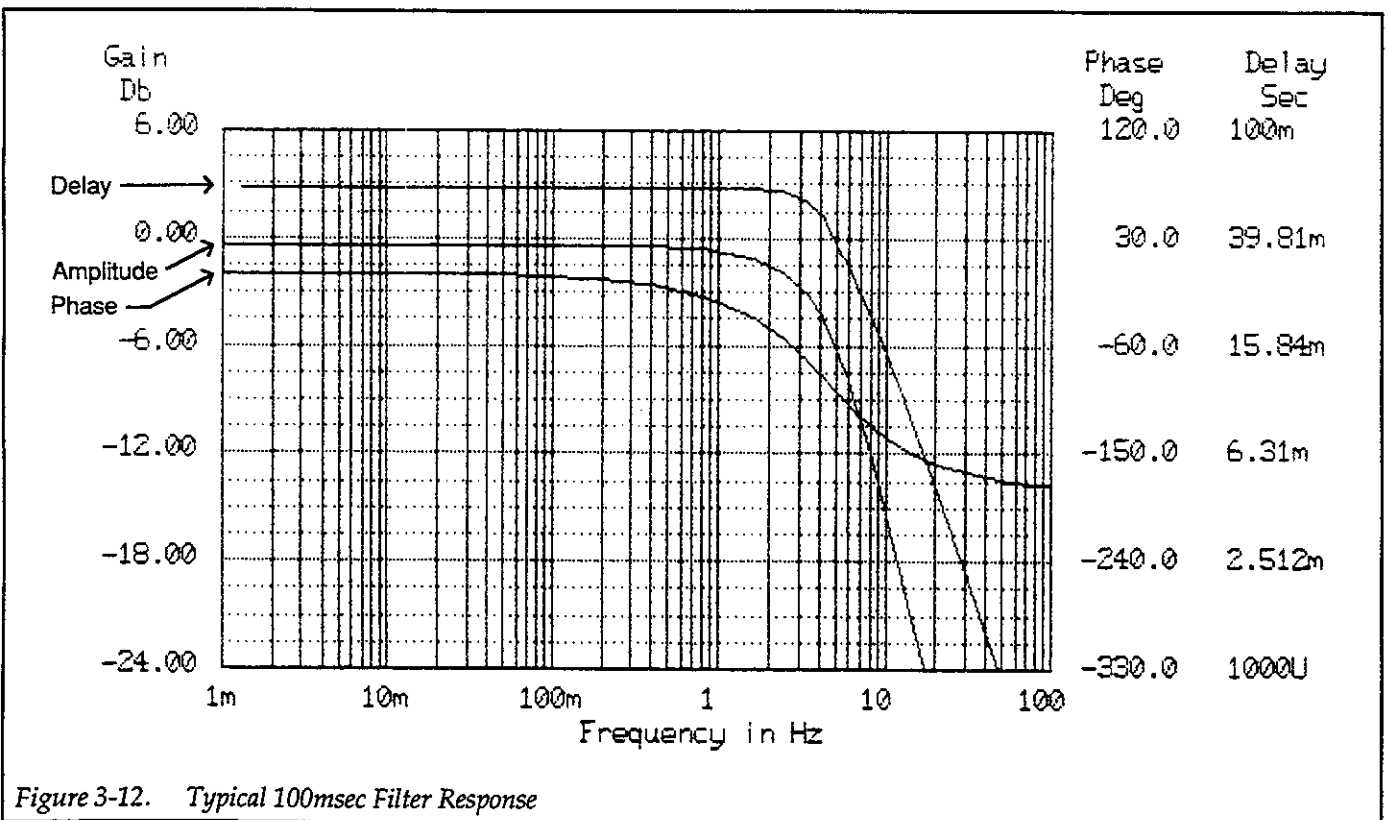
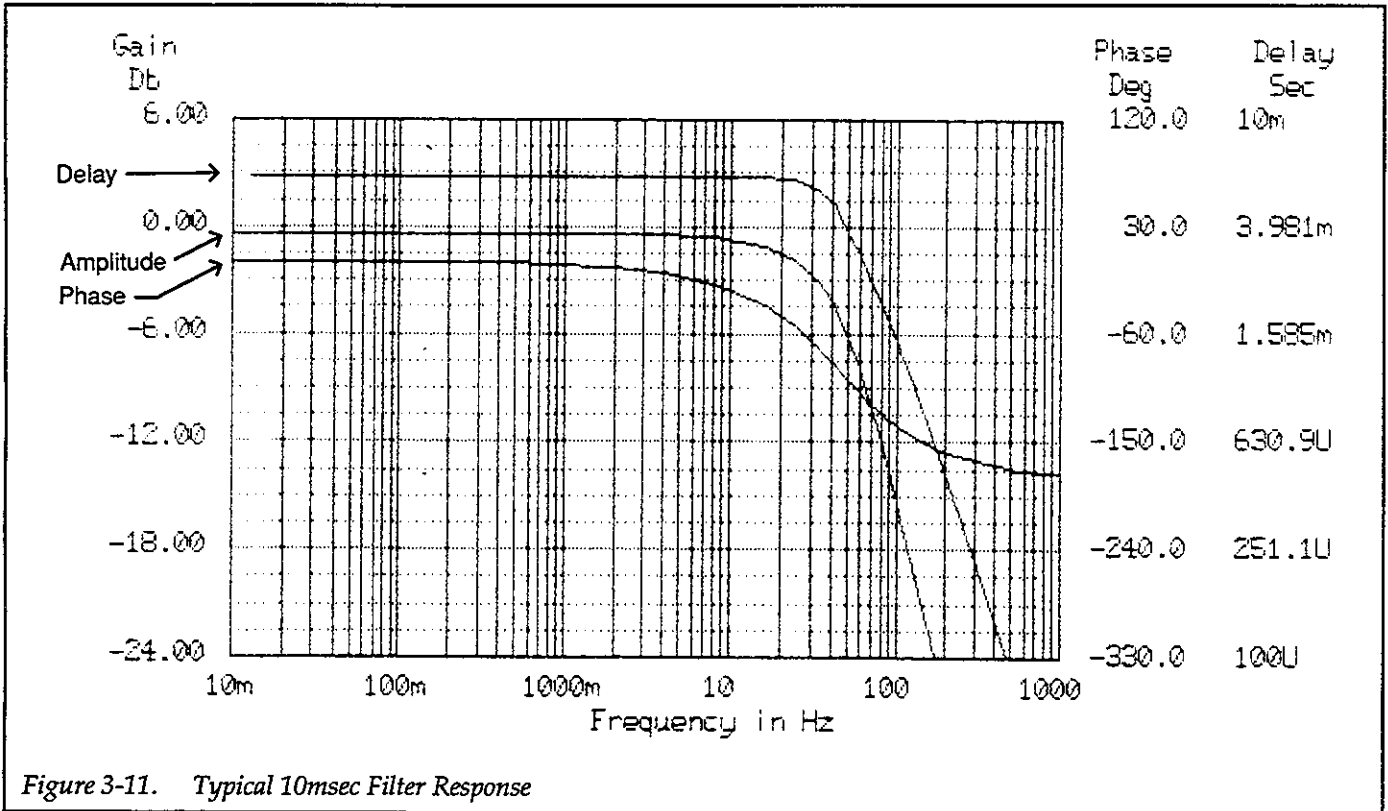

3.8.5 Optimum Gain/Filter Selection

The purpose of the filter is, of course, to reduce noise. The amount of noise present is determined not only by unwanted outside signals induced in the test system, but it can also be influenced by such factors as source resistance and source capacitance (see paragraph 3.13).

It may be beneficial or even necessary to trade slow rise time for lower noise by choosing an optimum filter rise time and enabling the filter.

One of the better ways to select optimum filtering is to monitor the output of the Model 428 with an oscilloscope. If you see noise on the output waveform, enable the filter and adjust the filter rise time until the noise is reduced to an acceptable level. Note, however, that excessive filter-

ing may cause undesirable distortion to signal waveforms, particularly those with fast rise times or wide bandwidths. Often the best filter rise time setting becomes a compromise between best noise performance and minimum signal distortion.

Table 3-11 shows how gain and rise time interact. In the area to the left of the bold line, filter rise time settings affect both noise and rise time. In the area to the right of the bold line, filter rise time settings affect only noise. The shaded areas indicate the optimum gain/filter setting for each gain value. When auto-filter is on and filter is off, these are the rise time settings automatically placed into effect. When filter is turned on, auto-filter is disabled. Table 3-11 shows typical RMS noise current as a function of gain and rise time.

Table 3-11. Noise vs. Gain/Filter Selection

Gain (V/A)	Filter Rise Time Setting										Noise + Rise Time	Noise
	300msec	100msec	30msec	10msec	3msec	1msec	300µsec	100µsec	30µsec	10µsec	Off	
10 ⁶	—	—	—	—	—	—	80pA	16pA	16pA	16pA	500pA	
10 ⁷	—	—	—	—	—	1.2pA	8pA	2.5pA	7pA	35pA	200pA	
10 ⁸	—	—	—	—	—	0.5pA	1pA	2pA	9pA	20pA	30pA	
10 ⁹	—	—	—	0.1pA	0.5pA	0.9pA	1.2pA	2.3pA	4.8pA	10pA	10pA	
10 ¹⁰	—	—	—	0.05pA	0.25pA	0.5pA	0.9pA	1.4pA	1.6pA	2pA	2pA	

Note: All values are typical with up to 100pF shunt capacitance on input. Noise increases as shunt capacitance increases. Shaded area indicates optimum noise/rise setting for each gain. 10³-10⁵ gain rise time optimum value is filter off.

3.9 VOLTAGE BIAS

The internal voltage bias source can be used to apply a $\pm 5\text{V}$ DC bias voltage across a device connected across the INPUT connector. Various aspects of using the voltage bias source are covered below.

3.9.1 Voltage Bias Setup

Set up the voltage bias value as follows:

1. Press SETUP VOLTAGE BIAS to display the voltage bias value. For example, with 0V programmed, the display will show:

0.0000V

2. Press ◀ or ▶ to select the digit to adjust.
3. Rotate the knob to set the selected digit to the desired value.
4. Repeat steps 2 and 3 until all digits are set to the desired value. Note that the maximum voltage bias is $\pm 5\text{V}$ and the resolution is 2.5mV.

3.9.2 Enabling Voltage Bias

To enable voltage bias and apply the voltage across the input device, press ENABLE VOLTAGE BIAS. To turn off the bias, press ENABLE VOLTAGE BIAS a second time.

NOTES:

1. Voltage bias polarity is such that a positive programmed voltage will result in a positive voltage at INPUT HI with respect to INPUT LO. Conversely, a negative programmed voltage will result in a negative voltage at INPUT HI with respect to INPUT LO. See Figure 3-13.
2. Zero check must be turned off before the programmed voltage will appear across the INPUT connector terminals. With zero check on, the output voltage will be set to 0V regardless of the programmed voltage even when voltage bias is enabled.
3. The voltage bias value affects the maximum input range available. See paragraph 3.4.5.

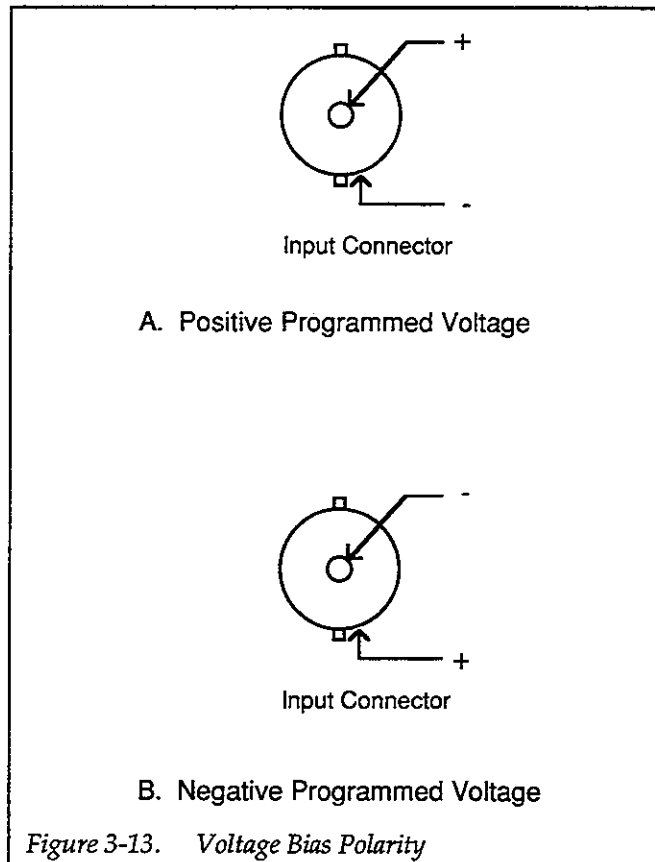

3.10 ZERO CHECK AND ZERO CORRECT

3.10.1 Zero Check

When zero check is enabled, the user's HI input is disconnected from the amplifier and connected to LO through 18 Ω . This allows the output to assume a value that represents zero input current. Normally, zero check should be left enabled when the instrument is turned on but not in use to avoid possible input amplifier overloads by extraneous signals.

NOTE

Zero check must be disabled to obtain a normal signal output voltage, and to apply the programmed voltage bias to the device connected to the input. Note that displayed operating modes can be changed immediately, but the hardware will not reflect those changes until zero check is disabled.

To disable or enable zero check, simply press the ZERO CHECK key. The ZERO CHECK indicator will be on

when zero check is enabled, and it will be off when zero check is disabled.

3.10.2 Zero Correct

Zero correct provides a convenient method to zero instrument offsets and maintain maximum instrument accuracy. The procedure below details the zero-correction process. For maximum accuracy, the instrument should be zero corrected after each hour of operation or if the ambient temperature varies widely. Note that it is not necessary to enable zero check to zero correct the instrument, as the instrument will automatically do so as part of the correction process.

1. Press SHIFT, then CORRECT to zero correct the instrument. The unit will enable zero check (if not already enabled) and display the following message while performing the corrections process:

CORRECTING

Note that the ZERO CHECK led will also flash during the correction process.

2. If the correction process was successful, the unit will return to normal operation with zero check in its original state (off if previously off, on if previously turned on).
3. If, however, the offset is too large to correct, the unit will display the correction error message instead:

CORECT ERR

NOTES

1. A correction error indicates that a problem may exist with the instrument. Refer to Sections 6 and 7 for servicing information.
2. Zero correction constants are not automatically stored in the E²ROM. To save the correction, use the save configuration menu option.

3.11 MENU SELECTION

The paragraphs below discuss using the MENU key to access the software revision, primary address (Model 428-PROG only), auto-filter on/off, save/recall instrument configuration, and the self-test. MENU display messages are summarized in Table 3-12.

Table 3-12. Menu Selection

Display	Description
REV A01	Software revision level*
IEEE 22	IEEE-488 primary address**
AUTOFILT Y	Autofilter on (Y) or off (N)
DFLT OK	Save/recall configuration
SELFTST N	Perform self test
CHANGED	Indicates menu selection was changed
NO CHANGE	Exit menu with no changes

*Displayed value depends on software revision level

**Model 428-PROG only; factory default shown

To select each item in the menu, press the MENU key. You can then make appropriate selections for most menu items as outlined below. If you change a menu item, the instrument will briefly display the following:

CHANGED

To exit the menu at any point, press SHIFT, then EXIT, or press one of the SETUP keys. If no changes were made while in the menu, the instrument will briefly display the following:

NO CHANGE

3.11.1 Software Revision

To display the software revision level of your unit, press MENU once from the normal display. The unit will display the software revision level, as in the following example:

REV A01

Note that the displayed revision level may be different from that indicated above. You should record the revision level of your unit should it ever require service in the future. Press SHIFT, then EXIT to return to normal display after viewing the software revision level.

3.11.2 IEEE-488 Primary Address

The IEEE-488 primary address selection display appears in the menu for a Model 428-PROG only. When using the instrument over the IEEE-488 bus, the programmed primary address must be the same as the address specified in the controller's programming language.

You can display or program the primary address as follows:

1. From the normal display, press MENU twice.
2. The Model 428 will display the present primary address:

IEEE 22

In this example, the factory default value of 22 is shown.

3. To return to normal display at this point without changing the address, press SHIFT, then EXIT.
4. To change the address, use the knob or cursor keys to select the desired value within the allowed range (0 to 30).
5. Once the desired address is displayed, press MENU to save it, then press SHIFT, then EXIT to return to normal display.

3.11.3 Auto-Filter

The auto-filter selection in the menu allows you to turn the automatic filter on or off. When automatic filter is turned on, default rise time settings are automatically placed into effect for 10^8 - 10^{10} gain values when the filter is disabled. Detailed information on the automatic filter is located in paragraph 3.8.1.

To turn the auto-filter on or off, follow the steps below:

1. From the normal display, press the MENU key three times (twice for the Model 428-PROG).
2. The instrument will then display the current auto filter state; for auto-filter on, the display will show:

AUTOFILT Y

For auto filter off, the display will appear as follows:

AUTOFILT N

3. Use the knob or cursor keys to select the desired auto filter state, then press MENU to save it. Press SHIFT, then EXIT to return to normal display.

3.11.4 Save/Recall Configuration

The save/recall configuration menu selection allows you to save the present operating state of the instrument as default, recall the saved configuration, or restore factory defaults. Table 3-13 summarizes available options for this menu selection, and Table 3-14 outlines factory default conditions. This table also indicates those operating states that can be saved.

Table 3-13. Save/Recall Messages

Message	Description
DFLT OK	No action, maintain present state
DFLT SAVE	Save present configuration as power-up and recall defaults
DFLT RCL	Recall saved configuration
DFLT FCTRY	Recall factory default configuration

Table 3-14. Factory Default Conditions

Mode	Default State
DISPLAY INTENSITY	Normal
CURRENT SUPPRESS	0.000mA, off
GAIN	10^5 V/A
GAIN X10	Off
FILTER	Off
FILTER RISE TIME	10 μ sec
VOLTAGE BIAS	0.000V, off
ZERO CHECK	On
AUTOFILTER	On

NOTE

Save configuration stores the present zero correct constants.

Select save/recall configuration as follows:

1. Press MENU four times (three times for the Model 428-MAN) until the following is displayed:

DFLT OK

2. Use the knob or cursor keys to select the desired operation (see Table 3-13).

3. Press MENU to complete the selection process, then press SHIFT, then EXIT to return to normal display if you saved a setup.

3.11.5 Self-test

The self-test option allows you to test the front panel LEDs as well as the RAM and ROM ICs within the instrument. To use self-test, proceed as follows:

1. Press MENU five times (four times for the Model 428-MAN) to display the following:

SELFTEST N

2. To run the self-test, use the knob or cursor keys to display the following:

SELFTEST Y

3. Press MENU to begin the self-test. The unit will then test the display segments and digits in sequence and then return to normal display if the RAM and ROM ICs pass the tests.
4. If a RAM or ROM error occurs during the self-test, the unit will display one of the following messages:

RAM ERROR

or,

ROM ERROR

In this instance, you must press a front panel key to return to normal display.

NOTE

A RAM or ROM error indicates a probable problem with the instrument. Run the self-test several times to see if the failure occurs consistently. If so, refer to Section 7, Service Information.

3.12 DISPLAY INTENSITY

The DISPLAY INTENSITY key allows you to set the display intensity to one of three settings. The normal intensity is intended for normal ambient room light, the dim

setting is for low-light situations, and the off position is intended for photosensitive applications.

To set the display intensity, simply press the DISPLAY INTENSITY key on the front panel. The intensity will cycle from normal to dim to off and then back to normal with each successive key press. Note that the POWER indicator remains on at a very dim level when the off setting is selected. The display intensity setting can be saved as the power up default under the menu option.

NOTE

If you save OFF intensity, the unit may appear to be inoperative on power-up.

3.13 MEASUREMENT CONSIDERATIONS

There are a number of considerations that should be taken into account when using the Model 428. The following paragraphs discuss the most important of these considerations and methods to minimize undesirable effects.

3.13.1 Source Resistance

As shown in Table 3-15, a minimum source resistance value is recommended for each gain setting. The reasons for this limitation involve the amplification factor of inherent amplifier noise, as we will now discuss.

Table 3-15. Minimum Recommended Source Resistance Values

Gain V/A	Minimum Source Resistance
10^3	1k Ω
10^4	10k Ω
10^5	100k Ω
10^6	1M Ω
10^7	10M Ω
10^8	100M Ω
10^9	1G Ω
10^{10}	10G Ω

Figure 3-14 shows a simplified model of the input amplifier. The source resistance is R_s , and the gain of the amplifier is set by the feedback resistor, R_{FB} . The source capaci-

tance is C_s , and the feedback capacitance is C_{FB} . The noise voltage of the amplifier is represented by E_{NOISE} , while the offset voltage is E_{OS} .

At lower frequencies, the impedances of C_s and C_{FB} are high enough that they can be ignored for all practical purposes. Thus, the noise voltage, E_{NOISE} , which excites the noninverting terminal of the op amp, is amplified as follows:

$$\text{Output } E_{NOISE} = \text{Input } E_{NOISE} \times (1 + R_{FB}/R_s)$$

This relationship shows that the output noise voltage increases as the value of the source resistance decreases. As long as the source resistance is substantially larger than the feedback resistance, the output noise voltage will equal the input noise voltage. However, when $R_s = R_{FB}$, the output noise voltage will be twice the input noise voltage. Thus, using a source resistance value equal to the feedback resistance (the values in the table also indicate the feedback resistance value for a given gain), will result in only a slight increase in noise. Reducing the value of R_s even further will result in a corresponding increase in in-

put amplifier noise. For example, if $R_{FB} = (1/9)R_s$, the noise will be increased by a factor of 10.

The same general considerations also apply to the offset voltage, E_{OS} , which will be amplified by the factor given in the above equation. Although the zero correct feature is intended to null any offset, the correction may not be as accurate when excessively low source resistance values are used.

3.13.2 Source Capacitance

The source capacitance should be kept as low as possible in order to minimize detrimental effects on the measurement. Not only will the rise time increase with increased source capacitance, but noise may increase as well.

At higher frequencies, the noise gain of the circuit in Figure 3-14 must be modified to include the effects of C_s and C_{FB} as follows:

$$\text{Output } E_N = \text{Input } E_N \times (1 + Z_{FB}/Z_s)$$

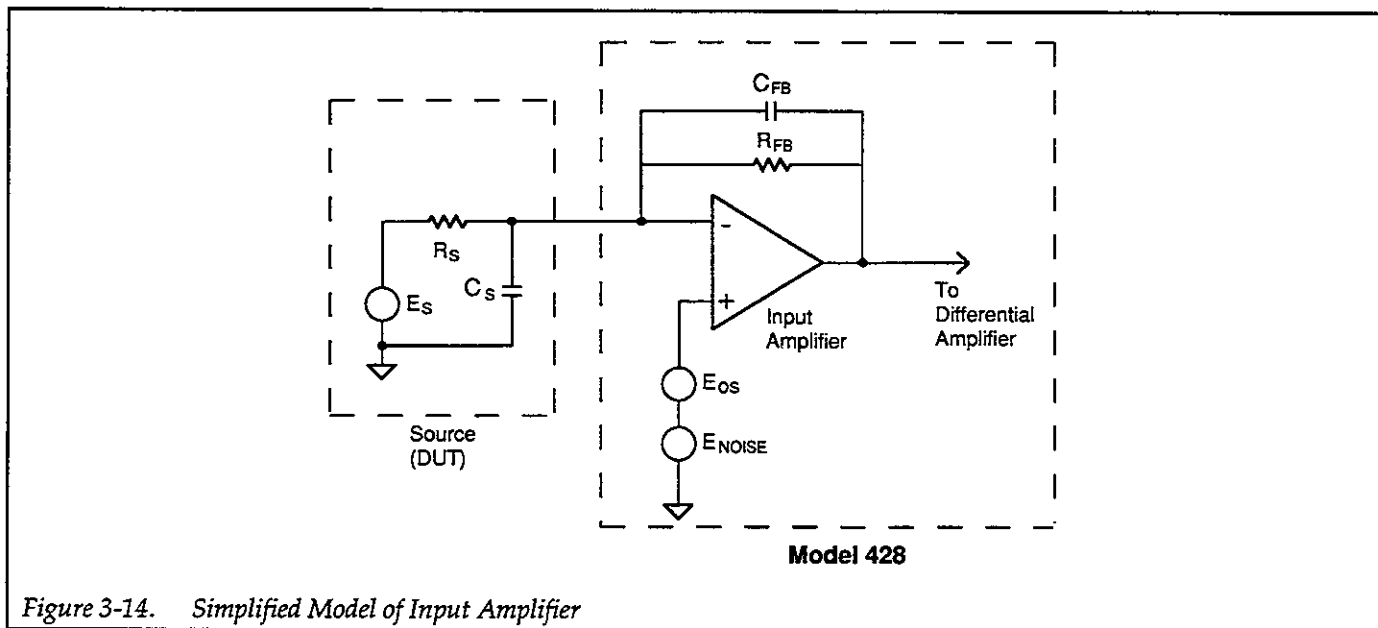

Figure 3-14. Simplified Model of Input Amplifier

Here, Z_{FB} is the feedback impedance made up of R_{FB} and C_{FB} , and Z_S is the source impedance formed by C_S and R_S , defined as follows:

$$|Z_{FB}| = \frac{R_{FB}}{\sqrt{1 + (2\pi f R_{FB} C_{FB})^2}}$$

and,

$$|Z_S| = \frac{R_S}{\sqrt{1 + (2\pi f R_S C_S)^2}}$$

From these relationships, it can be seen that, as the value of C_S increases, the source impedance at a given frequency decreases, resulting in increased noise gain of the input amplifier. If noise caused by source capacitance is found to be a problem, use the filter with a suitable rise time to reduce noise. Again, choose the rise time carefully so as to minimally affect the desired signal.

In cases where the source capacitance is relatively large, a series resistance can be added to the input between the source and input HI of the Model 428 to help minimize noise (note, however, that added resistance will increase rise time). A typical value for this series resistor is $1M\Omega$, but that value can be reduced to as low as $10k\Omega$ for larger capacitors, or where fast rise time important. Note that values less than $10k\Omega$ are not recommended.

3.13.3 Mechanically-Induced Noise

At higher gain settings, noise induced in the input amplifier by mechanical shock and vibration may be a problem. Such noise is usually the result of piezoelectric currents generated in insulators and other components. Piezoelectric currents are currents caused by mechanical stress on the components in question.

In order to minimize mechanically-induced noise, keep the Model 428 and input cables away from mechanical shocks and vibration sources such as motors and pumps. Simply striking the workbench or rack that holds the instrument with your hand or a hard object may result in noticeable transient noise signals. To avoid these problems, avoid touching the test equipment or moving input cables while making critical measurements. This type of noise is more likely to be a problem at 10^9 , 10^{10} , and 10^{11} gains.

In some cases, it may be necessary to shock-mount the current amplifier. One possible remedy might be to place the Model 428 on a shock-absorbing pad such as those available for phonograph turntables.

Finally, using the lowest gain setting possible will reduce any mechanically-generated noise. Where possible, increase the current source value, and then decrease the gain accordingly to minimize these effects while at the same time obtaining the desired output voltage from the current amplifier.

3.13.4 Cable Noise Currents

Noise currents can be also generated by bending or flexing the coaxial input cable. These currents, which are known as triboelectric currents, are generated by charges created between a conductor and insulator caused by friction.

To minimize cable noise currents, use only the recommended low-noise cable such as the Model 4801 for input connections to the Model 428. These cables are graphite-impregnated to reduce friction-generated currents.

In order to further reduce cable noise currents, tie down the cable connected to the Model 428 input to avoid flexing, and isolate the input cable from vibration sources such as motors and pumps. Also, avoid temperature extremes that could result in cable expansion and contraction.

3.13.5 Leakage Resistance

The effects of leakage resistance should be considered when making small current measurements from high-impedance sources. Any leakage resistance provides shunt paths for leakage currents that can result in inaccurate measurements.

The effects of leakage paths can be minimized by using a guarded test fixture, as shown in Figure 3-15. Since the Model 428 input amplifier uses a guarded configuration, it is effectively guarded at the input, and this guard connection can be carried through to the test fixture. Note that the test fixture input HI node should be properly insulated with Teflon® standoffs or other material with equivalent high resistance.

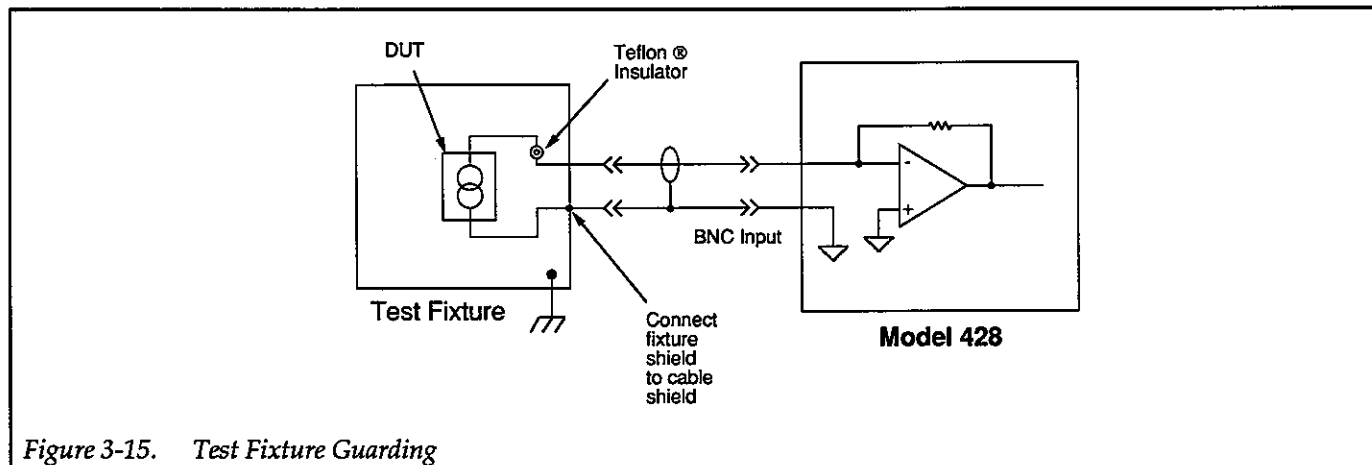

Figure 3-15. Test Fixture Guarding

3.13.6 Shielding

Proper shielding of all signal paths and devices under test is important to minimize noise pickup in many test systems. Otherwise, interference from such noise sources as line frequency and RF fields can seriously corrupt a measurement.

To assure proper shielding, use only coaxial cables for both input and output connections. Also be certain that the shield connection is carried through as close to the DUT as possible. Where possible, the DUT or current source should be placed inside a shielded enclosure, with the shield connected to the shield of the input cable.

3.13.7 Electromagnetic Interference (EMI)

The electromagnetic interference characteristics of the Model 428 Current Amplifier comply with the electromagnetic compatibility (EMC) requirements of the European Union (EU) directives as denoted by the CE mark. However, it is still possible for sensitive measurements to be affected by external sources. In these instances, special precautions may be required in the test setup.

Sources of EMI include:

- Radio and TV broadcast transmitters.
- Communications transmitters, including cellular phones and handheld radios.
- Devices incorporating microprocessors and high-speed digital circuits.
- Impulse sources as in the case of arcing in high-voltage environments.

The instrument, measurement leads, and other cables should be kept as far away as possible from any EMI sources. Additional shielding of the test fixture, signal leads, sources, and measuring instruments will often reduce EMI to an acceptable level. In extreme cases, a specially constructed screen room may be required to sufficiently attenuate the troublesome signal.

Many instruments, including the Model 428, incorporate internal filtering that may help reduce EMI effects in some situations. Increasing the filter rise time will often help to reduce EMI. In some cases, additional external filtering may be required. Keep in mind, however, that additional filtering or increased rise time may have detrimental effects on the desired signal.

3.13.8 Ground Loops

When two or more instruments are connected together, care must be taken to avoid unwanted signals caused by ground loops. Ground loops usually occur when instrumentation is connected to other instrumentation with more than one signal return path such as power line ground. As shown in Figure 3-16, the resulting ground loop causes current to flow through the instrument LO signal leads and then back through power line ground. This circulating current develops a small but undesirable voltage between the LO terminals of the two instruments. This voltage will be added to the signal voltage, affecting the accuracy of the measurement.

Figure 3-17 shows how to connect several instruments together to reduce this type of ground loop problem.

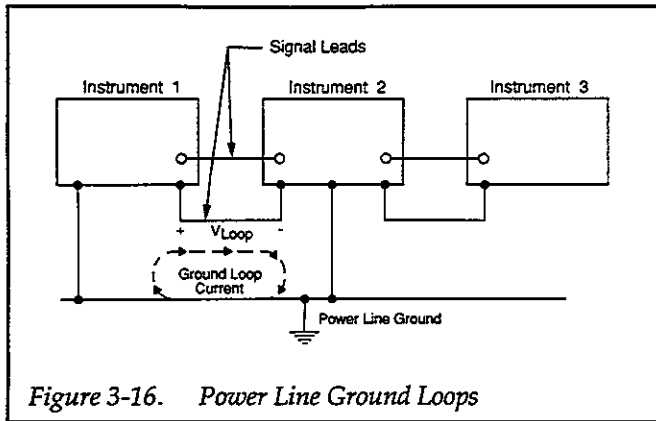

Figure 3-16. Power Line Ground Loops

Here, only one instrument is connected to power line ground.

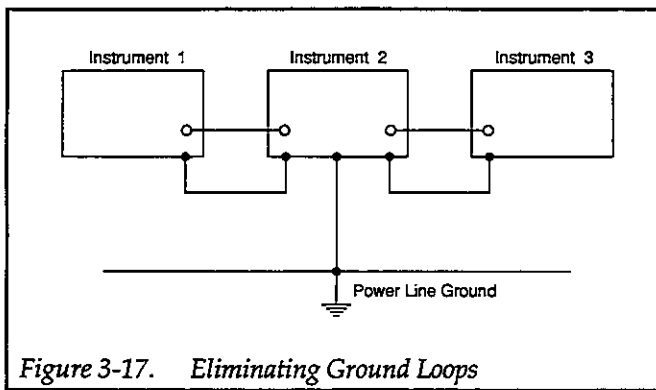

Figure 3-17. Eliminating Ground Loops

The output connector, however, is not isolated from chassis ground, so possible ground-loop problems may occur due to output connections. Also, all other instruments in the test setup may not have isolated terminals or connectors. If the current source is grounded, it may be necessary to isolate the device from power line ground.

When in doubt, consult the manual for all instrumentation in the test setup.

3.14 APPLICATIONS

The Model 428 can be used with a variety of instruments to perform many different tests involving current measurements. The paragraphs below discuss several possible applications for the Model 428. These applications can be automated by using a Model 428-PROG over the IEEE-488 bus in conjunction with other bus-interfaceable instruments.

3.14.1 High-Speed Capacitor Leakage Tests

Basic Leakage Test

Typically, capacitor leakage is measured by connecting a voltage source across the capacitor, and then measuring the current through the capacitor with a picoammeter, as in the example of Figure 3-18. The resistor R is used to minimize noise, as discussed in paragraph 3.13.2. This method works quite well for a variety of test conditions, but the reading rate of the typical picoammeter is usually too slow for a high-speed leakage test system.

High-Speed Leakage Test System

For greater speed and test flexibility, the Model 428 can be combined with a high-speed DMM, a voltage source, and a scanner to rapidly test a number of capacitors for leakage. Figure 3-19 shows an example of such a test system. The functions of the various system components include:

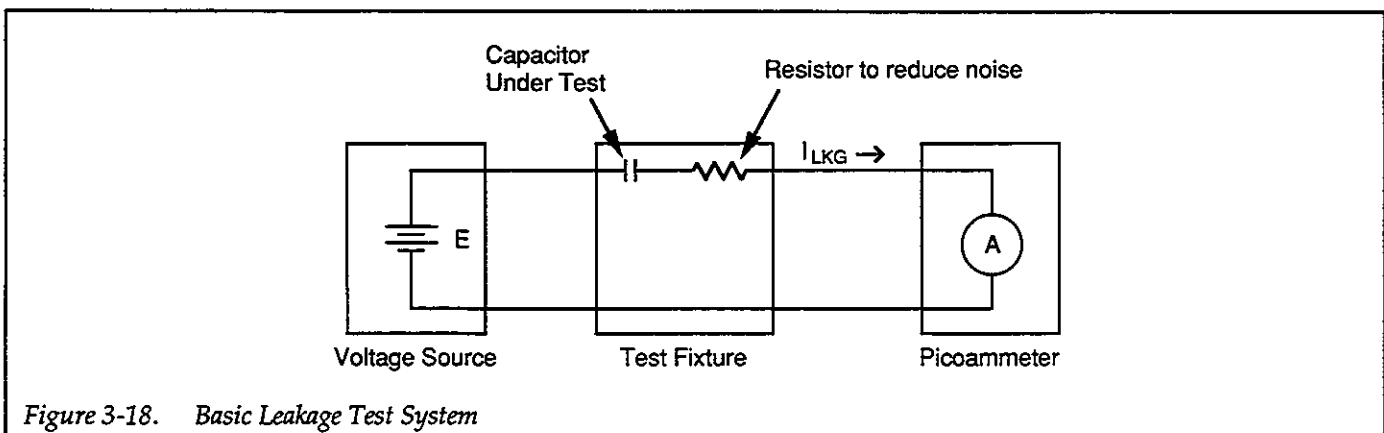

Figure 3-18. Basic Leakage Test System

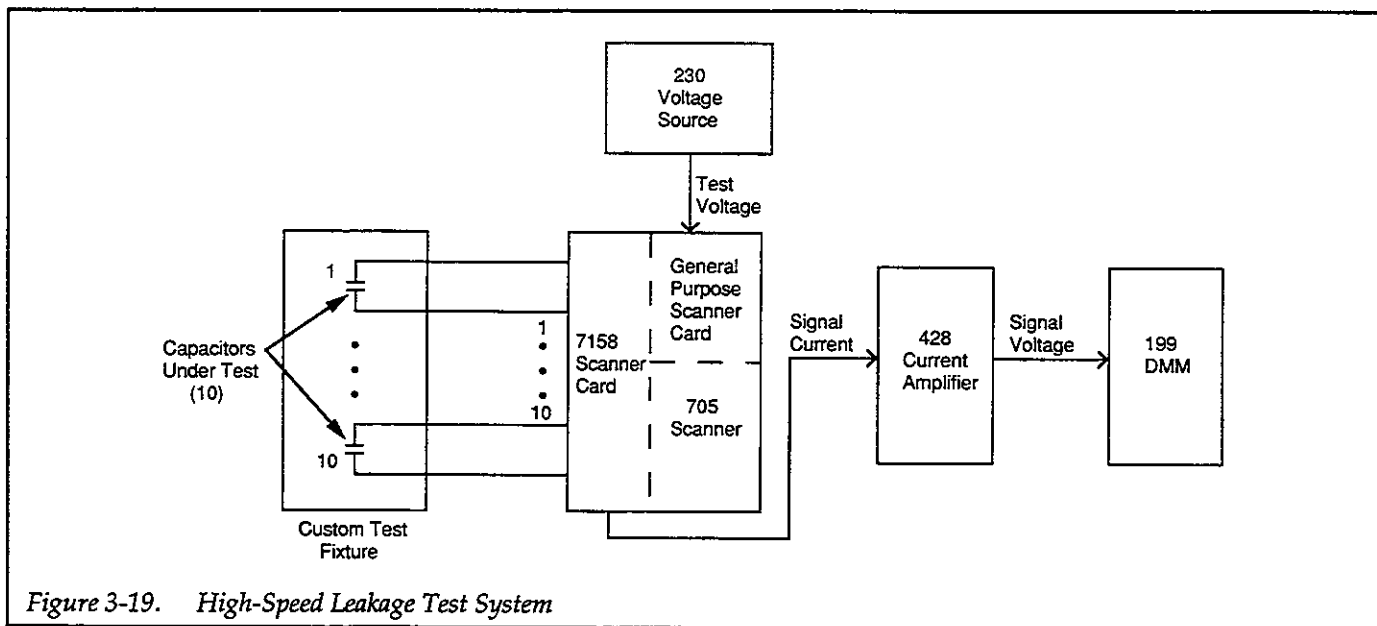

Figure 3-19. High-Speed Leakage Test System

Model 230 Voltage Source: Supplies the test voltage to the capacitor under test. The Model 230 can be programmed to step among different test voltages if desired.

Model 705 Scanner and Scanner Cards: The Model 705 Scanner can hold two cards of 10 channels each, and five scanners can be daisy chained together to expand the number of channels. Each Model 7158 card can switch 10 devices with <math><1\text{pA}</math> specified offset current. A Model 7056 General Purpose Scanner card can be used for lower voltages (<math><150\text{V}</math>), or a Model 7054 High Voltage Scanner Card can be used for voltages as high as 1100V.

Model 428 Current Amplifier: Amplifies the current and converts it to a voltage that can be measured by the DMM.

Model 199 DMM: The Model 199 measures the output voltage from the current amplifier. The DMM has a 500-reading buffer, which would allow the unit to store readings for later recall and display after the test has been completed.

Figure 3-20 shows the equivalent circuit of the test system. Note that only two of the 10 channels for the scanner cards are shown. Resistors R1 and R2 are included to limit current and reduce noise. Typically values of 100k Ω to 1M Ω . R3 and R4 provide a discharge path and have a value of 100k Ω .

In order to test C1, close K1 for the required soak (charging) time, then close K2 and make the measurement. The remaining capacitors would be tested in the same way. Soak and measurement sequences could be alternated in order to minimize overall measurement time.

Automated Leakage Test System

The system described above could be easily integrated into an automated test system controlled over the IEEE-488 bus. Figure 3-21 shows the overall configuration of such an automated system. Typical controllers include the HP Series 200 and 300 computers and IBM PC, AT or compatibles. Either type must, of course, be equipped with an IEEE-488 interface.

Measurement Considerations

As with any low-current test system, care must be taken to ensure that none of the connecting cables or test fixture add error currents. To avoid such problems, use only low-noise coaxial cables, and make certain that the test fixture is designed with high-impedance insulating characteristics.

For larger capacitor values, it may be necessary to add a series resistor to input HI of the current amplifier to reduce noise. A typical value for this resistor is 1M Ω , but that value could be reduced for shorter settling times. Enable zero check while capacitors are charging to minimize Model 428 overload recovery time.

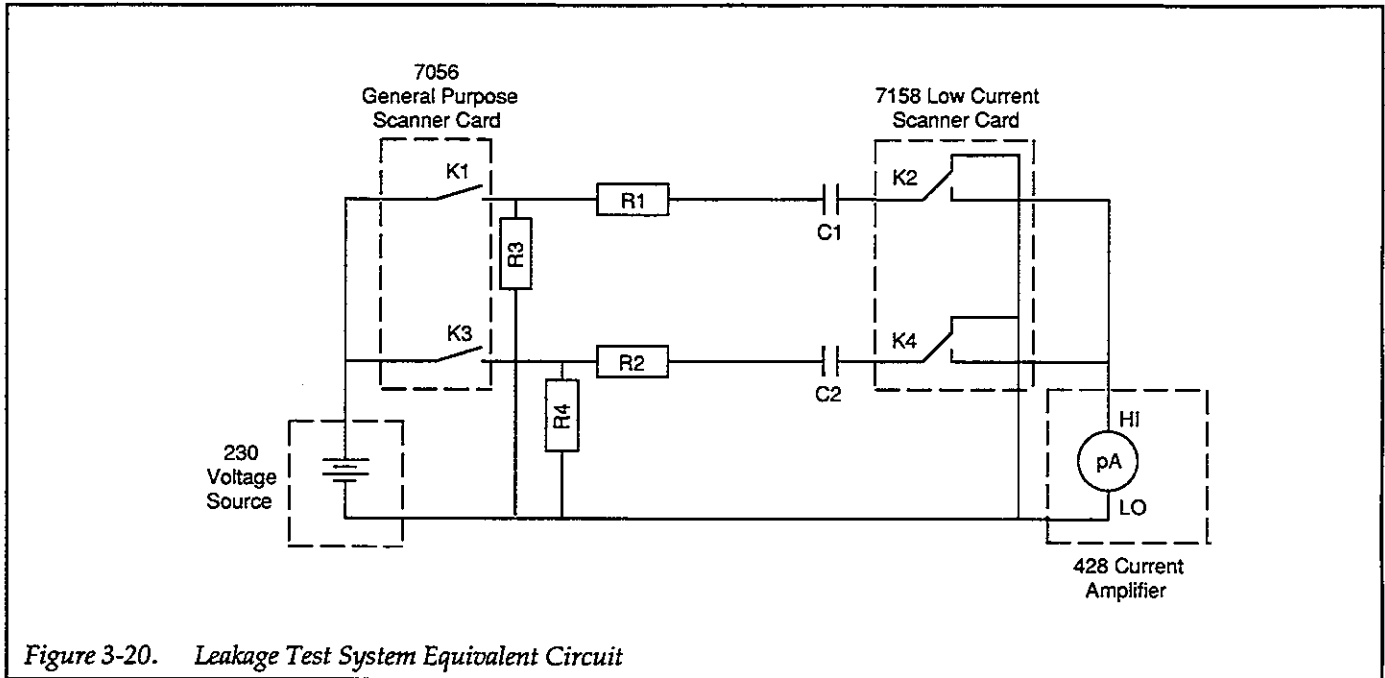

Figure 3-20. Leakage Test System Equivalent Circuit

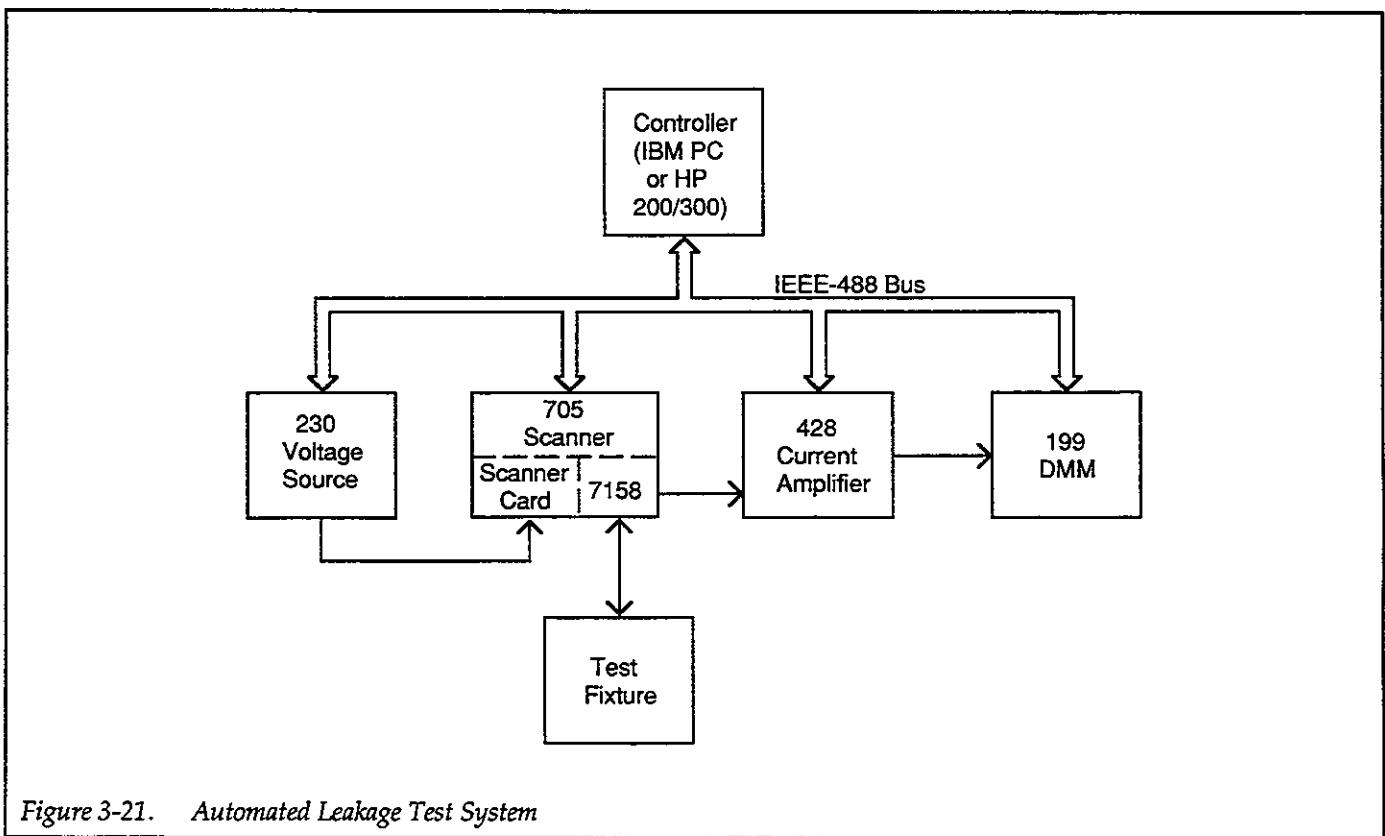

Figure 3-21. Automated Leakage Test System

Finally, the noise performance of the voltage source is critical to good overall noise performance. The Model 230 has good noise performance that should be adequate for many situations, but, for situations requiring lower noise, a Model 236 Source Measure Unit could be used instead of the Model 230.

3.14.2 Current Waveform Acquisition

The high speed of the Model 428 makes it an ideal instrument for amplifying fast current waveforms. A variety of transient current waveforms can be captured by combining the current amplifier with an appropriate waveform digitizer.

Current Acquisition System

Figure 3-22 shows a typical current waveform acquisition system. In addition to the Model 428, the system also includes a Model 194A High Speed Voltmeter, which is used to acquire and store the signal waveform after current-to-voltage conversion by the Model 428. The Model 194A can sample at rates as high as 1M samples/second (8-bit resolution) or 100k samples/second (16-bit resolution), and it can store 32k samples with 16-bit resolution or 64k samples with 8-bit resolution. Built-in math routines allow waveform analysis functions such as average, standard deviation, integral and TRMS. The Model 194A can drive a variety of graphing devices such as plotter, strip chart recorders, CRTs, and oscilloscopes to allow easy generation of curves from acquired waveform data, or it can be connected to a computer for even greater flexibility.

A Current Acquisition Practical Example

One possible use for the transient current acquisition system would be to test for self-healing oxide breakdown in MOSFET wafers. This test is performed by ramping up the test voltage across an MOS test capacitor located on a semiconductor wafer until breakdown occurs, and then capturing the resulting transient breakdown current waveform. This phenomenon differs from breakdown conditions seen in many other semiconductor tests in that the breakdown period is very brief and transient in nature. When breakdown occurs, the resulting catastrophic conditions cause self-healing, restoring the oxide to its normal state after the brief breakdown period.

Figure 3-23 shows a typical system for testing oxide breakdown. In addition to the Models 428 and 194A, the system also includes a Model 236 or 237 Source Measure Unit to supply the excitation voltage. The Model 236 can supply DC, staircase, or pulse voltage waveforms up to $\pm 110V$. The Model 237 has similar capabilities except that its voltage range extends to $\pm 1100V$. The necessary ramp voltage can be approximated by choosing a staircase waveform with very small steps.

The typical value for the device resistance, R_{DUT} , is between $100k\Omega$ and $1M\Omega$, while the typical value for C_{DUT} is between $100pF$ and $100nF$. In some cases, it may be necessary to add an external series resistor to raise the circuit time constant to stretch the duration of the current waveform because typical duration may be shorter than $10\mu sec$.

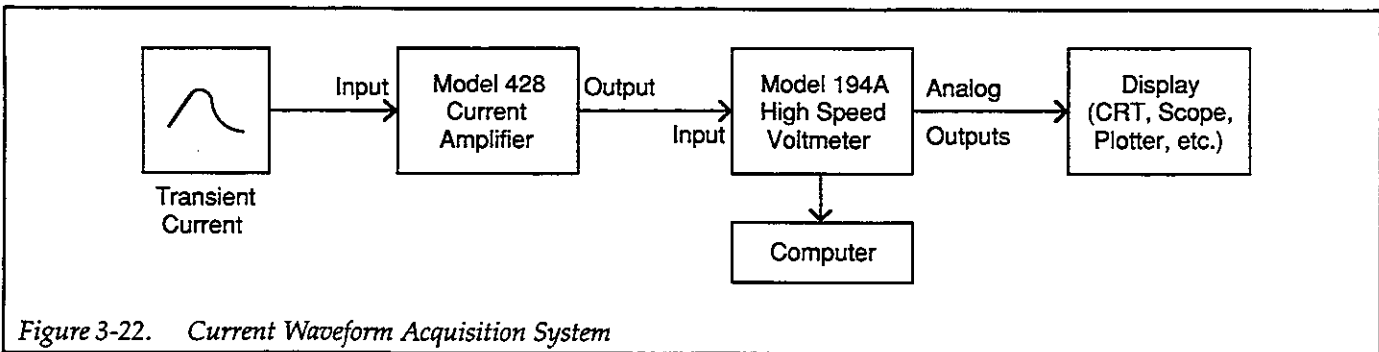
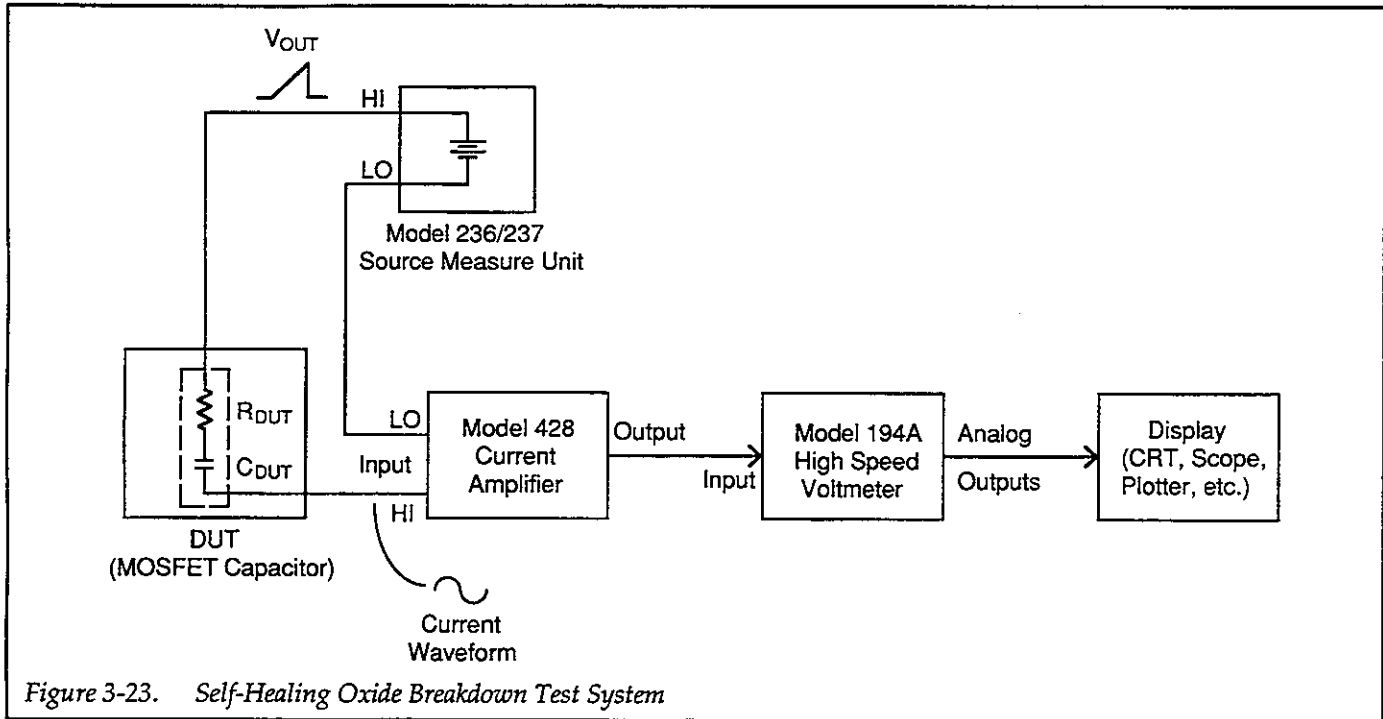

Figure 3-22. Current Waveform Acquisition System



3.14.3 Using the Model 428 as a Picoammeter

The auto-suppression feature of the Model 428 can be used to make current measurements. While this method may not be as accurate as using a conventional picoammeter, it will yield satisfactory results in many cases.

To measure current, first connect the signal current to be measured, then disable zero check. Select an appropriate gain setting, then press SHIFT AUTO to perform auto-suppression. Press SETUP CURRENT SUPPRESS to view the suppression value, which is the value of the signal current.

Leakage Tests

Auto suppress can be used in conjunction with the voltage bias source to perform basic leakage tests on a variety of semiconductor devices such as diodes, bipolar transistors, and FETs. Figure 3-24 shows an example of test connections for measuring I_{CBO} leakage current on a transistor. In order to perform such tests, set the voltage bias source to the desired value (usually $\pm 5V$), then autosuppress the signal current and view the current on the front panel display.

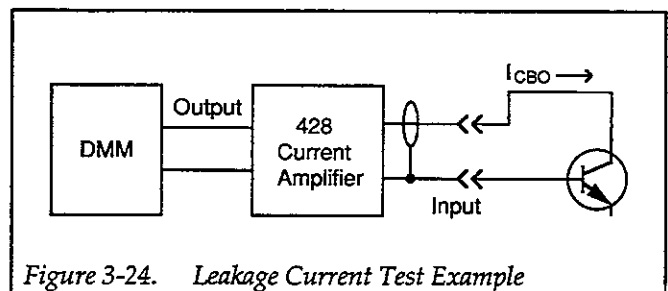

SECTION 4

IEEE-488 Reference

4.1 INTRODUCTION

This section contains reference information on programming the Model 428-PROG over the IEEE-488 bus. Detailed instructions for all programmable functions are included; however, information concerning operating modes presented elsewhere is not repeated here. Refer to Sections 2 and 3 for information not found in this section.

General information on the IEEE-488 bus is located in the Appendix.

This section is arranged as follows:

4.2 Device-dependent Commands: Describes the majority of the commands that control the instrument over the bus.

4.3 General Commands: Covers the general commands required for such operations as placing the unit in remote and returning the instrument to default conditions.

4.4 Bus Connections: Details connecting the instrument to the IEEE-488 bus.

4.5 Primary Address Programming: Gives the procedure for programming the primary address from the front panel.

4.6 Front Panel Aspects of IEEE-488 Information: Covers front panel aspects like display messages, status indicators, and use of the LOCAL key.

4.2 DEVICE-DEPENDENT COMMAND PROGRAMMING

IEEE-488 device-dependent commands are the most important commands associated with instrument programming because they control most instrument operating modes. All Model 428 front panel operations (such as gain and filter rise time), as well as some operations not available from the front panel (like SRQ and terminator) can be programmed with these commands.

Command Syntax

Each command is made up of a single ASCII capital letter followed by one or more numbers representing an option or numeric parameter of that command. For example, the gain can be set over the bus by sending the letter "R" followed by a number representing the gain option. R5X would be sent to program a gain of 10^5V/A .

Only one command (the S command) has two parameters that must be separated by a comma. For example, an S0,7X command programs the suppress value and range. In this case, the 0 selects a suppress value of zero, while the 7 parameter selects the $\pm 5\text{mA}$ suppress range.

Multiple Commands

A number of commands can be grouped together in one command string, which is generally terminated by the "X" character. This character tells the instrument to execute the command or command string, as described in paragraph 4.2.17. Commands sent without the execute character will not be executed at that particular time, but they will be stored within an internal command buffer for later execution when the execute character is later received. Note that any spaces (ASCII 32) in the command string will be ignored.

Sending Commands Without Options

If a command letter is sent without an option, the setting defaults to the current value. For example, sending PX (filter on/off) leaves the filter in its current state.

Numeric Option Format

Some commands such as S (suppress value and range) and V (voltage bias value) require a numeric option that can be sent in fixed or floating-point formats. For example, the values below will all yield a value of 1:

1
+1
1.
1.00
1e00
1e
1E00
0.001E3
.0000000001E10
100000000E-8

Leading blank spaces and zeroes are ignored.

Invalid Commands

If an invalid command is sent as part of the command string, no commands in the string will be executed. Under these conditions, the instrument will display a front panel error message (IDDC or IDDCO) and it can be programmed to generate an SRQ (Service Request), as discussed in paragraph 4.2.9.

Some typical examples of valid command strings include:

R0X	Single command followed by execute command.
Y3T0P0X	Multiple command string.
Z 1X	Space is ignored,
S0,7X	Multiple-parameter command string (parameters separated by comma).

Typical invalid command strings include:

F1X	Invalid command, as F is not one of the instrument's valid commands.
K4X	Invalid command option because 4 is not an option of the K command.

Device-dependent Command Summary

Model 428 device-dependent commands are summarized in Table 4-1, which also lists respective paragraphs where more detailed information on each command may be found.

Order of Command Execution

Device-dependent commands are not necessarily executed in the order received. Rather, the instrument executes them in a specific order, as summarized in Table 4-2. The order shown in the table assumes that the "X" character appears only once at the end of a multiple command string.

If you wish to force a particular order of execution, simply include the execute (X) character after each command-option grouping in the command string. For example, the following string would be executed in the received order:

R0XT2XM1XK0X

Table 4-1. Device-dependent Command Summary

Mode	Command	Description	Para.
Display intensity	A0 A1 A2	Normal Dim Off	4.2.1
Bias on/off	B0 B1	Turn voltage bias off Turn voltage bias on	4.2.2
Zero check zero correct	C0 C1 C2	Turn zero check off Turn zero check on Perform auto zero correct	4.2.3
Display	DaaaaX Dx	Display string aaa (10 max.) Return to normal display	4.2.4
Hit key	H1 H2 H3 H4 H5 H6 H7 H8 H9 H10 H11 H12 H13 H14 H15 H16 H17	DISPLAY INTENSITY LOCAL SHIFT MENU ZERO CHECK SETUP GAIN SETUP FILTER RISE TIME SETUP CURRENT SUPPRESS SETUP VOLTAGE BIAS ENABLE GAIN X10 ENABLE FILTER ENABLE CURRENT SUPPRESS ENABLE VOLTAGE BIAS ◀ ▶ Knob rotation counter clockwise Knob rotation clockwise	4.2.5
Self-test	J0 J1	Test ROM and RAM only Test ROM, RAM, and display	4.2.6
EOI, hold-off	K0 K1 K2 K3	Enable EOI, enable holdoff on X Disable EOI, enable holdoff on X Enable EOI, disable holdoff on X Disable EOI, disable holdoff on X	4.2.7
Save/recall	L0 L1 L2	Restore factory defaults and save Save configuration as power on Restore power-on conditions	4.2.8
SRQ mask	M1 M2 M4 M8 M16 M32	Overload Front panel key press Not used Not used Ready for command U1 error	4.2.9

Device-dependent Command Summary (Cont.)

Mode	Command	Description	Para.
Suppression on/off	N0 N1 N2	Turn suppression off Turn suppression on Automatic suppress	4.2.10
Filter	P0 P1	Turn filter off Turn filter on	4.2.11
Gain	R0 R1 R2 R3 R4 R5 R6 R7 R8 R9 R10	10^3 V/A gain 10^3 V/A gain 10^3 V/A gain 10^3 V/A gain 10^4 V/A gain 10^5 V/A gain 10^6 V/A gain 10^7 V/A gain 10^8 V/A gain 10^9 V/A gain 10^{10} V/A gain	4.2.12
Suppression value, range	S, 0 Sn, 1 Sn, 2 Sn, 3 Sn, 4 Sn, 5 Sn, 6 Sn, 7 Sn, 8 Sn, 9 Sn, 10	Enable auto-ranging (bus only) n = value, ± 5 nA range n = value, ± 50 nA range n = value, ± 500 nA range n = value, ± 5 μ A range n = value, ± 50 μ A range n = value, ± 500 μ A range n = value, ± 5 mA range IDDCO IDDCO Disable auto-ranging (bus only)	4.2.13
Rise time	T0 T1 T2 T3 T4 T5 T6 T7 T8 T9	10 μ sec 30 μ sec 100 μ sec 300 μ sec 1msec 3msec 10msec 30msec 100msec 300msec	4.2.14
Alternate output	U0 U1 U2 U3 U4	Send machine status word Send error status word Send bias value Send total gain Send model number, revision	4.2.15
Bias value	Vn	$-5 \leq n \leq +5$ V, 2.5mV resolution	4.2.16

Device-dependent Command Summary (Cont.)

Mode	Command	Description	Para.
X10 gain on/off	W0	Turn X10 gain off	4.2.17
	W1	Turn X10 gain on	
Execute	X	Execute DDCs previously sent	4.2.18
Terminator	Y0	<CR><LF>	4.2.19
	Y1	<LF><CR>	
	Y2	<CR>	
	Y3	<LF>	
Auto-filter	Z0	Turn auto-filter off	4.2.20
	Z1	Turn auto-filter on	

Table 4-2. Order of Command Execution

Order	Command	Description
1	M	Set the SRQ mask
2	K	Select EOI and holdoff on X
3	A	Select display intensity
4	R	Set gain
5	W	Filter on/off
6	V	Program bias voltage value
7	B	Turn bias voltage on or off
8	T	Select filter rise time
9	P	Turn X10 gain on or off
10	Z	Select auto-filter when filter is off
11	S	Set current suppress value, range
12	N0/1	Suppress on/off
13	C0/1	Zero check on/off, zero correct
14	C2	Zero correct
15	N2	Auto suppress
16	Y	Select terminator character
17	J	Execute self-test
18	U	Request alternate output (status words)
19	D	Display message
20	L*	Save/recall setup, restore factory defaults
21	H	Hit front panel key

*Restoring defaults overrides any other command (except H, which is executed last). Including a save setup command with other commands causes the new setup resulting from the execution of all other commands (except H) to be saved.

Controller Programming

The programming instructions covered in this section use examples written with Hewlett-Packard BASIC version 4.0. This language was chosen because of its versatility in controlling the IEEE-488 bus.

NOTE

Controller programming information for using the IBM PC interfaced through the Capital Equipment Corporation (CEC), I/O Tech, and National IEEE-488 interfaces is located in the Appendix.

Two key HP BASIC commands required for most Model 428 programming are the OUTPUT and ENTER statements. The OUTPUT statement transmits commands to the Model 426 and takes on the following form:

OUTPUT 722; A\$

where 722 designates the interface select code (7) and primary address (22), and A\$ is a string of characters representing Model 428 device-dependent commands.

Similarly, ENTER reads information from the Model 428 and has the form:

ENTER 722; A\$

Again, 722 is the interface select code and primary address, and A\$ is the string variable into which information is placed.

Additional HP BASIC statements for general bus commands are covered in paragraph 4.3.

Command Buffer Length

The command buffer is 128 characters in length. From a practical standpoint, however, there is almost no limitation as to the number of characters you can send before the "X" character. After 128 characters are sent, however, bus transmission may slow down considerably because the instrument is still in the process of parsing previous commands.

4.2.1 A — Display Intensity

Purpose	To program the display intensity to normal, dim, or off settings.	
Format	An	
Parameters	A0 Normal display A1 Dim display A2 Turn display off	
Default	Upon power-up, or after receiving a DCL, SDC, or L2X command, the display intensity returns to the programmed default setting. The factory default setting is A0 (normal display).	
Description	The A command allows control of display intensity. Thus, the A command performs the same operation as the front panel DISPLAY INTENSITY key. The normal intensity is intended for normal ambient room light, the dim setting is for low-light situations, and the off position is intended for photosensitive applications.	
Programming Note	The POWER indicator remains on at a very dim level when display intensity is off.	
Programming Examples	10 OUTPUT 722;"A2X" 20 OUTPUT 722;"A1X" 30 OUTPUT 722;"A0X"	! Turn display off ! Select dim display. ! Select normal display

4.2.2 B — Voltage Bias On/Off

Purpose	To turn the voltage bias output on or off	
Format	Bn	
Parameters	B0 Turn voltage bias off B1 Turn bias on	
Default	Upon power-up, or after receiving a DCL, SDC, or L2X command, the instrument defaults to the programmed setting when last turned off. The factory default setting is B0 (voltage bias off).	
Description	The B command allows you to turn the voltage bias source on or off over the bus, performing the same functions as the front panel ENABLE VOLTAGE BIAS key. The bias voltage is applied between the HI and LO terminals of the INPUT jack. See paragraph 3.9 for voltage bias details.	
Programming Notes	<ol style="list-style-type: none">1. Zero check must be disabled before the bias voltage will appear across the INPUT jack HI and LO terminals.2. The voltage bias value is programmed with the V command (paragraph 4.2.16).3. The maximum voltage bias value is $\pm 5V$, and the resolution is $\pm 2.5mV$.4. When a positive voltage is programmed, the voltage at INPUT HI will be positive with respect to INPUT LO.5. The programmed bias voltage affects the maximum output voltage. See paragraph 3.4.5.	
Programming Examples	10 OUTPUT 722;"B0X"	! Disable voltage bias
	20 OUTPUT 722;"B1X"	! Enable voltage bias

4.2.3 C — Zero Check and Zero Correct

Purpose	To zero check and zero correct the instrument	
Format	Cn	
Parameters	C0 Turn zero check off C1 Turn zero check on C2 Perform automatic zero correct	
Default	Upon power-up, or after receiving a DCL, SDC, or L2X command, the instrument returns to the programmed default setting. The factory default setting is C1 (zero check on).	
Description	<p>The C0 and C1 commands control whether zero check is on or off. These two commands perform essentially the same functions as the front panel ZERO CHECK key. When zero check is turned on (C1), suppression, bias voltage, and X10 gain are all disabled. When zero check is turned off, these modes are automatically returned to their previous settings.</p> <p>When zero correction is performed (C2), zero check is automatically enabled (if disabled), and the correction process is performed. Zero check then returns to its previous state. Sending C2 performs the same operation as pressing SHIFT CORRECT on the front panel.</p>	
Programming Notes	<ol style="list-style-type: none"> 1. A correction error will occur if the offset is too large to correct. The front panel will display the "CORECT ERR" message, and the instrument can be programmed to generate an SRQ under these conditions. Refer to paragraphs 4.2.9 and 4.2.15 for details. 2. Zero check should be left enabled when the instrument is turned on and not in use to avoid possible problems from erroneous signals. 3. Zero check must be disabled (C0X) to obtain an output signal, or to apply the programmed bias voltage to the device connected to the input. 4. Zero correct constants are not automatically saved in E²ROM. Use the L1X command (paragraph 4.2.8) to save new correction constants. 	
Programming Examples	10 OUTPUT 722 ;"C1X" 20 OUTPUT 722 ;"C2X"	! Enable zero check Examples ! Zero correct unit

4.2.4 D — Display Message

Purpose To display ASCII messages on the front panel

Format Daaa...aX

Parameters

Daaa...aX	Display characters "aaa", where "aaa" represents printable ASCII characters (10 maximum).
DX	Return display to normal operation

Default Upon power-up, or after receiving a DCL, SDC, L0X or L2X command, the display always returns to normal.

Description The D command lets you display messages on the front panel. Up to 10 characters can be displayed by simply following the appropriate D command with ASCII characters. Characters that can be displayed include: 0-9, upper-case letters A-Z, some lower-case letters, spaces (ASCII 32), arithmetic characters, and most punctuation symbols. If more than 10 characters are sent between D and X, only the first 10 will be displayed – the rest will be ignored. If less than 10 characters are sent, the message will be left-justified, with the rest of the display remaining blank.

Programming Notes

1. Error messages overwrite a displayed user message.
2. The following lower-case letters can be displayed: b c d h i m n o r u v w. The rest will be converted to upper case.
3. In addition to using DX, the display can be returned to normal by performing one of the following: sending DCL or SDC, returning the Model 428 to the local state (sending GTL or pressing LOCAL), or restoring power-up defaults or factory defaults with the L command.

Programming Examples

```
10 REMOTE 722           ! Put 428 in remote
20 OUTPUT 722 ;"DMODEL 428X" ! Display "MODEL 428"
30 PRINT "Press 'Cont'"  ! Prompt to continue
40 PAUSE
50 OUTPUT 722 ;"DX"      ! Return display to normal
60 END
```

4.2.5 H — Hit Button

Purpose To emulate front panel control sequences

Format Hn

Parameters	Command	Front Panel Control
	H1	DISPLAY INTENSITY
	H2	LOCAL
	H3	SHIFT
	H4	MENU
	H5	ZERO CHECK
	H6	SETUP GAIN
	H7	SETUP FILTER RISE TIME
	H8	SETUP CURRENT SUPPRESS
	H9	SETUP VOLTAGE BIAS
	H10	ENABLE GAIN X10
	H11	ENABLE FILTER
	H12	ENABLE CURRENT SUPPRESS
	H13	ENABLE VOLTAGE BIAS
	H14	◀
	H15	▶
	H16	Rotate knob one click counterclockwise
	H17	Rotate knob one click clockwise

Description The H command allows you to emulate virtually any front panel control sequence, including those not available by using other IEEE-488 commands (for example, displaying menu items or reprogramming the IEEE-488 primary address).

Programming Note To force a multiple button command sequence, include the X character after each H command (see programming example below).

Programming Examples

```

10 REMOTE 722                ! Put 428 in remote.
20 OUTPUT 722 ;"H4X"        ! "Press" MENU key
30 PRINT "Press 'Cont'"    ! Prompt to continue
40 PAUSE
50 OUTPUT 722 ;"H3XH4X"    ! "Press" SHIFT EXIT
60 END

```

4.2.6 J — Self-test

Purpose To test RAM, ROM, and the front panel display

Format Jn

Parameters
J0 Test RAM and ROM only
J1 Test RAM, ROM, and front panel display

Description The J0 and J1 commands are similar in that they both test RAM and ROM. The J1 command adds the display self-test and performs the same function as the front panel MENU SELFTEST option.

You can check the results of the self-test by noting the status of the J command field in the U0 status word (paragraph 4.2.15). Self-test failure can also be checked by noting the state of the self-test bit in the U1 error word, and the instrument can be programmed to generate an SRQ if the self-test fails (paragraph 4.2.9).

Programming Note The instrument holds off bus operation with the NRFD line during self-test operation (if enabled). Thus, no commands can be sent during the self-test if hold-off on X is enabled. The J0 test takes only a couple seconds, but the J1 test takes more than 10 seconds to complete, and it may cause a controller time-out.

Programming Examples

10	OUTPUT 722;“J0X”	! Test RAM and ROM only
20	OUTPUT 722;“J1X”	! Perform RAM,ROM,display test

4.2.7 K — EOI and Bus Hold-Off

Purpose	To enable/disable EOI and bus hold-off on X.	
Format	Kn	
Parameters	K0 Enable EOI	Enable bus hold-off on X
	K1 Disable EOI	Enable bus hold-off on X
	K2 Enable EOI	Disable bus hold-off on X
	K3 Disable EOI	Disable bus hold-off on X
Default	Upon power-up, or after receiving a DCL, SDC, or L2X command, the instrument defaults to the previously-programmed power-up value. The factory default is K0 (both EOI and bus hold-off on X enabled).	
Description	<p>The EOI line provides one method to positively identify the last byte in the data string sent by the instrument. When enabled, EOI is asserted with the last byte the instrument sends over the bus.</p> <p>Bus hold-off allows the instrument to temporarily hold up bus operation via the NRFD line when it receives the X character until all commands are processed. Typical hold-off times are listed in Appendix G.</p>	
Programming Notes	<ol style="list-style-type: none"> 1. Some controllers rely on EOI to terminate their input sequences. Suppressing EOI may cause the controller input sequence to hang up. 2. When enabled, EOI is asserted with the last byte in the terminator (if enabled). 3. When bus hold-off is enabled, all bus activity is held up for the duration of the hold-off period – not just the activity associated with the Model 428. 	
Programming Examples	10 OUTPUT 722; "K1X"	! No EOI, hold-off on X
	20 OUTPUT 722; "K2X"	! Send EOI with last byte, do not hold-off on X

4.2.8 L — Save/Recall Configuration

Purpose To save and recall instrument configuration, and to restore factory defaults

Format Ln

Parameters
 L0 Restore factory default conditions and save (L1)
 L1 Save current configuration as power-up default
 L2 Restore power-on default conditions

Power-on Default Upon power-up, or after a DCL, SDC, or L2 command, the instrument assumes the conditions saved by the L1 command.

Factory Default	Mode	Factory Default State
	DISPLAY INTENSITY	Normal (A0)
	CURRENT SUPPRESSION	0.000mA, off (S0,7N0)
	GAIN	10 ³ V/A (R3)
	GAIN X10	Off (W0)
	FILTER	Off (P0)
	FILTER RISE TIME	10μsec (T0)
	VOLTAGE BIAS	0.000V, off (V0,B0)
	ZERO CHECK	On (C1)
	AUTO-FILTER	On (Z1)
	SRQ	Disabled (M0)
	EOI	EOI and hold-off enabled (K0)
	Terminator	<CR><LF> (Y0)

Description The L command allows you to save and recall instrument configuration. The table above lists those operating modes that can be saved and recalled. The L0 command allows you to restore those factory default conditions listed above and then save them as power-on default. L1 and L2 save and recall respectively.

Programming Notes

1. The L command does not affect the programmed primary address.
2. L1 will save the current zero correct constants.
3. L2 does not recall old zero correct constants.

Programming Examples

10	OUTPUT 722 ;"L1X"	! Save power-on configuration
20	OUTPUT 722 ;"L2X"	! Recall power-on configuration

4.2.9 M — SRQ Mask and Serial Poll Byte Format

Purpose To program which conditions generate an SRQ (service request)

Format Mn

Parameters

M0	SRQ disabled
M1	Overload
M2	Front panel key press
M4	Not used
M8	Not used
M16	Ready for command
M32	Error

Default Upon power-up, or after receiving a DCL, SDC, or L2X command, the instrument returns to the programmed power-on default value. The factory default is M0 (SRQ disabled).

Description The SRQ command selects which conditions cause the Model 428 to generate an SRQ (service request). Once an SRQ is generated, the serial poll byte can be checked to determine if the Model 428 was the instrument that generated the SRQ and, if so, what conditions caused it to do so.

An 8-bit SRQ mask determines which conditions cause an SRQ to be generated. (See Figure 4-1.) By sending the appropriate M command, you can set the bit or bits to enable SRQ generation if those particular conditions occur. The bits in the mask operate as follows:

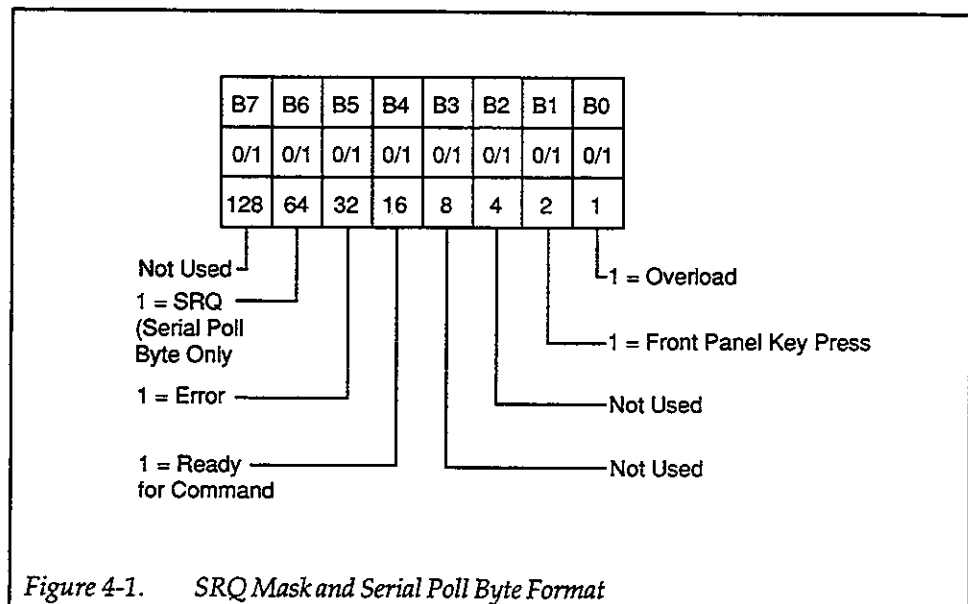

Figure 4-1. SRQ Mask and Serial Poll Byte Format

- M1—an overload condition has occurred
- M2—a front panel key was pressed
- M16—the Model 428 is ready to be sent another command
- M32—one of the following U1 errors has occurred (paragraph 4.2.15):

- IDDC (Invalid Device-dependent Command)
- IDDCO (Invalid Device-dependent Command Option)
- No remote
- Self-test failed
- Suppression conflict error
- Input current too large to suppress
- Auto-suppression attempt with zero check on
- Zero correct failed
- E²PROM checksum error
- Overload condition detected
- Gain/rise time conflict

Serial Poll Byte

The general format of the serial poll byte is shown in Figure 4-1. Note that all bits except for bit 6 correspond to the bits in the SRQ mask. These bits are set and cleared under the following conditions:

Bit	Set by	Cleared by
7	NA	NA
6	SRQ by 428	Reading serial poll byte
5	U1 error	Reading U1 status
4	Ready for command	Receipt of "X" character
3	NA	NA
2	NA	NA
1	Front panel key press	Reading U0 status
0	Overload	No overload

Programming Notes

SRQ Mask

1. The instrument may be programmed to generate an SRQ for more than one set of conditions simultaneously. To do so, simply add up the decimal bit values for the required SRQ conditions. For example, to enable SRQ under overload (M1) and U1 error conditions (M32), send M33X.
2. Send M0X to disable SRQ. This command clears all bits in the SRQ mask.
3. The front panel SRQ LED will turn on when the instrument generates an SRQ. The SRQ indicator will turn off when the SRQ condition is cleared.

Serial Poll Byte

4. If an error occurs, bit 5 (error) in the serial poll byte latches and remains so until the U1 word is read (paragraph 4.2.15). The U1 error status word defines the nature of the error.
5. The serial poll byte should be read to clear the SRQ line once the instrument has

- generated an SRQ. Pertinent bits in the serial poll byte will latch when the SRQ is generated. Bit 6 (SRQ) is cleared when the serial poll byte is read.
6. Even with SRQ disabled, the serial poll byte can be read to determine appropriate instrument conditions.

Programming Examples

```

10 DIM Err$(50)           ! Dimension string for error
20 REMOTE 722             ! Put 428 in remote
30 OUTPUT 722;"M32X"     ! Program for SRQ on error
40 OUTPUT 722;"F1X"     ! Program invalid command
50 S=SPOLL (722)         ! Serial poll the 428
60 IF NOT BIT(S,5) THEN 50 ! Wait for SRQ to occur
70 PRINT "B7 B6 B5 B4 B3 B2
   B1 B0"                ! Label the bit positions
80 FOR I=7 TO 0 STEP -1  ! Loop eight times
90 PRINT BIT(S,I);       ! Print the bit positions
100 NEXT I
110 PRINT
120 OUTPUT 722;"U1X"     ! Request U1 error word
130 ENTER 722;Err$
140 PRINT Err$
150 END

```

4.2.10 N — Suppression On/Off, Automatic Suppression

Purpose To turn suppression on or off and to perform automatic suppression

Format Nn

Parameters
N0 Turn suppression off
N1 Turn suppression on
N2 Perform automatic suppression

Default Upon power-up, or after receiving a DCL, SDC, or L2X command, the instrument returns to the power-on programmed default. The factory default is N0 (suppression off).

Description The N0 and N1 commands turn current suppression off or on, and they perform the same functions as the front panel ENABLE CURRENT SUPPRESS key. The N2 command performs automatic current suppression, after which current suppression will be left enabled. N2 performs the same operation as pressing SHIFT AUTO on the front panel.

Programming Notes

1. Suppression range and value are programmed with the S command (see paragraph 4.2.13).
2. Zero check should be turned off before attempting auto-suppression; otherwise a "Z CHECK ON" error will occur.
3. Error conditions for the N command are described in the U1 error status word (see paragraph 4.2.15).
4. The suppression value can be read from the instrument (paragraph 4.2.15).

Programming Examples

10	OUTPUT 722;"N1X"	! Turn on suppression
20	OUTPUT 722;"N0X"	! Turn off suppression

4.2.11 P — Filter On/Off

Purpose	To enable/disable the filter	
Format	Pn	
Parameters	P0 Filter off P1 Filter on	
Default	Upon power-up, or after receiving a DCL, SDC, or L2X command, the instrument returns to the programmed power-up conditions. Factory default is P0 (filter off).	
Description	The P command turns the internal 2-pole filter on or off. Thus, this command performs the same functions as the front panel ENABLE FILTER key.	
Programming Notes	<ol style="list-style-type: none"> 1. The filter rise time is controlled with the T command 2. With filter off (P0) and auto-filter on, default filtering is automatically applied when 10^8–10^{10}V/A gain is selected. See paragraph 4.2.20 for details on auto-filter. 	
Programming Examples	10 OUTPUT 722; "P1X"	! Turn filter on
	20 OUTPUT 722; "P0X"	! Turn filter off

4.2.12 R — Select Gain

Purpose	To program instrument gain	
Format	Rn	
Parameters	R0 10 ³ V/A gain R1 10 ³ V/A gain R2 10 ³ V/A gain R3 10 ³ V/A gain R4 10 ⁴ V/A gain R5 10 ⁵ V/A gain R6 10 ⁶ V/A gain R7 10 ⁷ V/A gain R8 10 ⁸ V/A gain R9 10 ⁹ V/A gain R10 10 ¹⁰ V/A gain	
Default	Upon power-up, or after receiving a DCL, SDC, or L2X command, the instrument returns to the programmed power-up default conditions. The factory default is R3 (10 ³ V/A gain).	
Description	The R command controls the overall instrument gain; thus this command and its options allow the same control functions as the front panel SETUP GAIN key.	
Programming Notes	<ol style="list-style-type: none">1. Specified gain values assume that X10 gain is turned off. All gain values must be increased by a factor of 10 when X10 gain is enabled (paragraph 4.2.17).2. The overall gain can be read from the instrument by using the U3 status word (paragraph 4.2.15).	
Programming Examples	10 OUTPUT 722;"R6X" 20 OUTPUT 722;"R1X"	! Program 10 ⁶ V/A gain ! Program 10 ³ V/A gain

4.2.13 S — Current Suppression Value and Range

Purpose	To control the current suppression value and range																						
Format	Svalue,range																						
Parameters	<p>Value: floating point number in amperes in the range of $-5E-3$ to $+5E-3$.</p> <p>Range: selects suppression range as follows:</p> <table border="0"> <tr> <td>S,0</td> <td>Enable auto-ranging</td> </tr> <tr> <td>Svalue,1</td> <td>± 5nA range, 1pA resolution</td> </tr> <tr> <td>Svalue,2</td> <td>± 50nA range, 10pA resolution</td> </tr> <tr> <td>Svalue,3</td> <td>± 500nA range, 100pA resolution</td> </tr> <tr> <td>Svalue,4</td> <td>$\pm 5$$\mu$A range, 1nA resolution</td> </tr> <tr> <td>Svalue,5</td> <td>$\pm 50$$\mu$A range, 10nA resolution</td> </tr> <tr> <td>Svalue,6</td> <td>$\pm 500$$\mu$A range, 100nA resolution</td> </tr> <tr> <td>Svalue,7</td> <td>± 5mA range, 1μA resolution</td> </tr> <tr> <td>S,8</td> <td>Invalid option (IDDCO error)</td> </tr> <tr> <td>S,9</td> <td>Invalid option (IDDCO error)</td> </tr> <tr> <td>S,10</td> <td>Disable auto-ranging</td> </tr> </table>	S,0	Enable auto-ranging	Svalue,1	± 5 nA range, 1pA resolution	Svalue,2	± 50 nA range, 10pA resolution	Svalue,3	± 500 nA range, 100pA resolution	Svalue,4	± 5 μ A range, 1nA resolution	Svalue,5	± 50 μ A range, 10nA resolution	Svalue,6	± 500 μ A range, 100nA resolution	Svalue,7	± 5 mA range, 1 μ A resolution	S,8	Invalid option (IDDCO error)	S,9	Invalid option (IDDCO error)	S,10	Disable auto-ranging
S,0	Enable auto-ranging																						
Svalue,1	± 5 nA range, 1pA resolution																						
Svalue,2	± 50 nA range, 10pA resolution																						
Svalue,3	± 500 nA range, 100pA resolution																						
Svalue,4	± 5 μ A range, 1nA resolution																						
Svalue,5	± 50 μ A range, 10nA resolution																						
Svalue,6	± 500 μ A range, 100nA resolution																						
Svalue,7	± 5 mA range, 1 μ A resolution																						
S,8	Invalid option (IDDCO error)																						
S,9	Invalid option (IDDCO error)																						
S,10	Disable auto-ranging																						
Default	Upon power-up, or after receiving a DCL, SDC, or L2X command, the instrument returns to the programmed power-up conditions. The factory default is S0,7 (0mA value, ± 5 mA range).																						
Description	<p>The S,0 and S,10 enable and disable suppression autoranging respectively. When auto-ranging is enabled (S,0), the range is determined by the value sent with subsequent S,0 commands. When auto-ranging is disabled (S,10), the suppression range remains at its last value.</p> <p>The commands Svalue,1 through Svalue,7 control the suppression value in a manner similar to the front panel SETUP CURRENT SUPPRESS key. The value parameter can be programmed in a variety of floating-point formats. For example, the following commands will all program a suppress current of 1mA on the 5mA range:</p> <pre>S1E-3,7X S.001,7X S10E-4,7X S.1E-2X</pre>																						
Programming Notes	<ol style="list-style-type: none"> 1. Programming a suppress value too large for the selected range will result in a conflict error. Similarly, a conflict error will result from programming too low a range for the selected value. A CONFLICT error message will be displayed on the front panel and will be flagged in the U1 error status word (paragraph 																						

- 4.2.15).
2. If the suppression value is too small for the selected range, the suppression value will automatically be set to zero.
 3. Suppression auto-ranging is available only over the IEEE-488 bus; it is not available when controlling the instrument over the front panel.
 4. Suppression must be turned on with the N command (paragraph 4.2.10) before the programmed suppress value can be used.
 5. The comma (,) must be included in the command string between the value and range parameters.
 6. The value or range parameter may be omitted from the command string if it is to be left unchanged, but you must include the comma in the command string. For example, S1E-6,X changes only the value, and S,6X changes only the range.
 7. Sending a value of 0 with auto-range (S0,0X) will cause the instrument to automatically go to the lowest range ($\pm 5\text{nA}$ range).

**Programming
Examples**

10	OUTPUT 722;"S1E-6,4X"	! 1 μ A value, $\pm 5\mu$ A range
20	OUTPUT 722;"S2.2E-9,1X"	! 2.2nA value, $\pm 5\text{nA}$ range
30	OUTPUT 722;"S,0X"	! Enable autorange
40	OUTPUT 722;"S1E-4,X"	! 100 μ A value, range unchanged
50	OUTPUT 722;"S,10X"	! Disable auto-range

4.2.14 T — Filter Rise Time

Purpose	To program the rise time of the filter	
Format	Tn	
Parameters	T0 10µsec rise time T1 30µsec rise time T2 100µsec rise time T3 300µsec rise time T4 1msec rise time T5 3msec rise time T6 10msec rise time T7 30msec rise time T8 100msec rise time T9 300msec rise time	
Default	Upon power-up, or after receiving a DCL, SDC, or L2X command, the instrument returns to the programmed power-up configuration. Factory default rise time is T0 (10µsec).	
Description	The T command performs the same functions as the front panel SETUP RISE TIME in that it allows you to program the filter rise time over the bus.	
Programming Notes	<ol style="list-style-type: none"> 1. The overall frequency response of the unit is determined both by the programmed rise time and the input amplifier response. See paragraph 3.8 for filter details. 2. The filter must be enabled with the P command (paragraph 4.2.11) before the programmed rise time will have an effect. 	
Programming Examples	10 OUTPUT 722;"T1X" 20 OUTPUT 722;"T3X" 30 OUTPUT 722;"T9X"	! Select 30µsec rise time ! Select 300µsec rise time ! Select 300msec rise time

4.2.15 U — Default and Alternate Output

Purpose To obtain instrument status, suppress value, bias value, gain, and model number and software revision level

Format Un

Parameters

- None Send suppress value
- U0 Send machine status word
- U1 Send error status word after talk command
- U2 Send voltage bias value
- U3 Send total gain
- U4 Send model number and software revision

Default Output Description The default output word from the Model 428 is the suppress value, which has the general format shown in Figure 4-2. To obtain the suppress value, address the unit to talk and input the word as a string without sending one of the U commands outlined below.

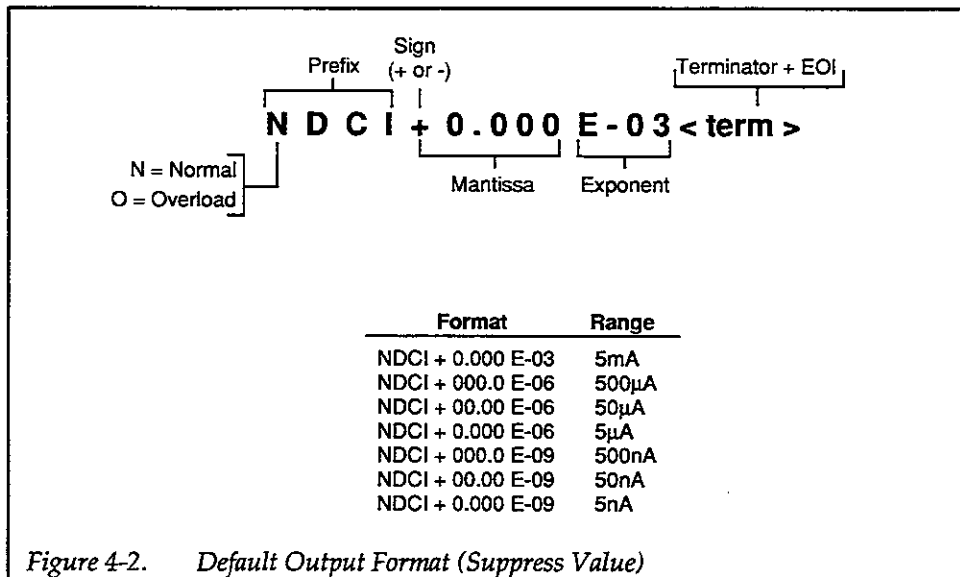

Alternate Output Description By sending the appropriate U command and then addressing the instrument to talk as with default output, you can obtain information on machine status, error conditions, and other data. The information is transmitted only once for each U command.

U0 — Machine Status Word

The format of the U0 machine status word is shown in Figure 4-3. After the 428 identifier, the letters correspond to the modes programmed by the respective de-

vice-dependent commands with the exception of the H, J, and S commands. The H (hit button) command field indicates the number of the last key pressed, and the J (self-test) command field returns the results of the self-tests run with the J command, as indicated in the figure. The S (suppress range) command field has two digits: the first digit indicates whether or not suppress auto range is enabled, and the second digit identifies the suppress range for both manual and auto ranging.

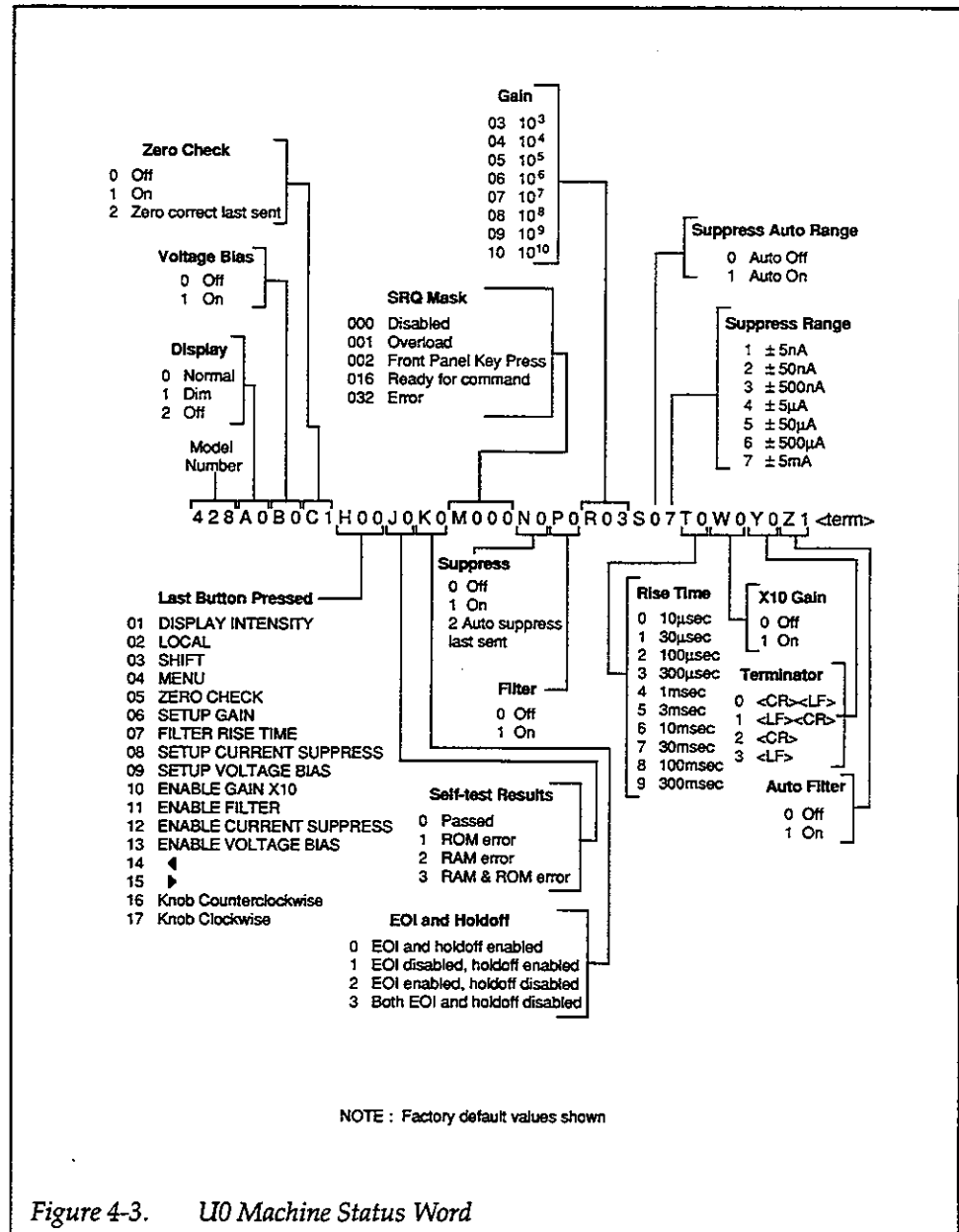

Figure 4-3. U0 Machine Status Word

U1 — Error Status Word

The U1 command allows access to Model 428 error conditions. The error status word (Figure 4-4) is actually a string of ASCII characters representing binary bit positions. Reading the U1 status clears any latched bits. An error or warning condi-

tion is flagged in the serial poll byte, and the instrument can be programmed to generate an SRQ when an error occurs (see paragraph 4.2.9).

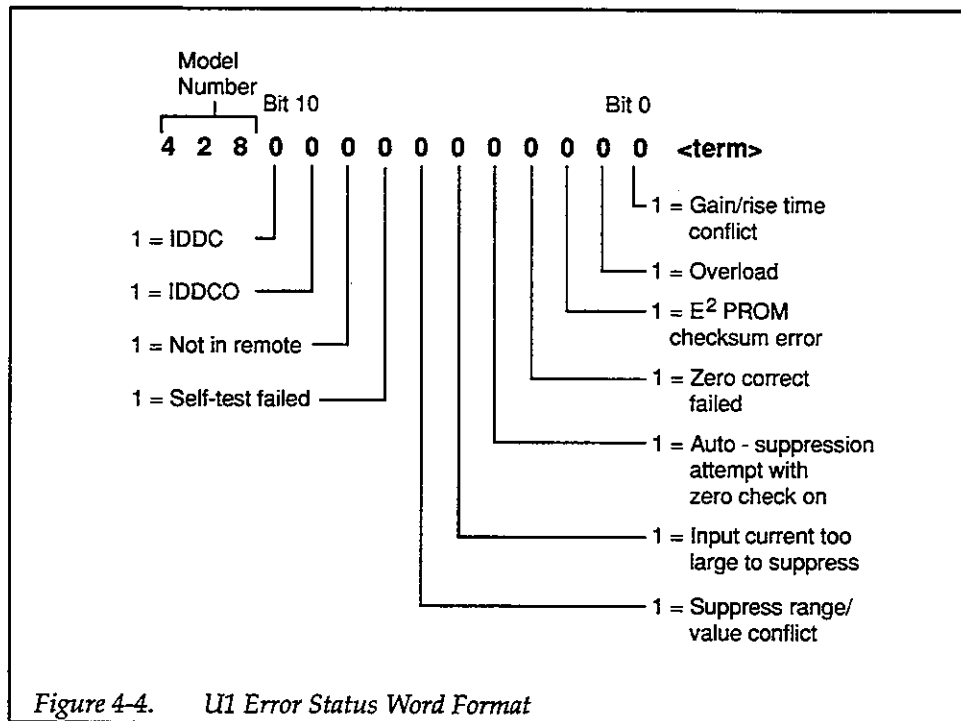

Figure 4-4. U1 Error Status Word Format

The various bits in the U1 error status word are set when the following conditions are present:

Gain/rise time conflict (bit 0): this bit will be set if the selected filter rise time is faster than the input amplifier and auto filter is on.

Overload condition (bit 1): an overload condition exists. Reduce the gain, the input current, or both.

E²PROM checksum error (bit 2): a checksum error was detected in the E²PROM on power-up. Same as front panel NO DFLTS error.

Zero correct failed (bit 3): the offset is too large to correct using zero correct. May indicate a hardware problem.

Auto-suppression requested (bit 4): zero check is on when attempting to auto-suppress. Turn zero check off before attempting to auto suppress.

Input current too large to suppress (bit 5): The current applied to the Model 428 input is too large to suppress.

Suppression range/value conflict (bit 6): The programmed suppress value is too large for the selected suppress range, or the programmed suppress range is too low for the selected suppress value.

Self-test failed (bit 7): a RAM or ROM error was detected during the self-test.

No remote (bit 8): the X character was received with the IEEE-488 bus REN line false.

IDDCO (bit 9): an Invalid Device-dependent Command Option was received.

IDDC (bit 10): an Invalid Device-dependent Command was received.

U2 — Voltage Bias Value

U2 returns the programmed voltage bias value with the format shown in Figure 4-5. The maximum bias voltage value is $\pm 5V$ with 2.5mV resolution. The bias voltage value is programmed with the V command, as described in paragraph 4.2.16.

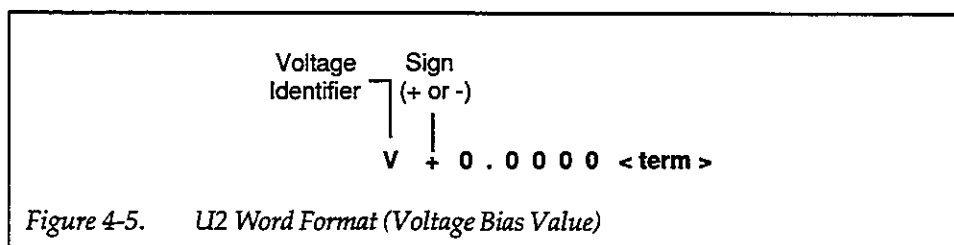

U3 — Total Gain

The U3 command returns the total gain of the instrument. This value includes the effects of both the setup gain (R) and the X10 gain (W). The format of the U3 word is shown in Figure 4-6.

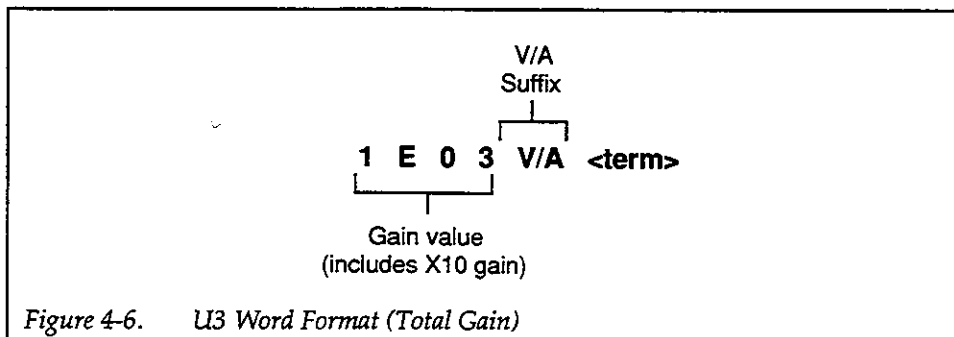

U4 — Model Number and Firmware Revision

The response to a U4 command is an 8-character ASCII string denoting the instrument model number (428) and firmware revision level, as shown in Figure 4-7.

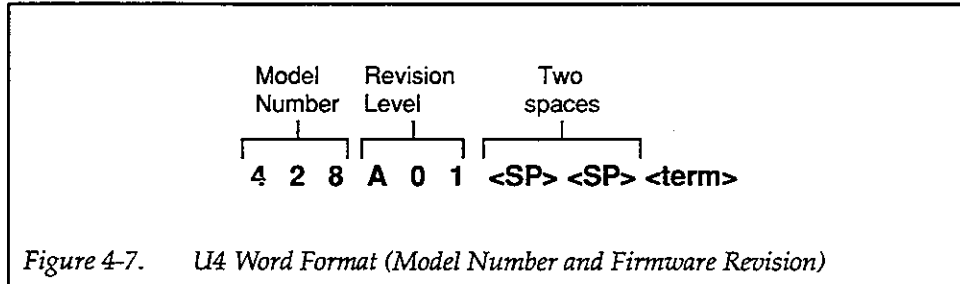

For example, a firmware revision level of A1 would be sent as follows:

428A01

The U4 word is sent with two trailing spaces plus the terminator and EOI (unless disabled with the K command).

Programming Notes

1. The terminator sequence is sent at the end of both default and alternate output strings. The terminator is programmed with the Y command (paragraph 4.2.19). Default terminator is <CR><LF>.
2. EOI will be asserted with the last character of the default or alternate output sequence if enabled with the K command (paragraph 4.2.7). Default is EOI enabled.
3. The R command field (gain) in the U0 status word will show only R03 for a selected gain of 10^3V/A even though R0 through R3 can be used to program a gain of 10^3V/A .

Programming Examples

```

10 DIM St$(50)           ! Dimension status string
20 REMOTE 722            ! Put 428 in remote
30 ENTER 722;St$        ! Request default output
40 PRINT St$            ! Print suppress value
50 FOR I= 0 TO 4        ! Loop for all status words.
60 OUTPUT 722;"U";I;"X" ! Program 428 with U command
70 ENTER 722;St$        ! Get U status
80 PRINT St$            ! Print U status
90 NEXT I               ! Loop back for next status
100 END

```

4.2.16 V — Voltage Bias Value

Purpose	To program the voltage bias value
Format	Vvalue
Parameter	$-5 \leq \text{value} \leq +5$, 0.0025 resolution
Default	Upon power-up, or after receiving a DCL, SDC, or L2X command, the instrument returns to the programmed power-up default value. The factory default is V0 (0V).
Description	<p>The V command programs the voltage bias value in a manner similar to the front panel SETUP VOLTAGE BIAS key. The allowable range for the bias value is -5V to $+5\text{V}$ with 2.5mV resolution. Value may be programmed with a variety of floating-point formats. For example, the following commands will all program a bias value of 1V:</p> <pre>VIX V1.0X V10E-1X V0.1E1X</pre>
Programming Notes	<ol style="list-style-type: none"> The bias voltage must be enabled with the B command before the programmed bias voltage will be applied to the INPUT jack. See paragraph 4.2.2. Zero check must be disabled to apply the programmed bias value to the input device (paragraph 4.2.3).
Programming Examples	<pre>10 OUTPUT 722;"V2.5X" ! Program +2.5V bias 20 OUTPUT 722;"V.5E1X" ! Program +5V bias 30 OUTPUT 722;"V5E-3X" ! Program +5mV bias 40 OUTPUT 722;"V-1E-2X" ! Program -10mV bias.</pre>

4.2.17 W — X10 Gain Off/On

Purpose	To enable and disable X10 gain
Format	Wn
Parameters	W0 Disable X10 gain W1 Enable X10 gain
Default	Upon power-up, or after receiving a DCL, SDC, or L2X command, the instrument returns to the programmed power-up default. The factory default is W0 (X10 gain off).
Description	The W command enables or disables X10 gain, and it performs the same operations as the front panel GAIN X10 key. When X10 gain is enabled (W1), the total gain of the instrument is increased by a factor of 10.
Programming Note	The total gain can be read from the instrument by using the U3 command (paragraph 4.2.15).
Programming Examples	10 OUTPUT 722; "W0X" ! Disable X10 gain 20 OUTPUT 722; "W1X" ! Enable X10 gain

4.2.18 X — Execute

Purpose	To direct the Model 428 to execute device-dependent commands received since last X.															
Format	<command>X															
Parameters	None															
Description	The execute command is implemented by sending an ASCII "X" over the bus. Its purpose is to direct the unit to execute other device-dependent commands such as R (gain) or T (rise time). Usually, the execute character is the last character in the command string (a number of commands may be grouped together into one string); however, there may be certain cases when it is desirable to send a command string at one time, and then send the execute character later on.															
Programming Notes	<ol style="list-style-type: none"> 1. Commands or command strings sent without the X character are not executed at that time, but they are stored in an internal command buffer for later execution (128 characters maximum). When the X character is finally transmitted, the stored commands are executed, assuming that all commands in the previous string were valid. 2. Commands are not necessarily executed in the order sent (see Table 4-2). To force a particular command sequence, include the X character after each command in the command string. 															
Programming Examples	<table border="0" style="width: 100%;"> <tr> <td style="width: 5%; vertical-align: top;">10</td> <td style="width: 50%; vertical-align: top;">OUTPUT 722;"P1X"</td> <td style="width: 45%; vertical-align: top;">! Execute single command.</td> </tr> <tr> <td style="vertical-align: top;">20</td> <td style="vertical-align: top;">OUTPUT 722;"P0N1X"</td> <td style="vertical-align: top;">! Execute multiple command string.</td> </tr> <tr> <td style="vertical-align: top;">30</td> <td style="vertical-align: top;">OUTPUT 722;"T0XW1X"</td> <td style="vertical-align: top;">! Force command sequence.</td> </tr> <tr> <td style="vertical-align: top;">40</td> <td style="vertical-align: top;">OUTPUT 722;"A1B1"</td> <td style="vertical-align: top;">! Send string without executing.</td> </tr> <tr> <td style="vertical-align: top;">50</td> <td style="vertical-align: top;">OUTPUT 722;"X"</td> <td style="vertical-align: top;">! Execute previous command string.</td> </tr> </table>	10	OUTPUT 722;"P1X"	! Execute single command.	20	OUTPUT 722;"P0N1X"	! Execute multiple command string.	30	OUTPUT 722;"T0XW1X"	! Force command sequence.	40	OUTPUT 722;"A1B1"	! Send string without executing.	50	OUTPUT 722;"X"	! Execute previous command string.
10	OUTPUT 722;"P1X"	! Execute single command.														
20	OUTPUT 722;"P0N1X"	! Execute multiple command string.														
30	OUTPUT 722;"T0XW1X"	! Force command sequence.														
40	OUTPUT 722;"A1B1"	! Send string without executing.														
50	OUTPUT 722;"X"	! Execute previous command string.														

4.2.19 Y — Terminator

Purpose To select the ASCII terminator sequence that marks the end of the default output and alternate output strings

Format Yn

Parameters
Y0 <CR><LF>
Y1 <LF><CR>
Y2 <CR>
Y3 <LF>

Default Upon power-up, or after receiving a DCL, SDC, or L2X command, the instrument returns to the programmed power-up defaults. Factory default is Y0 (<CR><LF>).

Description By using the Y command, you can program the number and type of terminator characters the instrument sends at the end of its default output and alternate output strings. Available terminator characters are the commonly used CR (carriage return, ASCII 13) and LF (line feed, ASCII 10) characters. These terminators are recognized by most controllers.

Programming Notes

1. Selecting the wrong terminator for the controller could cause the bus to hang when attempting to input strings from the instrument.
2. EOI will be asserted with the last terminator character if enabled with the K command (paragraph 4.2.7).

Programming Examples

10	OUTPUT 722; "Y1X"	! Terminate on <LF> <CR>.
20	OUTPUT 722; "Y0X"	! Restore default terminator.

4.2.20 Z — Auto-Filter On/Off

Purpose	To enable/disable auto-filter operation									
Format	Zn									
Parameters	Z0 Auto-filter off Z1 Auto-filter on									
Default	Upon power-up, or after receiving a DCL, SDC, or L2X command, the instrument returns to the programmed default value. Factory default is auto filter on (Z1).									
Description	<p>The Z command controls whether or not auto-filter is enabled when the filter is turned off (P0). When auto-filter is on (Z1), default rise times are automatically applied to 10^8, 10^9, and 10^{10}V/A gain settings only when the filter is disabled (P0). These default rise time values are as follows:</p> <table border="1" style="margin-left: 20px; border-collapse: collapse;"> <thead> <tr> <th style="text-align: left; border-bottom: 1px solid black;">Gain</th> <th style="text-align: left; border-bottom: 1px solid black;">Rise Time</th> </tr> </thead> <tbody> <tr> <td>10^8V/A</td> <td>10μsec</td> </tr> <tr> <td>10^9V/A</td> <td>30μsec</td> </tr> <tr> <td>10^{10}V/A</td> <td>100μsec</td> </tr> </tbody> </table> <p>When the filter is enabled (P1), auto-filter is disabled and the filter rise time can be set as desired with the T command.</p>		Gain	Rise Time	10^8 V/A	10 μ sec	10^9 V/A	30 μ sec	10^{10} V/A	100 μ sec
Gain	Rise Time									
10^8 V/A	10 μ sec									
10^9 V/A	30 μ sec									
10^{10} V/A	100 μ sec									
Programming Note	When auto-filter is on and filter is disabled, no filtering is applied with 10^3 to 10^7 V/A gain values.									
Programming Examples	OUTPUT 722; "Z1X"	! Enable auto-filter								
	OUTPUT 722; "Z0X"	! Disable auto-filter								

4.3 GENERAL BUS COMMANDS

General bus commands are those commands such as DCL that have the same general meaning regardless of the instrument. Commands supported by the Model 428 are listed in Table 4-3 which also lists HP BASIC 4.0 statements necessary to send each command. Note that commands requiring that a primary address be specified assume that the primary address is set to 22 (the default address of the Model 428).

4.3.1 REN (Remote Enable)

The remote enable command is sent to the Model 428 by the controller to set up the instrument for remote operation. Generally, the instrument should be placed in the remote mode before you attempt to program it over the bus. Simply setting REN true does not actually place the instrument in the remote state. Instead the instrument must be addressed to listen after setting REN true before it goes into remote.

Note that the instrument need not be in remote to be a talker.

Programming Example — This sequence is automatically performed by the controller when the following is typed into the keyboard.

REMOTE 722

After the RETURN key is pressed, the instrument is in the remote state, as indicated by the REM light. If not, check

to see that the instrument is set to the proper primary address (22), and check to see that the bus connections are properly made.

Note that all front panel controls except for LOCAL (and, of course, POWER) are inoperative while the instrument is in remote. You can restore normal front panel operation by pressing the LOCAL key (except when Local Lockout is in effect, in which case LOCAL will also be locked out).

4.3.2 IFC (Interface Clear)

The IFC command is sent by the controller to place the Model 428 in the local, talker and listener idle states. The unit responds to the IFC command by canceling front panel TALK or LSTN lights, if the instrument was previously placed in one of those states.

To send the IFC command, the controller need only set the IFC line true for a minimum of 100µsec.

Programming Example — Before demonstrating the IFC command, turn on the TALK indicator with the following statement:

ENTER 722;A\$

At this point, the TALK light should be on. The IFC command can be sent by entering the following statement into the computer:

ABORT 7

Table 4-3. General Bus Commands and Associated BASIC Statements

Command	HP BASIC 4.0 Statement	Effect on Model 428
REN	REMOTE 7	Goes into effect when next addressed to listen.
IFC	ABORT 7	Goes into talker and listener idle states.
LLO	LOCAL LOCKOUT 7	LOCAL key locked out.
GTL	LOCAL 722	Cancel remote, restore front panel operation.
DCL	CLEAR 7	Returns to power-up default conditions.
SDC	CLEAR 722	Returns to power-up default conditions.
SPE, SPD	SPOLL (722)	Serial poll 428.

After the RETURN key is pressed, the TALK indicator turns off, indicating that the instrument has gone into the talker idle state.

4.3.3 LLO (Local Lockout)

The LLO command is used to prevent local operation of the instrument. After the unit receives LLO, all its front panel controls except POWER are inoperative.

Programming Example — The LLO command is sent by entering the following statements:

```
REMOTE 722
LOCAL LOCKOUT 7
```

After the second statement is executed, the instrument's front panel controls are locked out, including the LOCAL key.

To restore front panel operation after asserting LLO, send GTL, as discussed in the following paragraph.

4.3.4 GTL (Go To Local) and Local

The GTL command is used to take the instrument out of the remote state and restore operation of the front panel keys. GTL will also cancel LLO if the instrument is currently in the local lockout state.

Programming Example — Place the instrument in the remote state with the following statement:

```
REMOTE 722
```

Now send GTL with the following statement:

```
LOCAL 722
```

Note that the instrument goes into the local state, and that operation of the front panel keys has now been restored.

4.3.5 DCL (Device Clear)

The DCL command may be used to clear the Model 428 and return it to its power-up default conditions (see Table 4-4). Note that the DCL command is not an addressed command, so all instruments designed to implement DCL will do so simultaneously. When the Model 428 receives a DCL command, it returns to the power-up default conditions. DCL does not affect the programmed primary address.

Programming Example — Place the unit in an operating mode that is not a power-up default condition. Now enter the following statement from the controller keyboard:

```
CLEAR 7
```

When the RETURN key is pressed, the instrument returns to the power-up default conditions.

4.3.6 SDC (Selective Device Clear)

The SDC command is an addressed command that performs exactly the same function as the DCL command. However, since each device must be individually addressed, the SDC command provides a method to clear only selected instruments instead of clearing all instruments simultaneously, as is the case with DCL. When the Model 428 receives the SDC command, it returns to the power-up default conditions (Table 4-4). Like DCL, SDC does not affect the programmed primary address.

Programming Example — Place the unit in an operating mode that is not a power-up default condition. Now enter the following statement from the controller keyboard:

```
CLEAR 722
```

This command sends the following IEEE-488 commands: UNT UNL LISTEN 22 SDC. When the statement is executed, the instrument executes its power-up sequence and returns to the power-up default configuration.

4.3.7 SPE, SPD (Serial Polling)

The serial polling sequence is used to obtain the Model 428 serial poll byte. The serial poll byte contains important information about internal functions, as described in paragraph 4.2.9. Generally, the serial polling sequence is

used by the controller to determine which of several instruments has requested service with the SRQ line. Also, the serial polling sequence may be performed at any time to obtain the serial poll byte from the Model 428.

Programming Example — The SPOLL statement automatically performs the serial poll sequence. To demonstrate serial polling, enter in the following program lines into the computer:

```
10 S=SPOLL (722)
20 PRINT "SPOLL BYTE=";S
30 END
```

Run the program and note that the decimal value of the serial poll byte is displayed on the controller CRT.

Table 4-4. Factory Default Conditions

Mode	Default State
DISPLAY INTENSITY	Normal (A0)
CURRENT SUPPRESS	0.000mA, off (S0, 7N0)
GAIN	10 ³ V/A (R3)
GAIN X10	Off (W0)
FILTER	Off (P0)
FILTER RISE TIME	10μsec (T0)
VOLTAGE BIAS	0.000V, off (V0, B0)
ZERO CHECK	On (C1)
AUTO FILTER	On (Z1)
SRQ	Disabled (M0)
EOI	EOI and holdoff enabled (K0)
Terminator	<CR><LF> (Y0)
IEEE-488 Address*	22

*Primary address is not affected by DCL or SDC

4.4 PRIMARY ADDRESS PROGRAMMING

The Model 428 must receive a listen command before responding to addressed commands. Similarly, the unit must receive a talk command before transmitting data. The Model 428 is shipped from the factory with a programmed primary address of 22.

The primary address may be set to any value between 0 and 30 as long as address conflicts with other instruments are avoided. Note that controllers also use a primary address, so do not use the same address as the controller.

Most frequently, controller addresses are 0 or 21, but you should consult the controller's instruction manual for details. Whatever primary address you choose, you must make certain that it corresponds with the value specified as part of the controller's programming language.

To check the present primary address or to change to a new one, perform the following procedure:

1. Press the MENU button twice to display the address. For example, if the instrument is set to the factory default primary address of 22, the following message will be displayed:

IEEE 22

2. To retain the current address, press SHIFT EXIT to exit from the menu. The instrument will briefly display the following:

NO CHANGE

3. To change the primary address, use the knob or cursor keys, then press MENU to complete programming the new address. This action stores the new address in memory so that the instrument powers up with that address. If you change the primary address, the unit will briefly display the following message:

CHANGED

NOTE

Each device on the bus must have a unique primary address. Failure to observe this precaution will probably result in improper bus operation.

4.5 FRONT PANEL ASPECTS OF IEEE-488 OPERATION

The following paragraphs discuss aspects of the front panel that are part of IEEE-488 operation, including messages, status indicators, and the LOCAL key.

4.5.1 Front Panel Messages

The Model 428 has a number of front panel messages. These messages, which are listed in Table 4-5, inform you of certain conditions that occur when programming the instrument.

Table 4-5. Front Panel Messages

Message	Description
CONFLICT	Conflict between suppression range and value
CORECT ERR	Input offset too large for zero correct
CORRECTING SUPRESSING	Unit performing zero correct Unit performing automatic suppression
IDDC	Invalid Device-dependent Command
IDDCO	Invalid Device-dependent Command Option
NO REMOTE OUT OF RNG	X received while not in remote Input current too large for auto suppress
OVERLOAD	Input or output overload (message flashes while overload exists)
Z CHECK ON	Auto suppress attempt with zero check on

The following paragraphs describe only those front panel messages associated exclusively with IEEE-488 programming. Note that the instrument may be programmed to generate an SRQ, and U command status words can be checked for specific error conditions if any of these errors occur. See paragraphs 4.2.9 and 4.2.15.

IDDC (Invalid Device-dependent Command) Error

An IDDC error occurs when the unit receives an invalid device-dependent command over the bus. For example, the command string F1X includes an invalid command because "F" is not part of the instrument's programming language. When an invalid command is received, the instrument briefly displays the IDDC error message.

NOTE

When an IDDC error is detected in a command string, all commands in the string, up to and including the next X, are ignored.

To correct error conditions, send only valid commands. Refer to paragraph 4.2 for device-dependent command programming details. Note that an IDDC error is also flagged in the U1 error status word, as discussed in paragraph 4.2.15.

Programming Example — To demonstrate an IDDC error, use the following statements:

```
REMOTE 722
OUTPUT 722;"F1X""
```

The IDDC error message is briefly displayed when the second statement above is executed.

IDDCO (Invalid Device-dependent Command Option) Error

Sending the instrument a valid command with an invalid option results in the IDDCO error message being displayed.

For example, the command W2X has an invalid option (2) that is not part of the instrument's programming language. Thus, although the command W is valid, the option is not, and the IDDCO error results.

NOTE

When an IDDCO error is detected in a command string, all commands in the string, up to and including the next X, are ignored.

To correct this error condition, use only valid command options, as discussed in paragraph 4.2. Note that an IDDCO error is also flagged in the U1 error status word, as discussed in paragraph 4.2.15.

Programming Example — Demonstrate an IDDCO error with the following statements:

```
REMOTE 722
OUTPUT 722;"W2X"
```

Note that the IDDCO error message is briefly displayed when the second statement above is executed.

No Remote Error

A no remote error occurs if the instrument receives an "X" while the bus REN line is false. The NO REMOTE error message is displayed under these conditions. This error is caused by failing to set the REN line true before addressing the Model 428 to listen. (The HP9000 default is to set REN true.) The statement "REMOTE 7" sets the

REN line true; the statement "REMOTE 722" sets the REN line true and addresses unit 22 to listen.

Programming Example — To demonstrate the NO REMOTE error message, type in the following lines:

```
LOCAL 7  
OUTPUT 722;"W0X"
```

Note that the NO REMOTE error message is briefly displayed when the second statement is executed.

4.5.2 IEEE-488 Status Indicators

The REM (remote), TALK, LSTN (listen), and SRQ (service request) indicators show the present IEEE-488 status of the instrument. Each of these indicators is briefly described below.

REM — As the name implies, this indicator shows when the instrument is in the remote state. Note that REM does not necessarily indicate the state of the REN line, as the instrument must be addressed to listen with REN true before the REM indicator turns on. When the instrument is in remote, all front panel keys except for the LOCAL key are locked out. When REM is turned off, the instrument is in the local state, and front panel operation is restored.

TALK — This indicator is on when the instrument is in the talker active state. The unit is placed in this state by addressing it to talk with the correct MTA (My Talk Address) command. TALK is off when the unit is in the talker idle state. The instrument is placed in the talker idle state by sending it an UNT (Untalk) command, addressing it to listen, or with the IFC (Interface Clear) command.

LSTN — This indicator is on when the Model 428 is in the listener active state, which is activated by addressing the instrument to listen with the correct MLA (My Listen Address) command. LSTN is off when the unit is in the listener idle state. The unit can be placed in the listener idle state by sending UNL (Unlisten), addressing it to talk, or by sending IFC (Interface Clear) over the bus.

SRQ — This indicator shows that the Model 428 has generated a service request over the bus. Conditions that can

generate a service request include: overload, front panel key press, ready for a command, and a number of error conditions such as IDDC and IDDCO. Refer to paragraph 4.2.9 for additional SRQ information.

4.5.3 LOCAL Key

The LOCAL key cancels the remote state and restores local operation of the instrument.

Since all front panel keys except LOCAL are locked out when the instrument is in remote, this key provides a convenient method of restoring front panel operation. Pressing LOCAL also turns off the REM indicator, and returns the display to normal if a message was displayed with the D command. (See paragraph 4.2.4.)

Note that the LOCAL key is also inoperative if the LLO (Local Lockout) command is in effect.

4.6 BUS CONNECTIONS

The following paragraphs discuss bus connections, recommended connecting cables, as well as contact designations.

4.6.1 Recommended Cables

In order to minimize the possibility of RFI, use only shielded IEEE-488 cables such as the Keithley Model 7007.

4.6.2 Typical Connections

A typical connecting scheme for a multiple-instrument setup is shown in Figure 4-8. To make connections to the Model 428, simply line up the mating connector with the IEEE-488 connector on the rear panel, then seat the connector firmly. Tighten the screws securely, then make sure the other end of the cable is connected to the controller or other device as the case may be. Theoretically, up to 14 (see bus limitations) connectors could be stacked on one instrument, but it is recommended that you stack no more than three connectors on any one instrument to avoid possible mechanical damage.

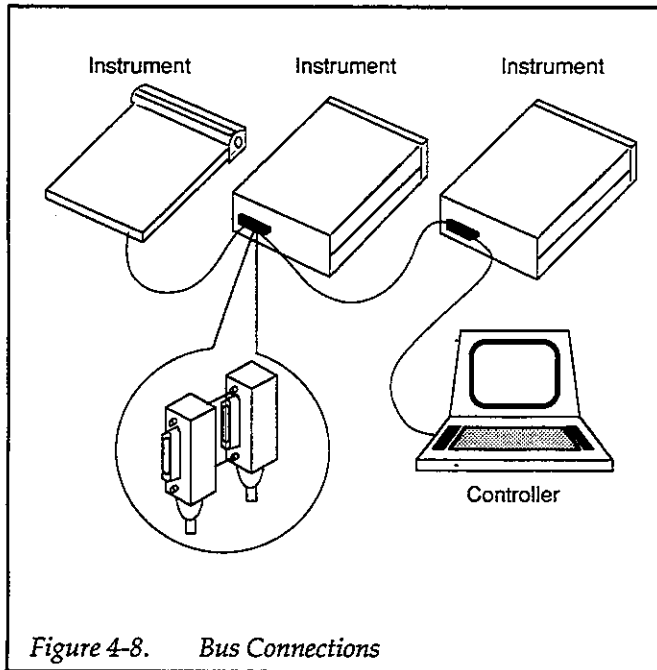

Figure 4-8. Bus Connections

4.6.3 Bus Limitations

The IEEE-488 bus is limited to a maximum of 15 devices including the controller. The maximum cable length is 20 meters, or two meters times the number of devices connected, whichever is less. Failure to observe these limits may result in improper bus operation.

4.6.4 Contact Designations

Table 4-6 lists contact assignments for the IEEE-488 bus.

Table 4-6. IEEE-488 Contact Assignments

Contact Number	IEEE-488 Designation	Type
1	DIO1	Data
2	DIO2	Data
3	DIO3	Data
4	DIO4	Data
5	EOI (24)*	Management
6	DAV	Handshake
7	NRFD	Handshake
8	NDAC	Handshake
9	IFC	Management
10	SRQ	Management
11	ATN	Management
12	Shield	Ground
13	DIO5	Data
14	DIO6	Data
15	DIO7	Data
16	DIO8	Data
17	REN (24)*	Management
18	Gnd. (6)*	Ground
19	Gnd. (7)*	Ground
20	Gnd. (8)*	Ground
21	Gnd. (9)*	Ground
22	Gnd. (10)*	Ground
23	Gnd. (11)*	Ground
24	Logic Gnd.	Ground

*Numbers in parenthesis refer to signal ground return of references contact number

SECTION 5

Performance Verification

5.1 INTRODUCTION

The procedure outlined in this section may be used to verify that the instrument is operating within the limits stated in the specifications at the front of this manual. Performance verification may be performed when the instrument is first received to ensure that no damage or misadjustment has occurred during shipment. Verification of performance specifications should be done once per year to detect incorrect 428 operation caused from instrument abuse or aging components.

WARNING

The information in this section is intended only for qualified personnel who are familiar with the procedures for using electronics test equipment. Do not attempt to perform these procedures unless you are qualified to do so.

NOTE

If the instrument is still under warranty, and its performance is not within specified limits, contact your Keithley representative or the factory to determine the correct course of action.

This section is arranged as follows:

- 5.2 **Environmental Conditions:** States the proper temperature and humidity limits for the tests.
- 5.3 **Initial Conditions:** Details the correct warm-up procedure for the tests.
- 5.4 **Recommended Test Equipment:** Summarizes the test equipment required to perform the verification procedures.

- 5.5 **Verification Procedures:** Details the procedure for checking gain accuracy, voltage bias and suppression function checks, and input bias current and output offset voltage measurements.

5.2 ENVIRONMENTAL CONDITIONS

All measurements should be made at 18°-28°C (65°-82°F) and at less than 70% relative humidity unless otherwise indicated.

5.3 INITIAL CONDITIONS

The Model 428 and the test equipment should be turned on and allowed to warm up for at least one hour before beginning the verification procedures. If any of the equipment has been subjected to temperature or humidity extremes, additional time should be allowed for temperatures to stabilize. Typically, it takes one additional hour to stabilize a unit that is 10°C (18°F) outside the specified temperature range.

5.4 RECOMMENDED TEST EQUIPMENT

Table 5-1 lists recommended test equipment for performing the verification procedures. Alternate equipment may be used as long as the equipment has specifications at least as good as those listed in the table.

Table 5-2 summarizes recommended cables and adapters.

NOTE

Use only low-noise coaxial cable such as the recommended Model 4801 for Model 428 input connections.

Table 5-1. Recommended Test Equipment

Manufacturer	Model	Description	Specifications
Keithley	199	DMM	300mV DC range, $\pm 0.012\%$ 3V DC range, $\pm 0.007\%$ 30V DC range, $\pm 0.009\%$
Keithley	263	Calibrator/Source	200pA range, $\pm 0.25\%$ 2nA, 20nA ranges, $\pm 0.065\%$ 200nA range, $\pm 0.035\%$ 2 μ A, 20 μ A, 200 μ A, 2mA, $\pm 0.025\%$

Table 5-2. Recommended Cables and Adapters

Manufacturer	Description	Application
Keithley	4801 Low-noise coax cable	Calibrator to 428 input
Keithley	7051 50 Ω BNC coax cable*	428 output to DMM via adapter
Keithley	6147 2-lug triax to BNC	Adapt coax cable to calibrator
Pomona	1269 BNC to dual banana	Adapt coax cable to DMM

*A second Model 4801 cable may be substituted for the Model 7051

5.5 VERIFICATION PROCEDURES

5.5.1 Gain Accuracy

Follow the steps below to verify the overall gain and X10 gain accuracy of the Model 428.

NOTE

The verification limits given in the procedures do not include test equipment accuracy.

Gain Accuracy Test Connections

Figure 5-1 shows the test connections for determining gain accuracy. With the power off, the current calibrator should be connected to the Model 428 INPUT connector using a Model 4801 coaxial cable and Model 6147 triax-to-BNC adapter. Connect the Model 428 INVERTING OUTPUT connector to the DMM using a Model 4801 or 7051 cable and the BNC-to-dual banana adapter. Be sure to connect BNC shell to DMM LO, or the measured voltage polarity will be reversed from that indicated in the procedures.

Gain Accuracy Tests

1. Turn on the test equipment and the Model 428 and allow them to warm up for at least one hour before beginning the tests.
2. Set up the Model 199 DMM as follows:

Function: DCV
Range: 3V
Resolution: 5-1/2 digits
Zero: off

3. Set up the Model 263 Calibrator as follows:

Function: Amps
Guard: off
Range: 2mA
Operate: standby

4. Set up the Model 428 as follows:

Zero check: on
Gain: 10³V/A
Gain X10: off
Filter: off
Current suppress: off
Voltage bias: off

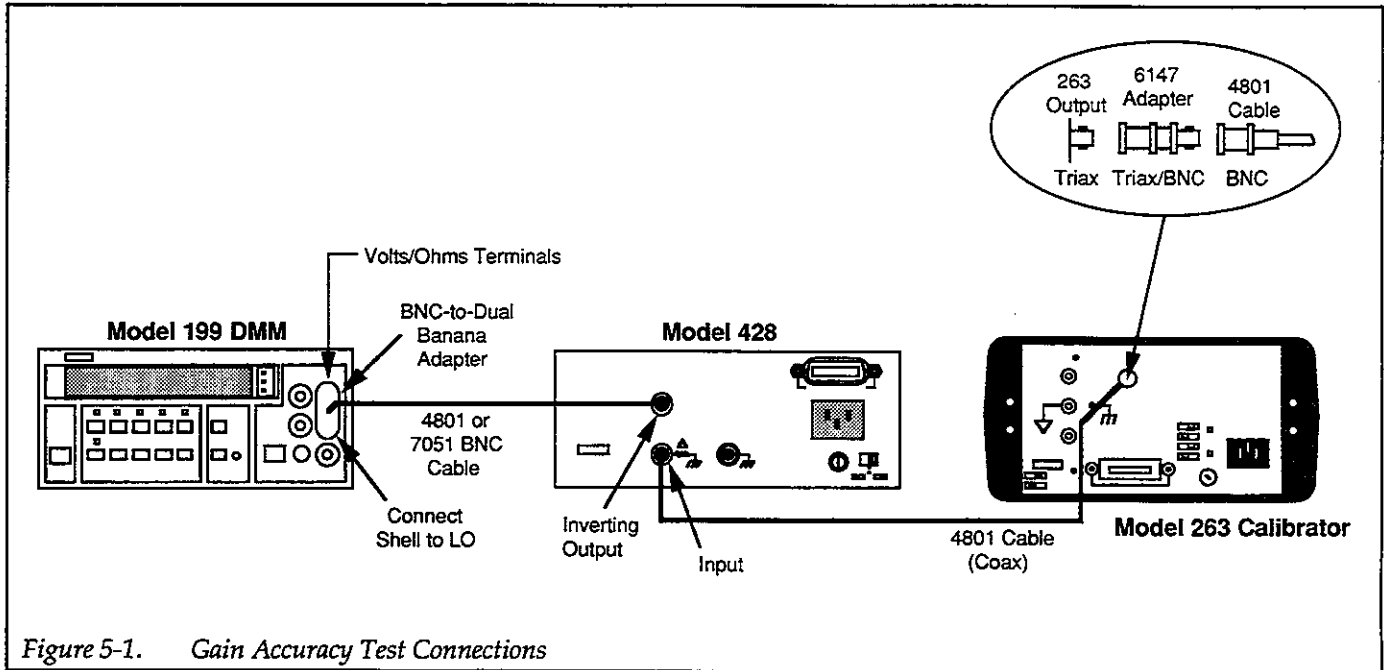

Figure 5-1. Gain Accuracy Test Connections

Table 5-3. Gain Accuracy Test Procedure

Step	428 Gain (V/A)	263 Range	263 Output	DMM Reading Range
1	10^3	2mA	1.9000mA	-1.90975 to -1.89025V
2	10^4	200 μ A	190.00 μ A	-1.90709 to -1.89291V
3	10^5	20 μ A	19.000 μ A	-1.90709 to -1.89291V
4	10^6	2 μ A	1.9000 μ A	-1.90766 to -1.89234V
5	10^7	200nA	190.00nA	-1.91072 to -1.88928V
6	10^8	20nA	19.000nA	-1.928 to -1.872V
7	10^9	2nA	1.9000nA	-1.9505 to -1.8495V
8	10^{10}	200pA	190.00pA	-1.9635 to -1.8365V

5. Press SHIFT CORRECT on the Model 428 to zero correct the instrument.
6. Disable zero check on the Model 428, then allow the reading to settle.
7. Enable zero on the DMM, and leave zero enabled for the remainder of the test.
8. Program the current calibrator for an output current of 1.9000mA, then place the calibrator in operate.
9. Verify that the DMM reading is in the range of -1.90975 to -1.89025V, as summarized in Table 5-3.
10. Repeat steps 7 through 9 for each gain setting listed in Table 5-3. Be sure the calibrator range and output current are set appropriately for each corresponding gain setting.
11. Repeat steps 7 through 10 for negative currents. Output voltages will be positive with negative input currents, but the magnitudes should be the same.
12. Enable zero check after the test is complete before disconnecting the input cable.

X10 Gain Accuracy

1. Turn on the test equipment and the Model 428, and allow them to warm up for at least one hour before beginning the tests.
2. Set up the Model 199 DMM as follows:

Function: DCV
 Range: 30V
 Resolution: 5-1/2 digits
 Zero: off

3. Set up the Model 263 Calibrator as follows:

Function: Amps
 Guard: off
 Range: 2mA
 Output current: 0.5000mA
 Operate: standby

4. Set up the Model 428 as follows:

Zero check: on
 Gain: 10^3V/A
 Gain X10: on
 Filter: off
 Current suppress: off
 Voltage bias: off

5. Press SHIFT CORRECT on the Model 428 to zero correct the instrument.
6. Disable zero check on the Model 428, and allow the DMM reading to settle.
7. Enable DMM zero.
8. Place the Model 263 Calibrator in operate.
9. Verify that the DMM reading is in the range of -5.0445 to -4.9555V .
10. Enable zero check, and disable DMM zero. Put the calibrator in standby, and set the calibrator output to -0.5000mA .
11. Repeat steps 6 through 10. The DMM reading should be within the range of $+4.9555$ to $+5.0445\text{V}$.

12. Enable zero check when the test is complete before disconnecting cables.

5.5.2 Voltage Bias Accuracy Check

Perform the steps below to verify that the voltage bias source is operating properly. These measurements can be made at a temperature between 0° and 50°C .

1. With the power off, connect the DMM to the Model 428 INPUT connector, as shown in Figure 5-2.
2. Turn on the DMM and the Model 428, and allow them to warm up for one hour.
3. Set up the DMM as follows:

Function: DCV
 Range: auto
 Resolution: 5-1/2 digits
 Zero: off

4. Set up the Model 428 as follows:

Gain: 10^3V/A
 Gain X10: off
 Current suppress: off
 Voltage bias: on
 Zero check: off

5. Press SETUP VOLTAGE BIAS, and program a bias voltage of $+5.000\text{V}$.
6. Verify the DMM reading is between 4.92 and 5.08V .
7. Set the Model 428 voltage bias to -5.000V .
8. Verify that the DMM reading is between -5.08 and -4.92V .
9. Enable zero check when the test is complete before disconnecting cables.

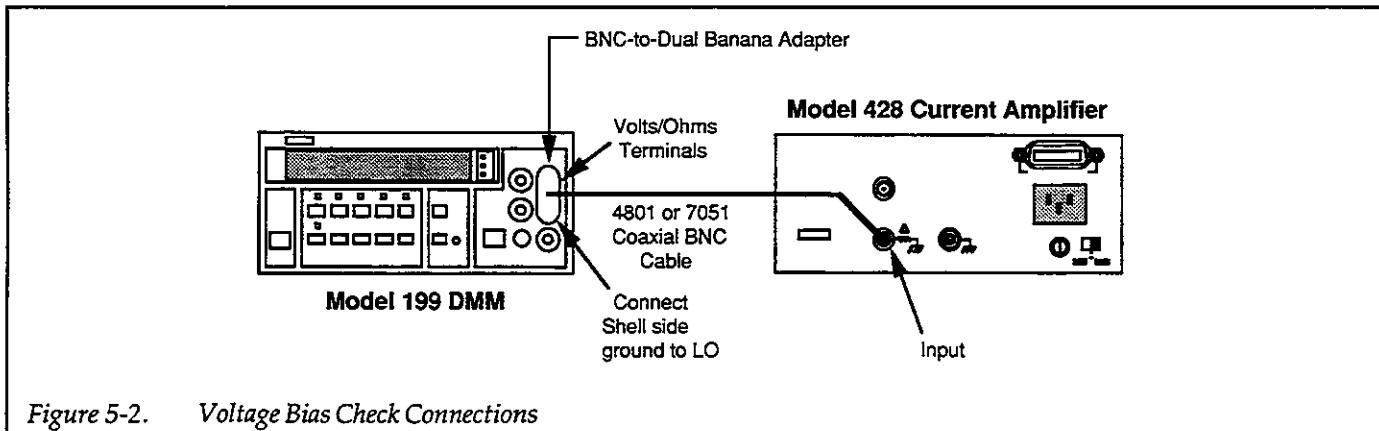

Figure 5-2. Voltage Bias Check Connections

5.5.3 Current Suppression Accuracy Check

Use the procedure below to verify that current suppression is functioning properly. These measurements can be made at 0-50°C.

1. With the power off, connect the current calibrator to the Model 428 (see Figure 5-3).
2. Turn on the calibrator and the Model 428, and allow them to warm up for one hour.
3. Set up the Model 263 Calibrator as follows:

Function: amps
Range: 2mA
Guard: off
Output current: +1.9000mA

4. Set up the Model 428 as follows:

Gain: 10³V/A
X10 gain: off
Filter: off

Voltage bias: off
Suppress: off
Suppress range: ±5mA
Zero check: off

5. Put the calibrator in operate.
6. Press SHIFT AUTO to perform auto suppression.
7. After auto suppression is completed, verify that the suppress value is between -1.921 and -1.879mA (press SETUP CURRENT SUPPRESS to view the suppress value).
8. Repeat steps 6 through 8 for the currents listed in Table 5-4. For each of these values, first disable suppress then set the gain and suppress range to the indicated setting before performing the procedure. The displayed suppress value should be within the limits shown in Table 5-4.
9. Repeat steps 6-8 for negative input currents of the same magnitudes listed in Table 5-4. Displayed suppress values will be positive with magnitudes as shown.
10. Enable zero check when the test is complete before disconnecting cables.

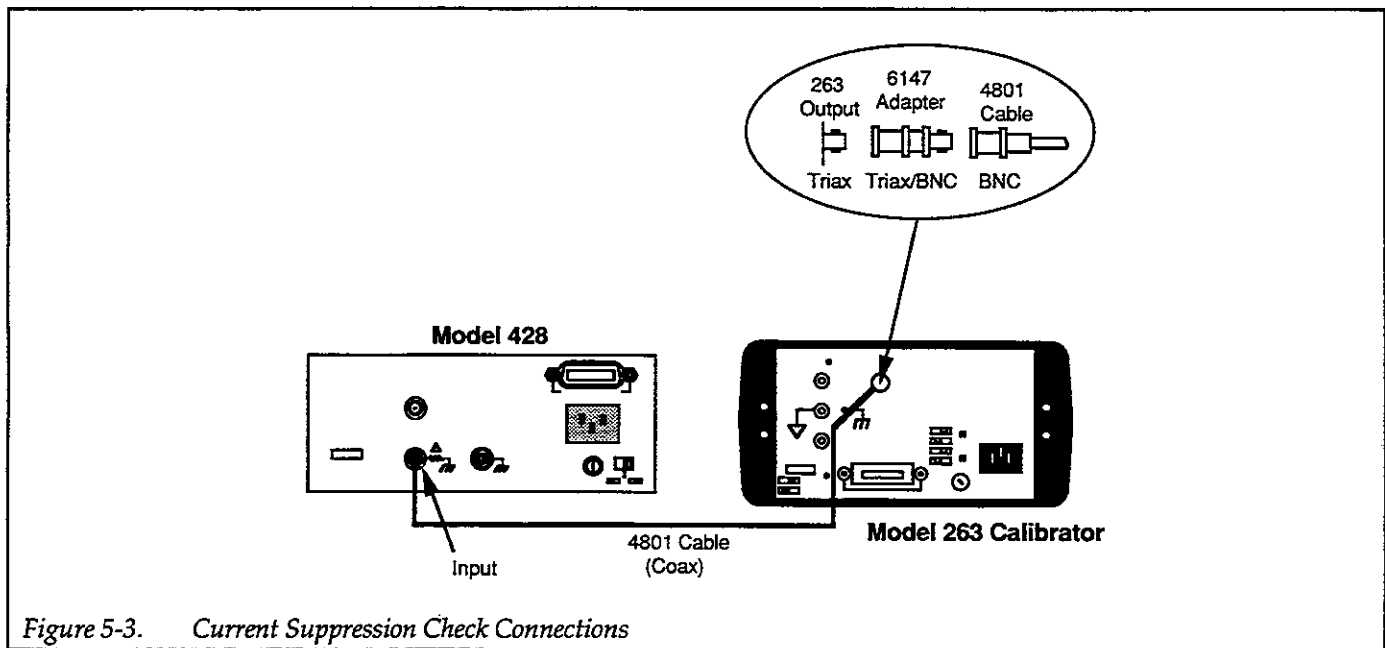

Figure 5-3. Current Suppression Check Connections

Table 5-4. Suppression Verification

Model 428 Gain (V/A)	Suppress Range	263 Range	263 Output Current	428 Suppress Reading Range
10 ³	±5mA	2mA	1.9000mA	-1.921 to -1.879mA
10 ⁴	±500µA	200µA	190.00µA	-192.1 to -187.9µA
10 ⁵	±50µA	20µA	19.000µA	-19.21 to -18.79µA
10 ⁶	±5µA	2µA	1.9000µA	-1.923 to -1.877µA
10 ⁷	±500nA	200nA	190.00nA	-192.5 to -187.5nA
10 ⁸	±50nA	20nA	19.000nA	-19.40 to -18.60nA
10 ⁹	±5nA	2nA	1.9000nA	-1.967 to -1.833nA

SECTION 6

Theory of Operation

6.1 INTRODUCTION

Section 6 contains detailed electronics operating theory for the various circuits within the Model 428, and it contains the following information:

6.2 Block Diagram: Gives an overview of instrument circuits in block diagram form.

6.3 Analog Circuits: Covers in detail the various analog circuits, including the input amplifier, differential amplifier, filter, voltage bias, and suppress circuits.

6.4 Digital Circuits: Describes the digital circuits, including the microprocessor, display and keyboard circuits, and the IEEE-488 interface.

6.5 Power Supplies: Covers the $\pm 15V$, $+6.5V$ and $+5V$ power supplies.

6.2 BLOCK DIAGRAM

Figure 6-1 shows the overall block diagram of the instrument. The purpose of each major block is as follows:

I-V converter (input amplifier): provides the current-to-voltage conversion function of the Model 428. The I-V converter is designed with low input bias current and low input offset voltage drift for excellent low-noise, low-current performance.

Differential amplifier: provides switchable X1 and X10 gain and also subtracts the voltage bias offset from the I-V converter output signal when voltage bias is enabled.

Low-pass filter: gives selectable rise-time filtering with $-12dB$ per octave roll-off.

Current suppression source: generates the suppression current applied to the input of the I-V converter when enabled.

Voltage bias source: generates the $\pm 5V$ programmable bias voltage. Note that the bias voltage is applied to the noninverting input of the input amplifier.

Command Registers: hold the digital command information that controls the current suppress and voltage bias sources, and relay and filter settings.

Microprocessor: controls the current suppress and voltage bias circuits, the I-V converter gain, the differential amplifier, the low-pass filter, as well as the front panel and the IEEE-488 circuits (428-PROG).

Front panel keyboard and display: provides the I/O interface via the front panel.

IEEE-488 interface (Model 428-PROG only): includes the circuits necessary to interface the instrument to the IEEE-488 bus.

Power supplies: convert the AC line input voltage to stable DC voltages for all internal circuits.

6.3 ANALOG CIRCUITS

The following paragraphs discuss the various analog circuits, including the input amplifier, differential amplifier, filter, as well as the current suppress and voltage bias sources.

6.3.1 Analog Block Diagram

Figure 6-2 shows a detailed block diagram of the analog circuits, and Figure 6-3 shows a simplified signal-flow diagram. Key analog sections are discussed in detail in the following paragraphs.

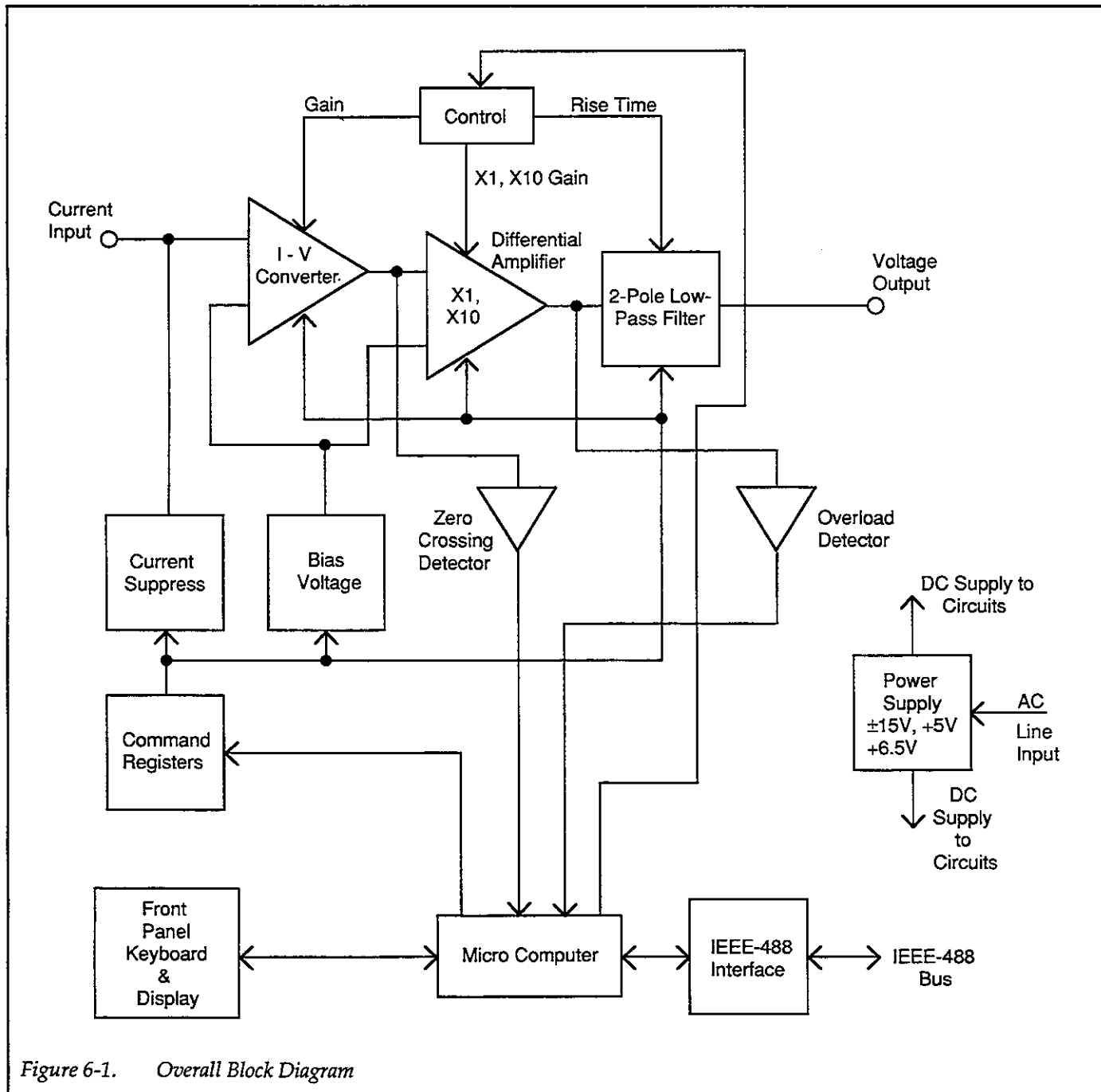

Figure 6-1. Overall Block Diagram

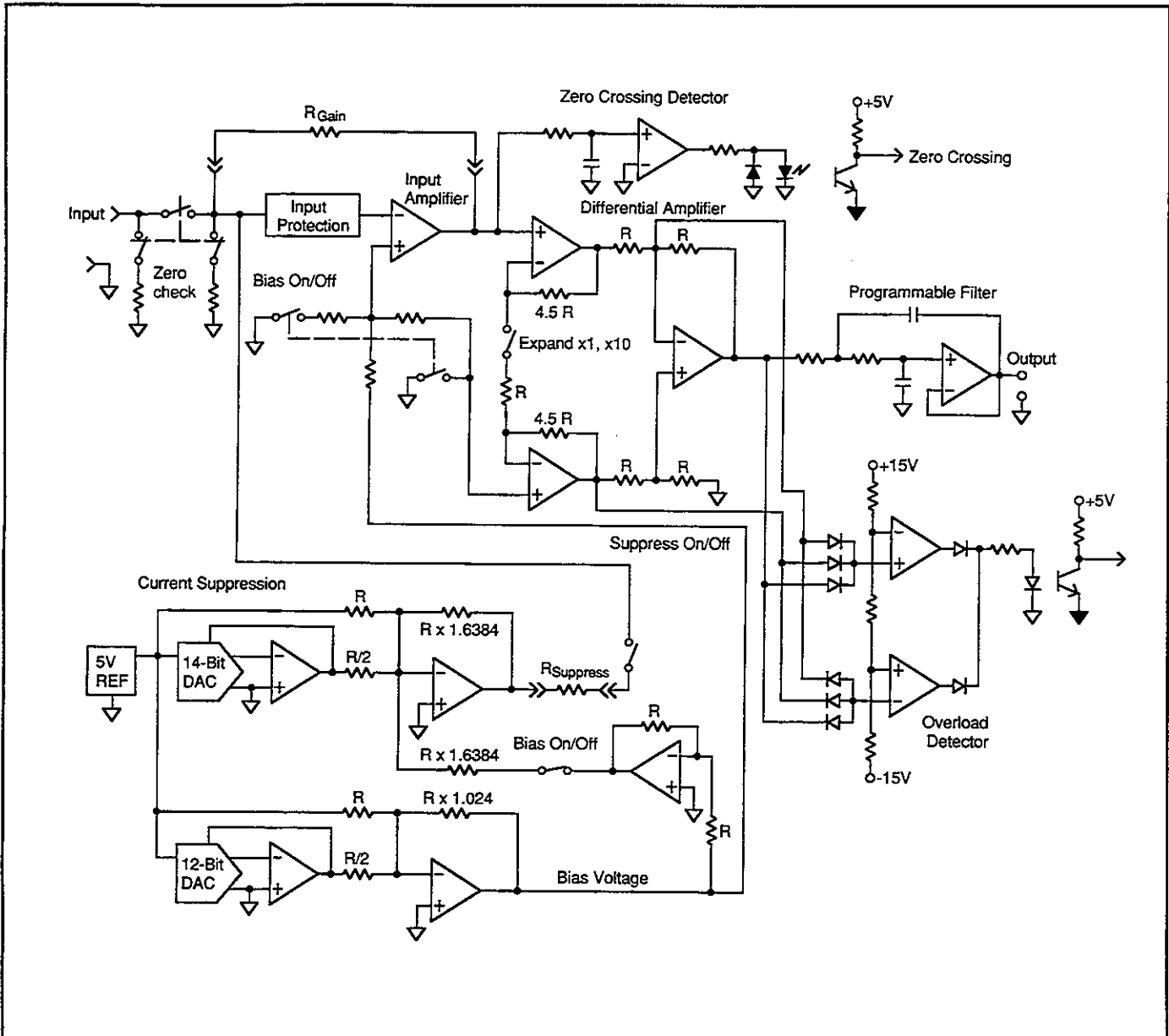

Figure 6-2. Analog Block Diagram

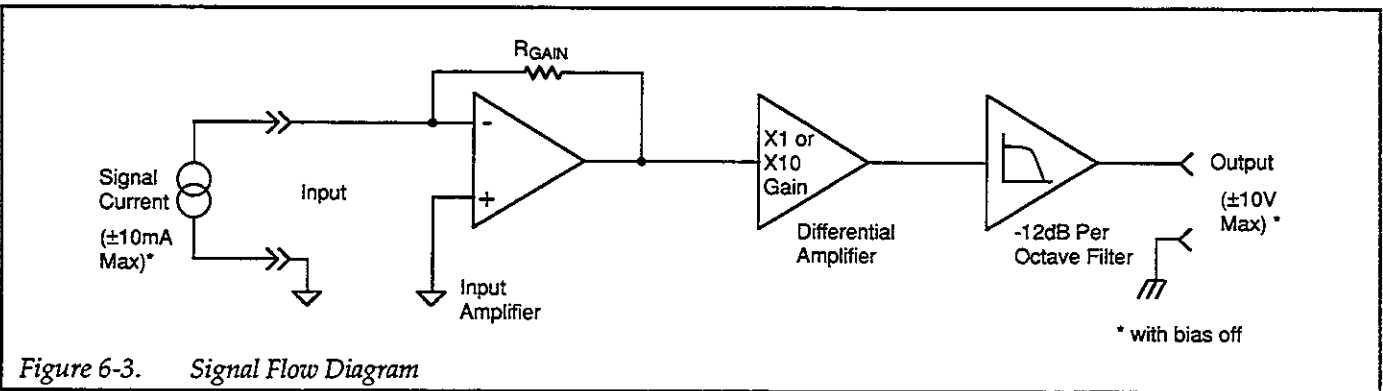

Figure 6-3. Signal Flow Diagram

The signal current is applied to the BNC INPUT connector through the zero check relay contacts. When zero check is enabled, the signal current is effectively shunted to input LO, and it is not applied to the input amplifier. When zero check is disabled, the signal current is applied through the protection circuits to the inverting input of the input amplifier, which is an operational amplifier. The protection circuits, of course, protect the input amplifier from over-voltage or over-current signals applied to the input.

The gain of the input amplifier is set by the feedback resistor, R_{GAIN} , which has a value from $10^3\Omega$ to $10^{10}\Omega$. The output of the input amplifier is a voltage that tracks the signal current; thus, the input amplifier performs the basic current-to-voltage conversion function of the instrument.

The output of the input amplifier is applied to the input of the differential amplifier. This amplifier performs two functions: it provides a selectable $X1$ and $X10$ gain, and it also subtracts the voltage bias level from the signal when voltage bias is enabled. From the differential amplifier, the signal is applied to the programmable filter where selectable-rise time filtering with -12dB per octave roll-off can be applied. The output of the filter is then routed to the output of the instrument.

The zero crossing detector is used during zero correction and auto-suppression to accurately determine when the output of the input amplifier is 0V . The overload detector does what its name implies – it detects when the output of any amplifier exceeds the predetermined overload level – approximately $\pm 10.4\text{V}$ in this case.

The current suppression signal is applied to the inverting terminal of the input amplifier when enabled, and the voltage bias source is applied to the noninverting terminal of the input amplifier. Since the inverting and noninverting terminals are at essentially the same potential, the programmed bias voltage will be applied across any device connected to the INPUT connector.

6.3.2 Input Amplifier

For the following discussion of the input amplifier, refer to the associated simplified schematic diagrams and the I-V converter and filter schematic, document #428-106, sheet 1 of 4, located at the end of Section 8.

Circuit Topology

The input amplifier of the Model 428 has been specially designed for low input bias current, low input offset voltage drift, and low input noise voltage. In order to achieve that goal, the compound op amp topology shown in the simplified diagram of Figure 6-4 is employed. The input transistors, Q106 and Q107 are specially chosen to maintain low input bias current, while an IC operational amplifier, U122, provides the overall open-loop gain and necessary drive capability of the operational amplifier stage.

Q106 and Q107A form a cascode pair and make up one-half of the differential input stage, while Q107B forms the other half. This cascode arrangement is used to minimize input bias current variations with changes in applied bias voltage.

In order to minimize noise, only the left half of the differential input stage is operational at frequencies above a few Hz. Capacitors C164 and C166 act to isolate Q107B noise from the rest of the circuit.

The current generator is necessary to minimize input offset voltage drift. The current generator is made up of Q108 and associated components. This circuit supplies a constant $400\mu\text{A}$ current output via the collector of Q108.

Input Amplifier Gain

The gain of the input amplifier is selected by switching in the appropriate feedback resistor (R166-R172). Switching is performed by relays K101-K107 and analog switches U120 and U121.

The gain of the amplifier in V/A is equal to the value of the gain resistor in ohms. The simplified gain model shown in Figure 6-5 demonstrates the gain factor of the input amplifier. The input current is I_{IN} , while the feedback current through the gain resistor is I_F .

Since no current flows into the ($-$) terminal of the op amp, $I_F = -I_{IN}$. In addition, since the ($-$) terminal is a virtual ground, the output voltage, V_{OUT} is simply the voltage developed across the gain resistor, R_{GAIN} . Thus,

$$V_{OUT} = -I_F R_{GAIN}$$

or,

$$V_{OUT} = -I_{IN} R_{GAIN}$$

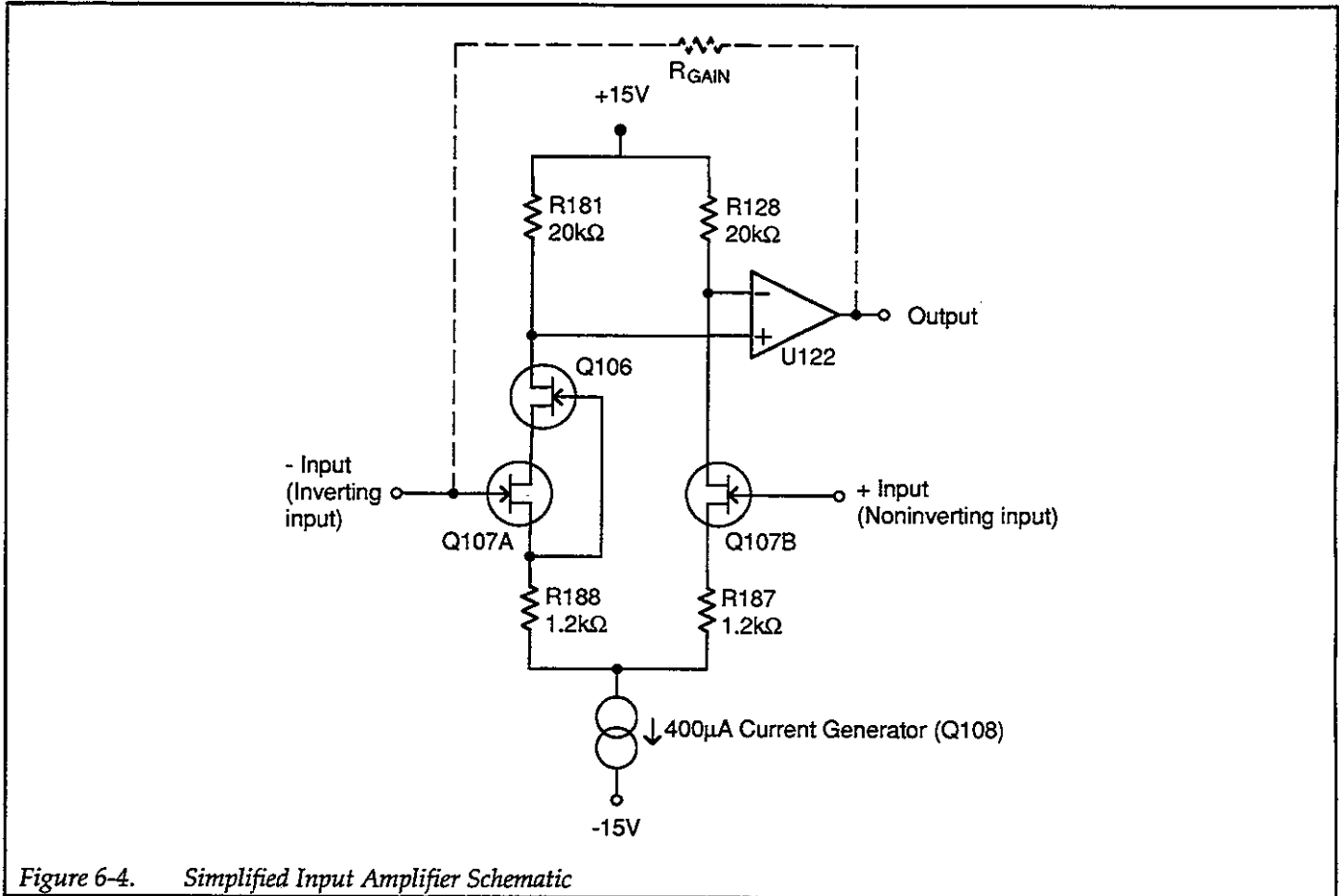

Figure 6-4. Simplified Input Amplifier Schematic

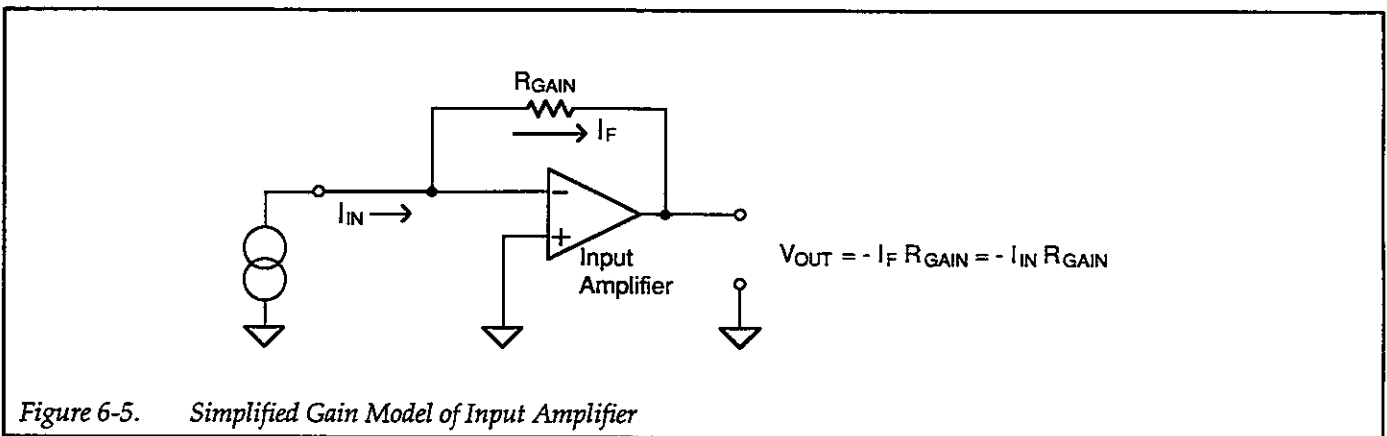

Figure 6-5. Simplified Gain Model of Input Amplifier

For example, R_{GAIN} has a value of $10^6\Omega$ with $10^6V/A$ gain. The output voltage with a $2\mu A$ input current is:

$$V_{OUT} = -(2 \times 10^{-6})(10^6)$$

$$V_{OUT} = -2V$$

Feedback Network Frequency Compensation

At higher gain settings, any parasitic capacitance (C_{FB} in Figure 6-6A) across the feedback gain resistance can become a problem. As frequency increases, the net imped-

ance of the feedback network decreases, reducing the gain accordingly.

circuit behaves as if R_{GAIN} were the only feedback element.

In order to minimize these undesirable effects, the RC compensation network shown in Figure 6-6B is used with 10^8 - 10^{10} V/A gain settings. Here, the unwanted shunt feedback capacitance is C_{FB} , and the compensation components are R_C and C_C . Compensation is optimum when $R_{GAIN}C_{FB} = R_C C_C$, and, under these conditions, the

Frequency compensation components include potentiometers R160-R164 and capacitors C145-C147. Two adjustments each for the 10^8 - 10^{10} V/A gain settings are included in order to optimize rise time while minimizing overshoot characteristics of the input amplifier at the respective gain settings.

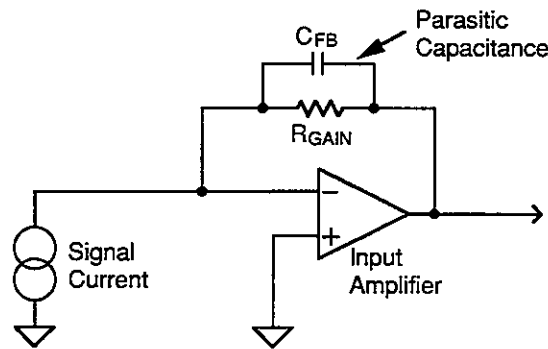

A. Feedback Network Parasitic Capacitance

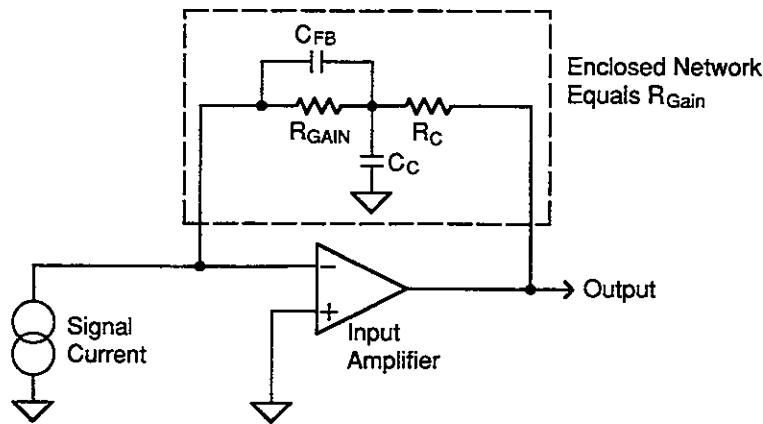

B. Adding Frequency Compensation

Figure 6-6. Frequency Compensation

Zero Check

Figure 6-7 shows the configuration of the input amplifier with zero check disabled (A) and enabled (B). When zero check is disabled, K110 contacts are closed, and K109 and K111 contacts are open. Under these conditions, the signal current is applied to the input amplifier through the contacts of K110.

When zero check is enabled, K110 contacts are open and K109 is closed. With this configuration, the signal current is shunted to common through R186, an 18Ω resistor. When zero correct is actuated, the voltage gain of the input amplifier is increased to X1000 dramatically by connecting R190 (100Ω) to the inverting input of the amplifier. This scheme is used to amplify any offsets so that the zero-correction process can more easily measure them and compensate for their effects.

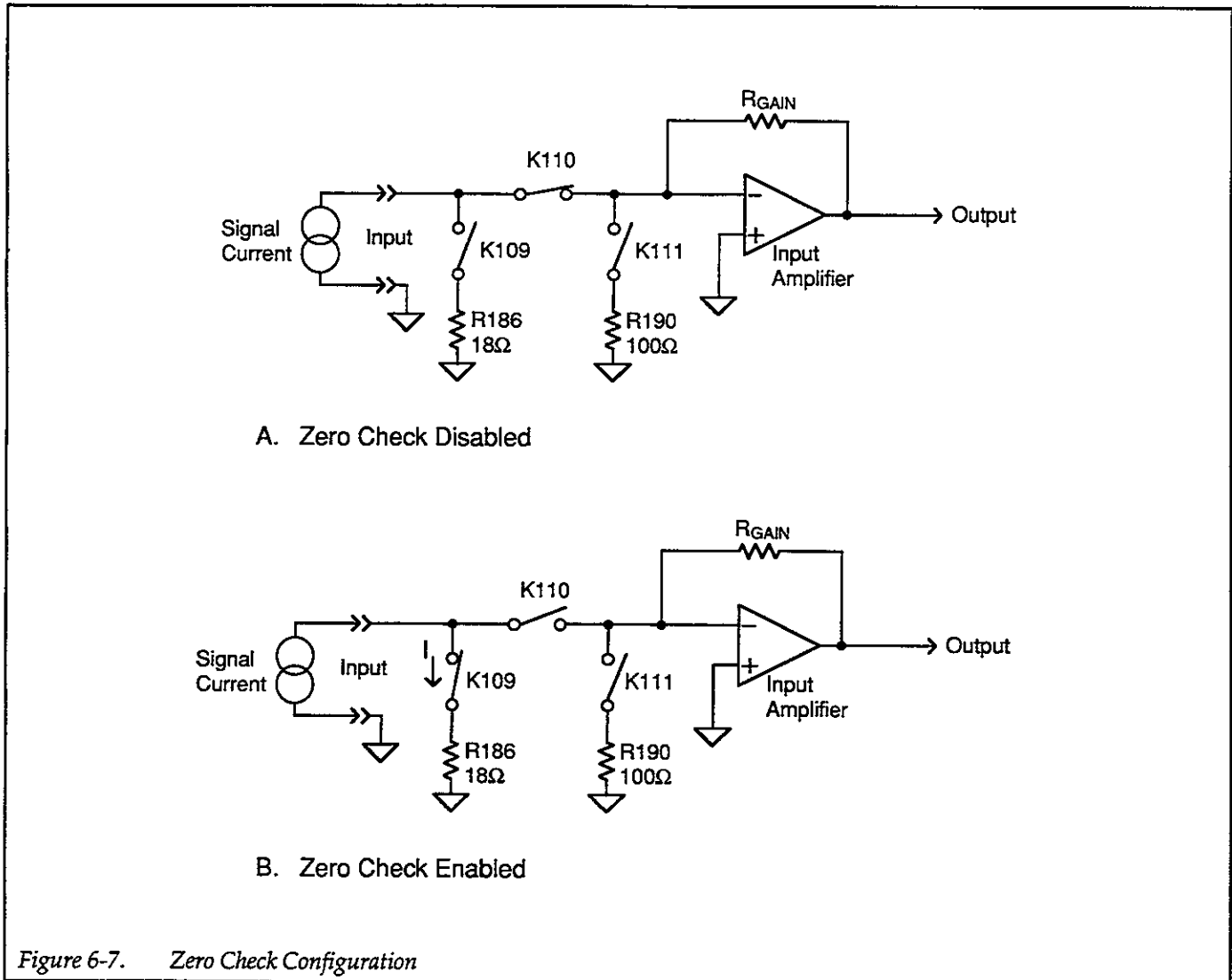

Figure 6-7. Zero Check Configuration

Input Protection

Input protection components for the differential input stage include Q104, Q105, and CR120. CR116 and CR117 perform similar protection functions for the operational amplifier U122 by limiting the maximum voltage that can be applied between its input terminals.

Voltage Bias Switching

The programmed voltage bias is applied to the noninverting input terminal of the input amplifier (Q107B gate) when enabled. The switching functions for the voltage bias are performed by Q102 and Q103. Q102 controls bias applied to the input amplifier, and Q103 switches the voltage bias applied to the differential amplifier (discussed below). The bias on/off signal from the micro-computer is sent through opto-isolator AT104 to the gates of Q102 and Q103 in order to control the bias on/off functions. When the two FETs are turned on, voltage bias is off; when these two FETs are off, voltage bias is applied to the gate of Q107B and to the differential amplifier.

The differential amplifier has two main functions: (1) to provide switchable X1 and X10 gain, and (2) to subtract the voltage bias level from the input amplifier output voltage when voltage bias is enabled.

Circuit Configuration

Figure 6-8 shows a simplified schematic diagram of the differential amplifier. The circuit consists of two main sections: the differential input stage, and the output stage. The differential input stage (U114A and U114B) allows X1 and X10 gain selection, and it also performs voltage bias subtraction. The output of the input amplifier is applied to the noninverting input of U114B, and the voltage bias level is applied to the noninverting input of U114A (if enabled).

The output stage (U117) converts the differential signal from the input stage to a single-ended output suitable for the filter stage that follows. The output stage has a gain of unity. Note that U117 is referenced to '0' ground while the input amplifier is reference to 'T' ground in order to maintain pseudo input isolation.

X1, X10 Gain Selection

Gain switching is performed by opening or closing the contacts of relay K100. When K100 is open, a gain of X1 is selected. Conversely, closing K100 selects a gain of X10. Under these conditions, the voltage gain, A_v , of the amplifier is:

6.3.3 Differential Amplifier

For the following discussion, refer the the I-V converter and filter amplifier schematic, drawing number 428-106, sheet 2 of 4 located at the end of Section 8.

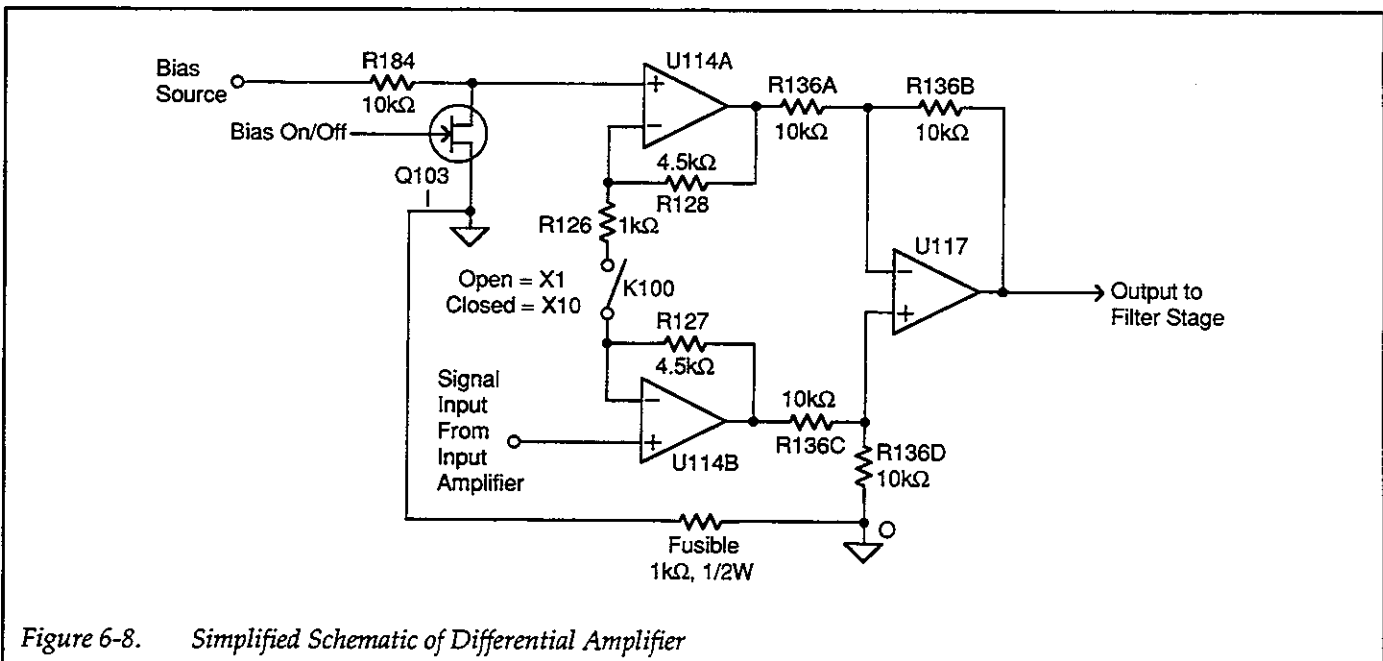

Figure 6-8. Simplified Schematic of Differential Amplifier

$$A_v = \frac{R126 + R127 + R128}{R126}$$

$$A_v = \frac{1k\Omega + 4.5k\Omega + 4.5k\Omega}{1k\Omega}$$

$$A_v = 10$$

Voltage Bias Subtraction

When the voltage bias source is enabled, it offsets the output of the input amplifier by a value equal to the bias voltage. In order to provide an output affected by input current alone, the differential amplifier has the means to subtract this offset.

When the voltage bias source is enabled, its voltage is applied to the noninverting input of U114A through R184, a 10kΩ resistor. This signal voltage shifts the output voltage of the differential amplifier by the same magnitude but of opposite polarity from the offset of the input amplifier. The net result is that the voltage bias source value present in the output signal is exactly canceled.

When the voltage bias source is disabled, Q103 turns on, effectively connecting the noninverting input of U114A to common. As a result, the differential amplifier offset is

essentially zero under these conditions. At the same time, the voltage bias source is also disconnected from the input amplifier, so the offset subtraction is not needed when voltage bias is disabled.

Output Offset Adjustment

The output offset adjustment, R158, is incorporated into the output stage of the differential amplifier. This adjustment allows overall output voltage offset to be set as close to zero as possible.

6.3.4 Filter

For the following discussion, refer to drawing number 428-106, sheet 2 at the end of Section 8.

The Model 428 uses a 2-pole, Bessel transfer function active filter designed for linear phase shift and constant delay throughout the passband. A simplified diagram of the filter is shown in Figure 6-9.

Table 6-1 summarizes component values for the various rise times, and Figure 6-10 shows a component switching diagram that indicates how the various R and C values are switched.

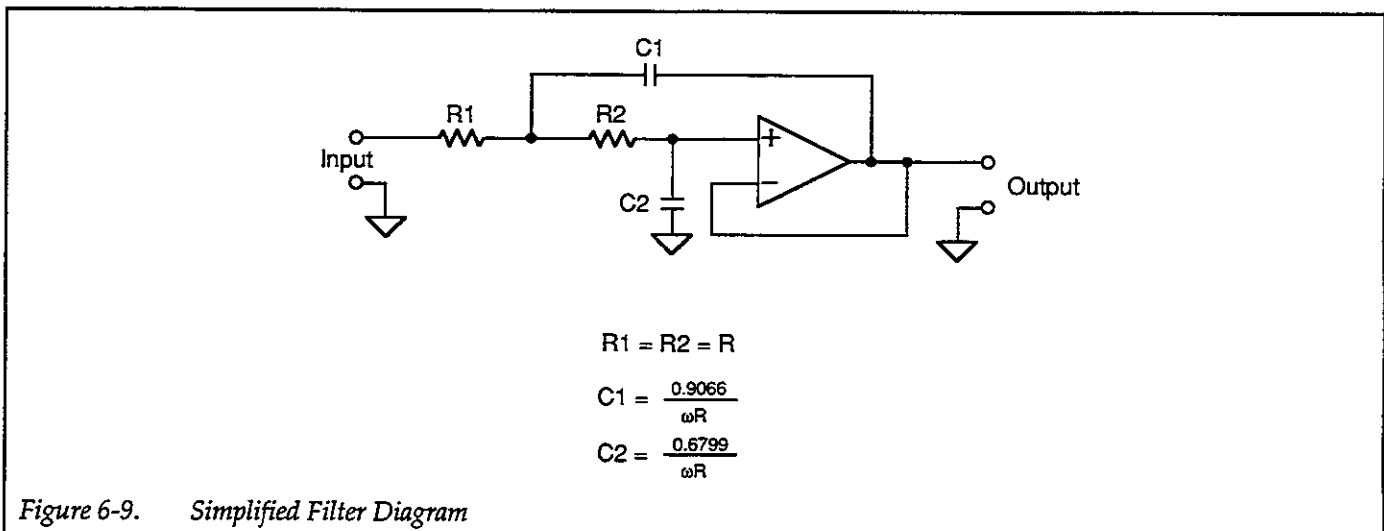

Figure 6-9. Simplified Filter Diagram

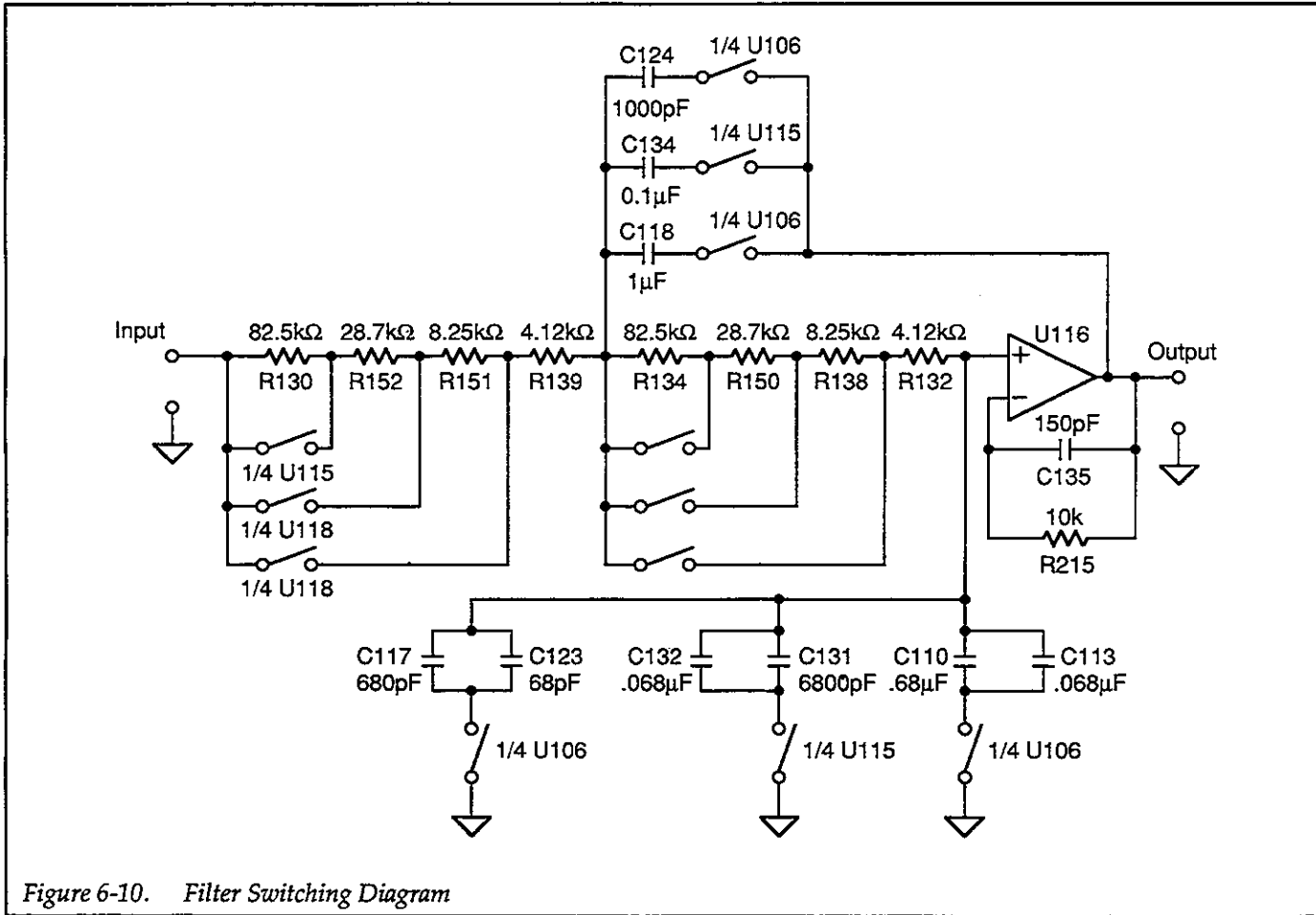

Figure 6-10. Filter Switching Diagram

Table 6-1. Filter Component Values

Rise Time	C1	C2	R	ω (rad/sec)
10 μ sec	1000pF	750pF	4.12k Ω	220k
30 μ sec	1000pF	750pF	12.4k Ω	73k
100 μ sec	1000pF	750pF	41.2k Ω	22k
300 μ sec	1000pF	750pF	124k Ω	7.3k
1msec	0.1 μ F	.0075 μ F	4.12k Ω	2.2k
3msec	0.1 μ F	.0075 μ F	12.4k Ω	730
10msec	0.1 μ F	.0075 μ F	41.2k Ω	220
30msec	0.1 μ F	.0075 μ F	124k Ω	73
100msec	1 μ F	0.75 μ F	41.2k Ω	22
300msec	1 μ F	0.75 μ F	124k Ω	7.3

6.3.5 Current Suppression

For the following discussion, refer to schematic drawing number 428-106 sheet 3, located at the end of Section 8.

Basic Configuration

As shown in Figure 6-11, the current suppression source is essentially a variable $\pm 5V$ voltage source in series with a resistor, which sets the suppression range. The suppression current is applied to the inverting input of the input amplifier.

Circuit Configuration

Figure 6-12 shows the basic circuit configuration of the current suppression circuit. The main parts of the circuit include the 14-bit DAC, 5V reference, amplifier stage, and the suppression range resistor.

The 5V reference (U124) provides a stable reference voltage for the 14-bit DAC, which converts digital control information into a 0 to $-5V$ signal with the aid of U127, a current-to-voltage converter. U125B amplifies and inverts the signal and provides a nominal $\pm 5V$ full scale output (the theoretical maximum output voltage is

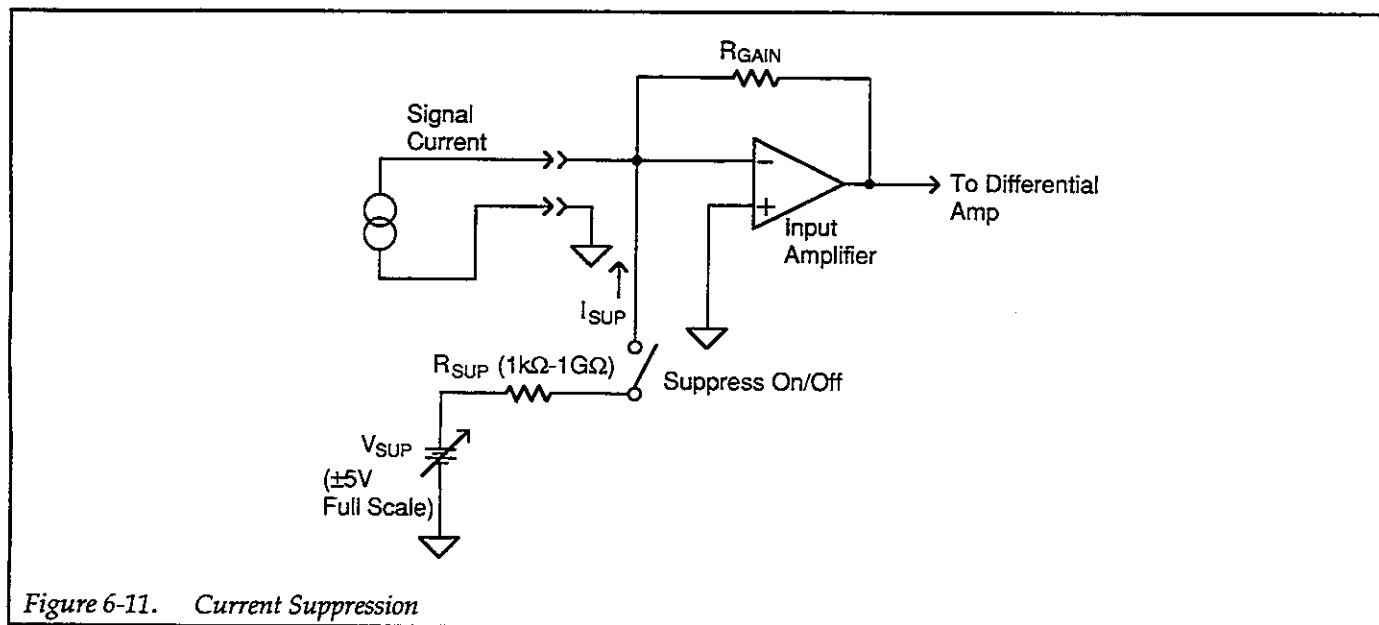

Figure 6-11. Current Suppression

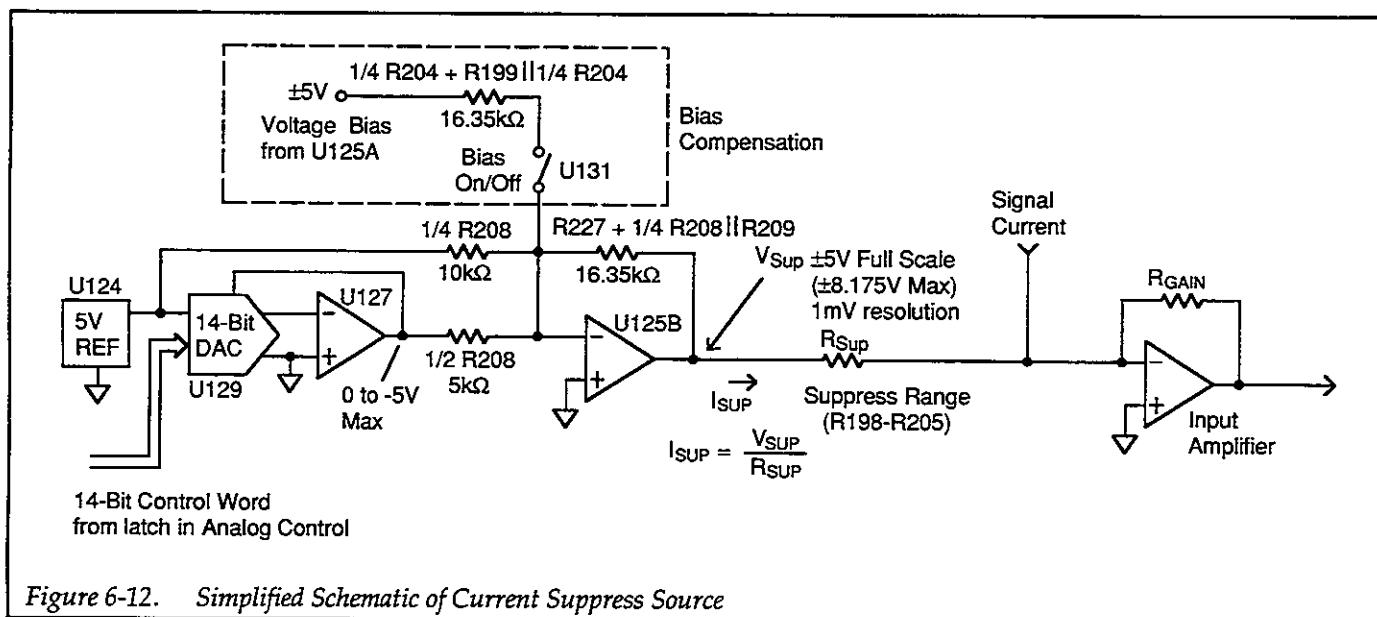

Figure 6-12. Simplified Schematic of Current Suppress Source

±8.175V maximum, but the actual output is software-limited to slightly more than ±5V).

value is chosen so that the suppress voltage source output changes by 1mV per LSB.

U125B has two signal inputs. The +5V reference voltage input provides an offset that converts the unipolar 0 to -5V DAC output into a bipolar output voltage. U125B gain for the DAC output signal is: $16.35/5 = 3.27$. That

The current suppression value is simply the value of V_{SUP} divided by the value of the range resistor, R_{SUP} (R198-R205). For example, on the ±5mA range, R_{SUP} has a value of 1kΩ. If V_{SUP} has a value of +2V, the suppression current is $2V/1k\Omega = 2mA$. Current range switching is performed by K113-K117.

Voltage Bias Compensation

When the voltage bias source is off (Figure 6-13A), the noninverting terminal of the input amplifier is at signal common. Since both the inverting and noninverting inputs of the amplifier must be at essentially the same potential, the inverting input is at signal common as well. Thus, the suppression current is simply the quotient of the suppression voltage and suppression resistor as outlined above.

When the voltage bias source is enabled, however, (Figure 6-13B), the noninverting terminal of the input amplifier is placed at voltage bias potential, which would alter the suppression current. To compensate for this offset, the voltage bias source level is applied to the inverting input of U125B through U131 and appropriate resistors when voltage bias is enabled. The resistor values are chosen so that the output of U125B is offset by an amount equal to the bias source value so that the current suppression value does not change with variations in voltage bias.

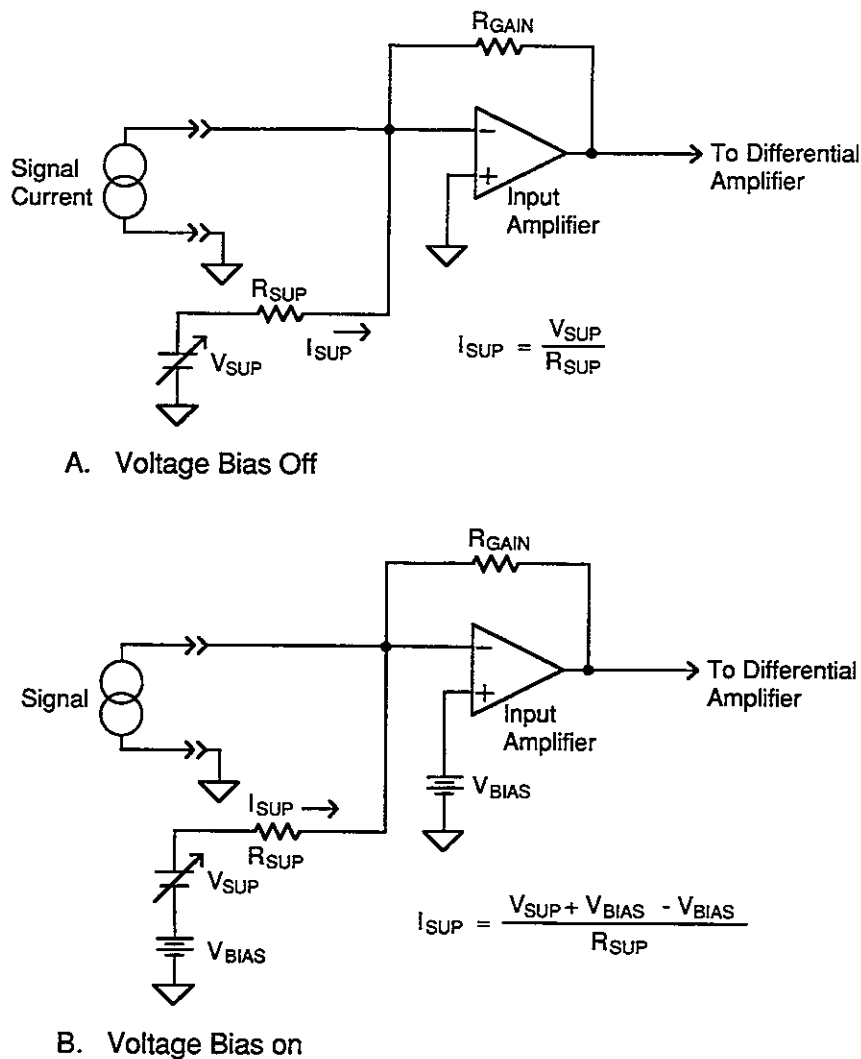

Figure 6-13. Voltage Bias Compensation

6.3.6 Voltage Bias

The voltage bias circuits are located on drawing number 428-106 sheet 3 at the end of Section 8.

Basic Configuration

Figure 6-14 shows the basic configuration of the voltage bias source. The circuit is a digitally-controlled variable voltage source that is applied to the noninverting input of the input amplifier when enabled. Note that the output of the input amplifier is offset by an amount equal to the bias voltage value.

Circuit Description

Figure 6-15 shows a simplified diagram of the voltage bias source. Since this circuit is very similar to the current suppression source covered previously, only a brief discussion is required. The main differences are:

- use of a 12-bit DAC (U126) instead of a 14-bit DAC
- stage gain (U123) is set to 1.024 so that 2.5mV = 1 LSB
- voltage output rather than current
- addition of voltage inverter stage (U125A) for voltage offset compensation of current suppression source.

The 12-bit voltage bias control word from the analog control circuits is converted to a 0 to -5V analog signal by U126 (a DAC) and U122 (a current-to-voltage converter). The unipolar signal is converted to bipolar by applying the +5V reference source to the inverting input of U123

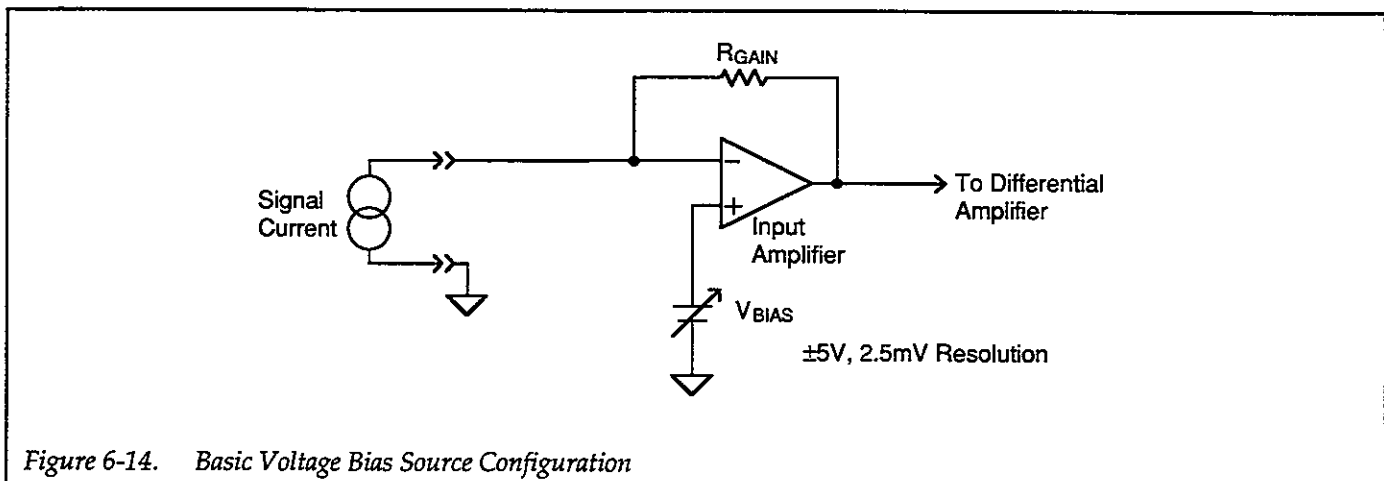

Figure 6-14. Basic Voltage Bias Source Configuration

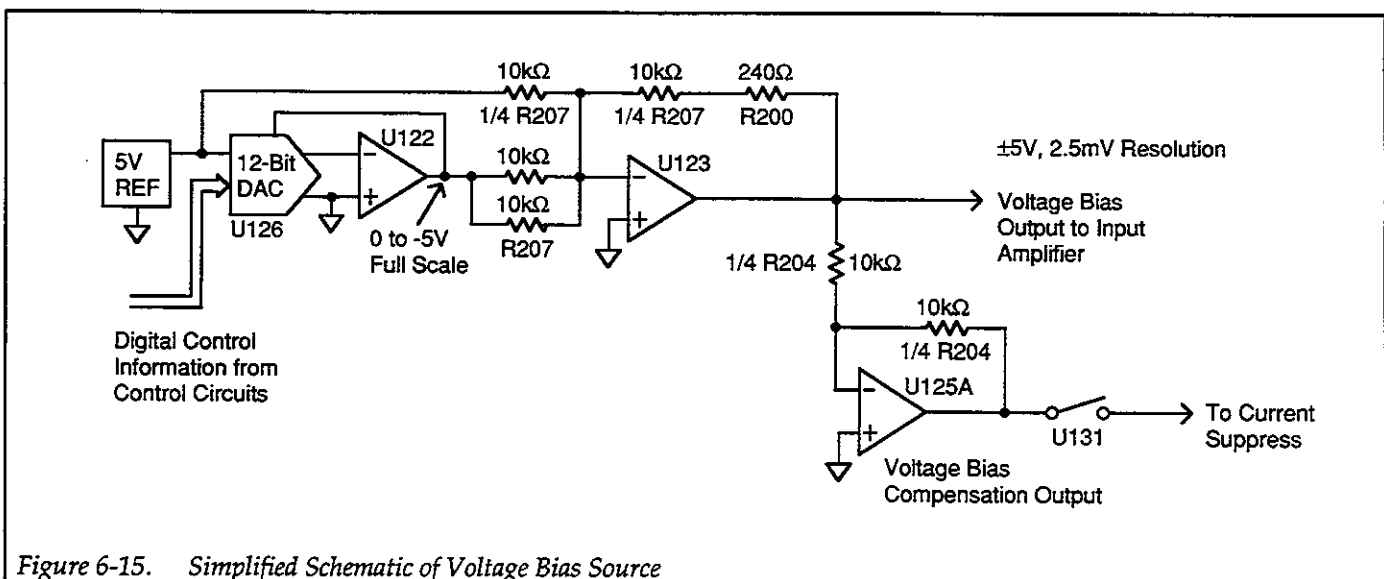

Figure 6-15. Simplified Schematic of Voltage Bias Source

through a 10kΩ resistor. The signal gain of this stage is set to 1.024 so that the output of the voltage source can be adjusted to 2.5mV per LSB.

U125A is a unity gain inverter that applies a bias voltage value of proper polarity to the suppression circuits for voltage bias offset compensation as discussed in paragraph 6.3.5.

6.3.7 Zero-crossing and Overload Detectors

The zero-crossing and overload detectors function similarly. The zero-crossing detector monitors the output of the input amplifier and is used to determine the exact zero point when auto-suppressing or zero correcting. The overload detector monitors the output of the differential amplifier and sends a signal to the microprocessor when the amplifier output exceeds approximately ±10.4V. Detailed diagrams for both circuits can be found on drawing number 428-106 sheet 2, located at the end of Section 8.

Zero-crossing Detector

Figure 6-16 shows a simplified schematic of the zero-crossing detector. The key part of the circuit is U113,

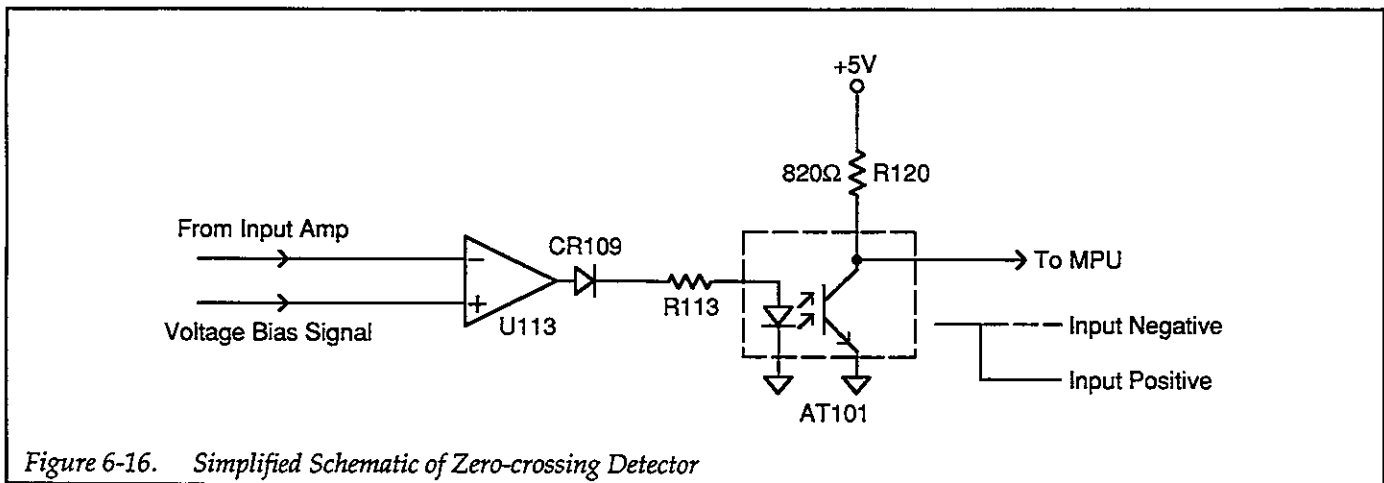

Figure 6-16. Simplified Schematic of Zero-crossing Detector

which is a comparator. The comparator has two inputs: the output of the input amplifier, and the voltage bias level. The voltage bias input is necessary so that the actual zero-crossing point is at voltage bias level rather than at 0V. Thus, the comparator effectively cancels the effects of the voltage bias level, concentrating instead on the true zero-crossing point based on the input signal alone. This action is provided only during auto-suppression; during zero correct, bias and suppression are off.

The output of the comparator is fed through opto-isolator AT101 to the microprocessor on the digital board. The output signal is high when the comparator input is negative and low when the comparator input is positive.

Overload Detector

Figure 6-17 shows a simplified schematic of the overload detector. The circuit is actually a window comparator made up of the two sections of U119. The "window" limits are set to about ±10.4V by the voltage divider made up of R137, R140, and R141. The output of the window comparator is fed through opto-isolator AT100 to the MPU on the digital board. The output is high for normal signal levels (<±10.4V), and the output is low for overload conditions (>±10.4V).

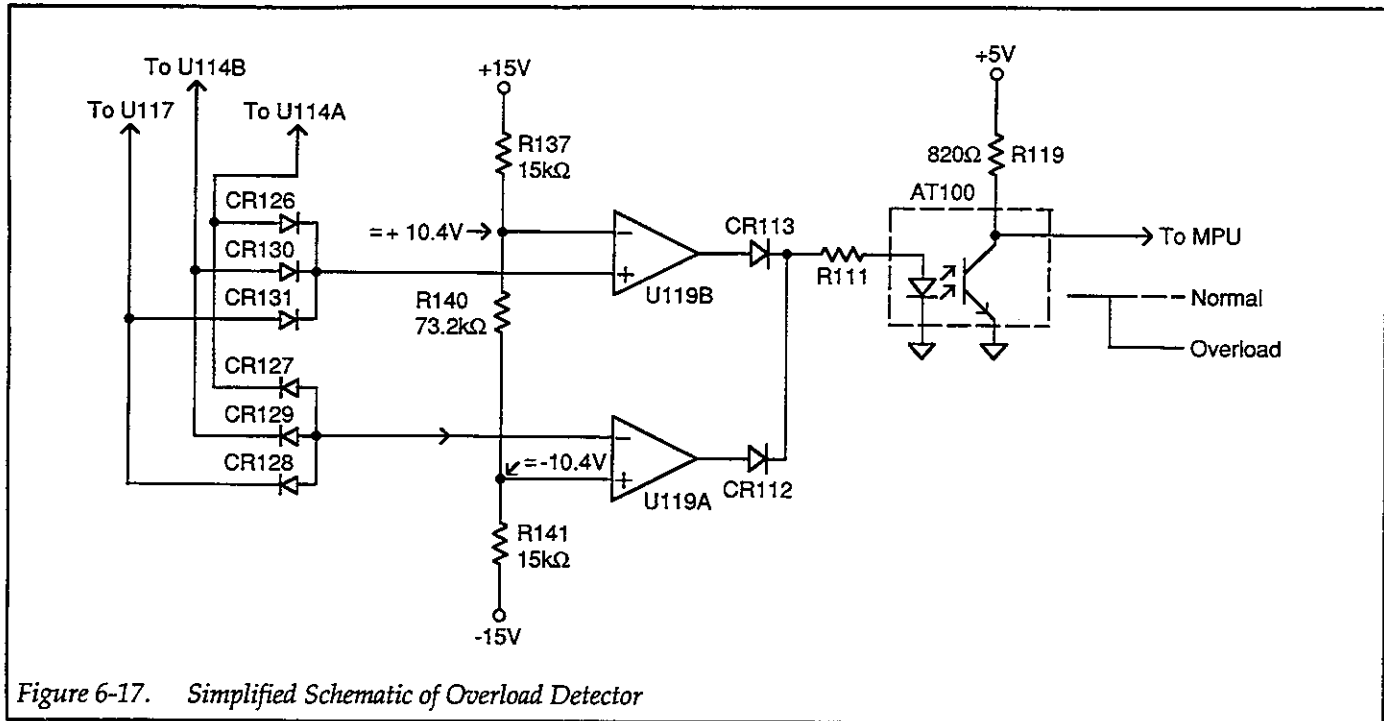

Figure 6-17. Simplified Schematic of Overload Detector

Note that the window comparator monitors the outputs of all three operational amplifiers in the differential amplifier.

6.3.8 Analog Control Circuits

The analog control circuits, which can be found on drawing number 428-106, sheet 3, control virtually all aspects of the analog section of the instrument, including bias voltage, suppress, gain, and rise time. The following paragraphs discuss the key aspects of the analog control circuits.

Block Diagram

Figure 6-18 shows a simplified block diagram of the analog control circuits. A synchronous serial data transmission scheme is used to pass digital control information through opto-isolators AT102 and AT103 to several shift registers that store the control information (U102, U107-U109, U128, and U130). The three data transmission lines are:

- ANALOG DATA: transmits the serial control data
- ANALOG CLOCK: controls the data transmission rate
- ANALOG STROBE: latches control information into command registers

Control Word

A 32-bit control word, shown in Figure 6-19, is used to control the various functions. Most of the bits have three purposes. They control either the bias DAC, the suppress DAC, or the remaining control functions. Which of the three purposes each bit serves at a particular time depends on the strobe decode circuits discussed below.

Strobe Decode

U102 and sections of U101 perform the strobe decoding functions. These circuits determine which of three sections will latch in the serial data being transmitted. Once the 32-bit control word has been shifted in, it is latched into one of three sections, depending on the strobe decoding state: bias DAC (U126), suppress DAC (U129) or the command registers for all other control functions (U107-U109). For example if the QA bit of U102 is set, control information will be latched into the suppress DAC when ANALOG STROBE is set. If QB of U102 is set, control information will be latched into the bias DAC, while QC controls strobing of control information to all other control functions.

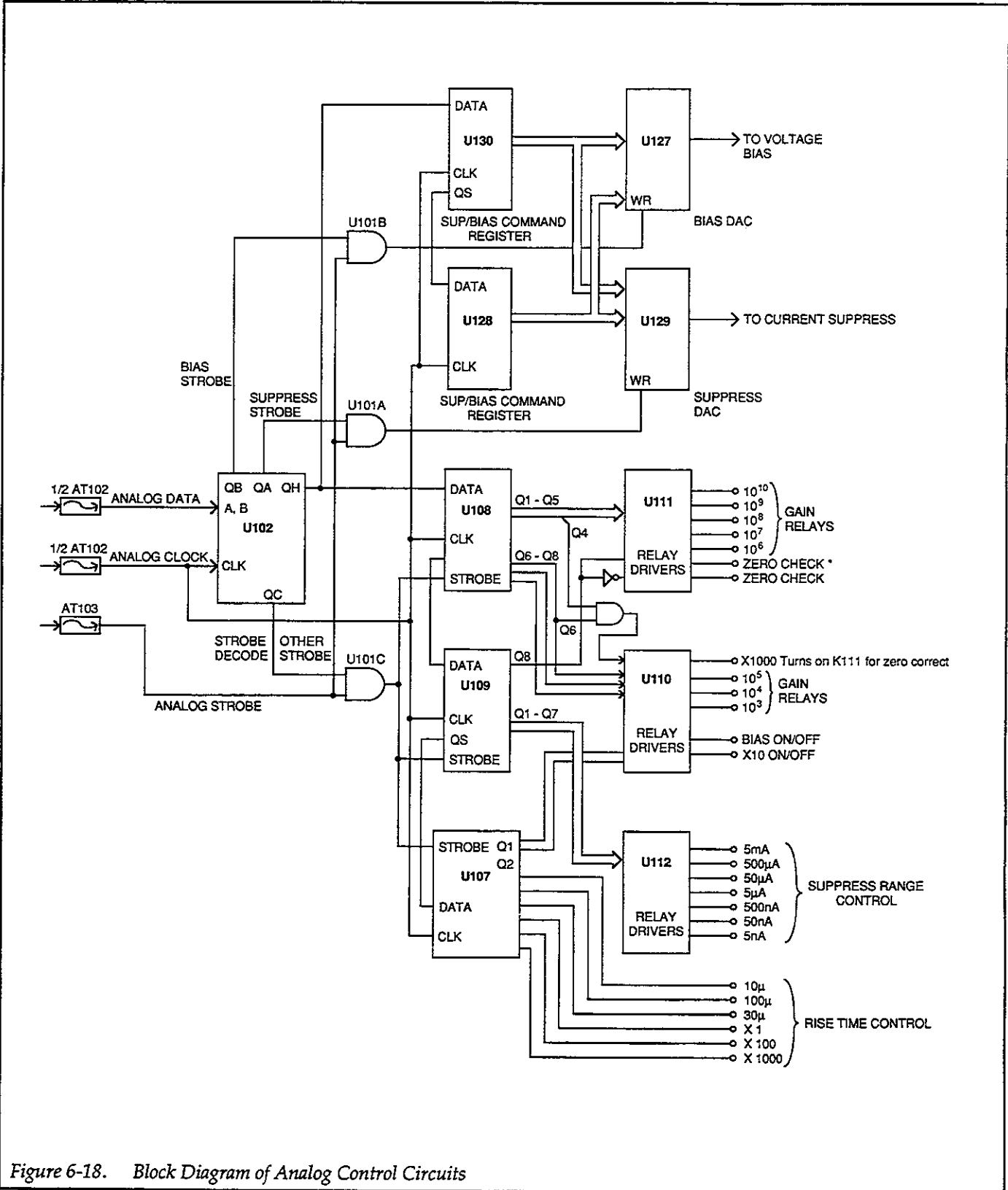

Figure 6-18. Block Diagram of Analog Control Circuits

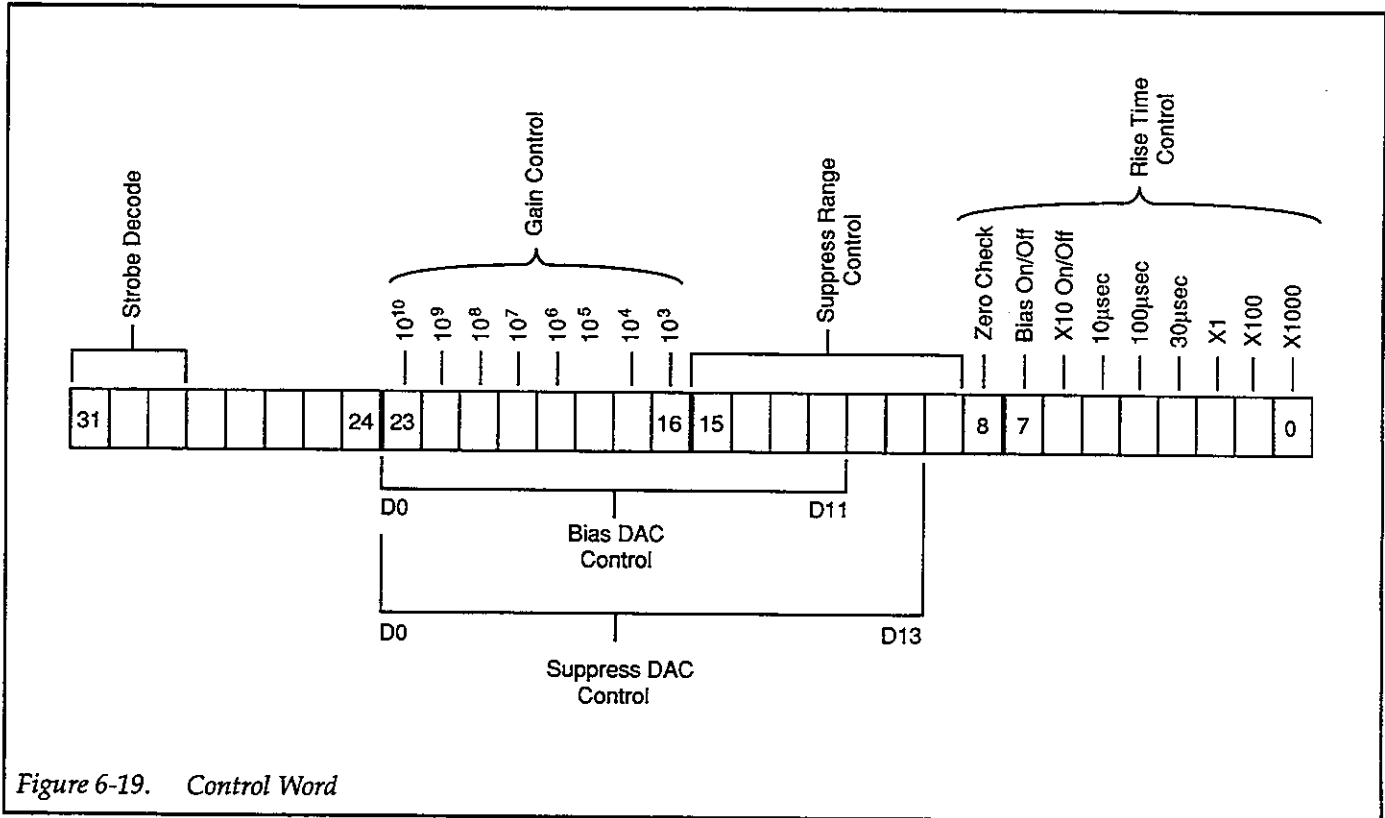

Figure 6-19. Control Word

Relay Drivers

The command registers cannot directly drive the various relays. Several relay drive ICs (U110-U112) provide the necessary drive capabilities.

6.4 DIGITAL CIRCUITS

The paragraphs below give an overview of the digital circuits, which can be found on drawing numbers 487-146 and 428-116 at the end of Section 8.

NOTE

The digital board shown in drawing number 487-146 is used in several different instruments and shows some information that does not pertain to the Model 428.

6.4.1 Digital Block Diagram

Figure 6-20 shows a block diagram of the most important digital circuits. Key sections include the microcomputer (RAM, ROM, VIA, EEROM, and VIA), the display board,

and the IEEE-488 interface (used in the Model 428-PROG only). The various sections are discussed in detail in the following paragraphs.

6.4.2 Microcomputer

The microcomputer controls all operating aspects of the instrument. The various sections of the microcomputer include the 68B09 MPU, the memory circuits, and I/O (VIA) circuits.

Microprocessor

U509 is a 68B09 8-bit microprocessor that controls the instrument. The processor has an 8-bit data bus (D7-D0), a 16-bit address bus (A15-A0), as well as a number of control lines.

Y500 is an 8MHz crystal that provides a time base for the internal MPU clock. The clock signal is internally divided down to 2MHz and is used as a bus clock via the E and Q lines.

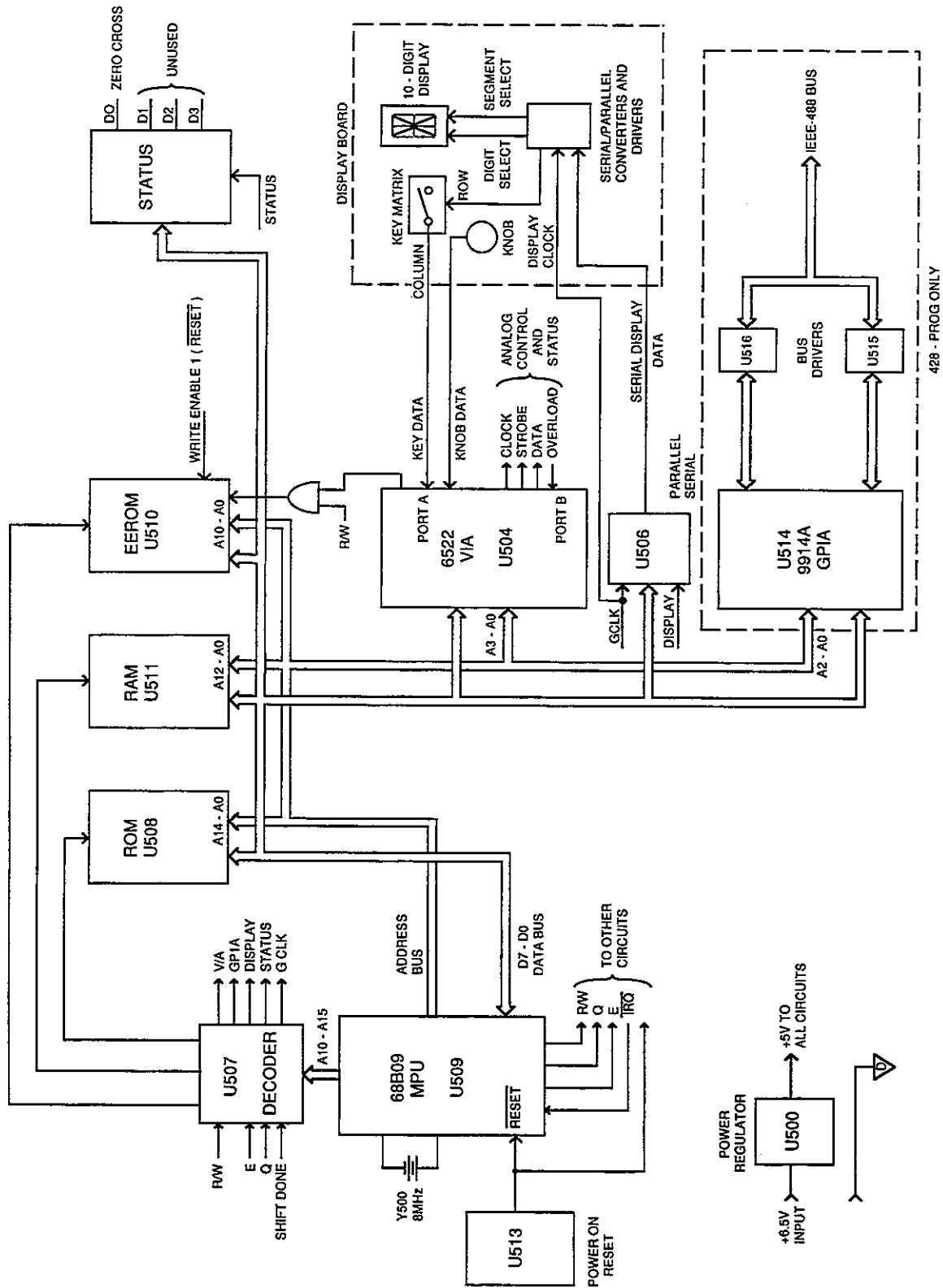

Figure 6-20. Digital Block Diagram

Power-on reset for the MPU is provided by U513. The reset signal is also used to inhibit writing to the EEROM during power-up.

Memory Circuits

U508, a 32K byte PROM, contains the instruction coding for the MPU. Working storage for the MPU is provided by U511, an 8K byte RAM. Non-volatile storage for data such as zero-correction constants and power-on defaults is provided by EEROM U510.

Address Decoder

U507 is a PAL that performs the address decoding for the various memory and I/O circuits, and it is also instrumental in the operation of the serial port (discussed below). U507 monitors the states of the A15-A10 address lines, and it selects the appropriate section of the memory map accordingly. A memory map is shown in Figure 6-21.

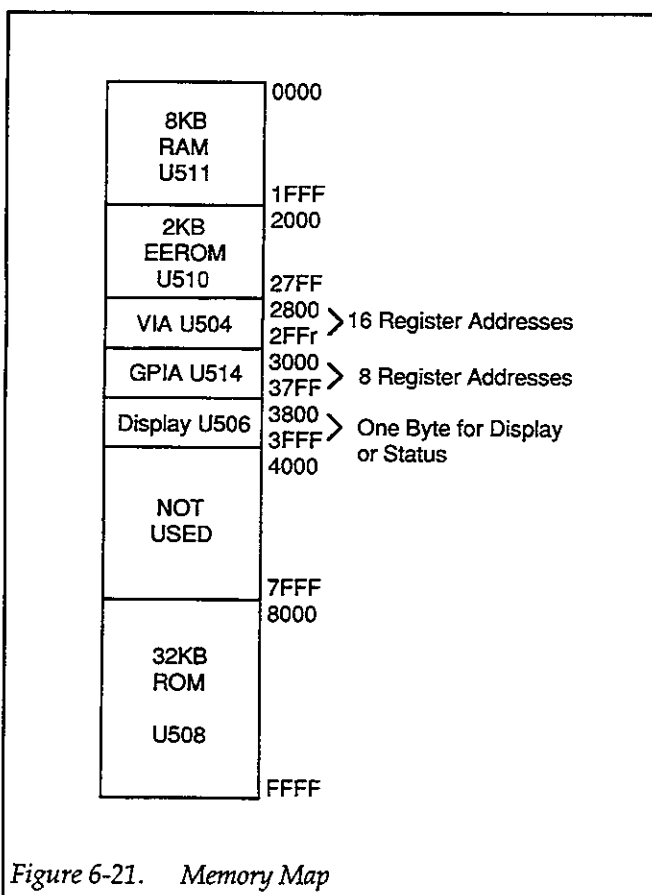

Figure 6-21. Memory Map

I/O Ports

U507, a 6522 VIA (Versatile Interface Adapter) provides much of the I/O for the microcomputer. Port A reads keyboard and knob data, while port B provides control (ANALOG DATA, ANALOG STATUS, ANALOG STROBE) and status (overload, zero crossing) I/O. Figure 6-22 shows the analog control interface including registers and switches located on the analog board.

Serial Port

The serial port provides high-speed serial data transmission to the display and keyboard circuits located on the display board. Figure 6-23 shows a simplified block diagram of the serial port.

The 2MHz clock for the port is provided by the PAL, U507. U506 is a parallel-to-serial converter used to shift out display and keyboard data to circuits located on the display board. U503 is a bit-shift counter and provides the SHIFT DONE signal when all eight bits are shifted out at the clock rate.

The basic data transmission sequence is as follows:

1. The byte to be transmitted is written to U506. The act of writing this byte not only parallel loads U506, but it also clears the shift counter, U503, via its CLR line. Clearing U503 enables the GCLK (gated clock) signal supplied by U507. GCLK becomes the clock signal after inversion by U502.
2. The GCLK pulses applied to U506 cause the 8-bit data word to be shifted out the DISPLAY DATA line. At the same time, the display clock pulses cause the shift counter, U503, to count up, one count per clock cycle.
3. After all eight bits are shifted out, the shift counter generates the SHIFT DONE signal to indicate that the entire byte has been shifted out. This signal is fed back to the PAL, U507, which halts the GCLK signal to stop the shifting process.
4. The process in steps 1 through 3 repeats for four successive bytes until all the necessary information is transmitted to the display and keyboard circuits.
5. The DISPLAY LEFT line, which is controlled by the PA6 terminal of U504, is brought low to enable the outputs of the registers on the display board.

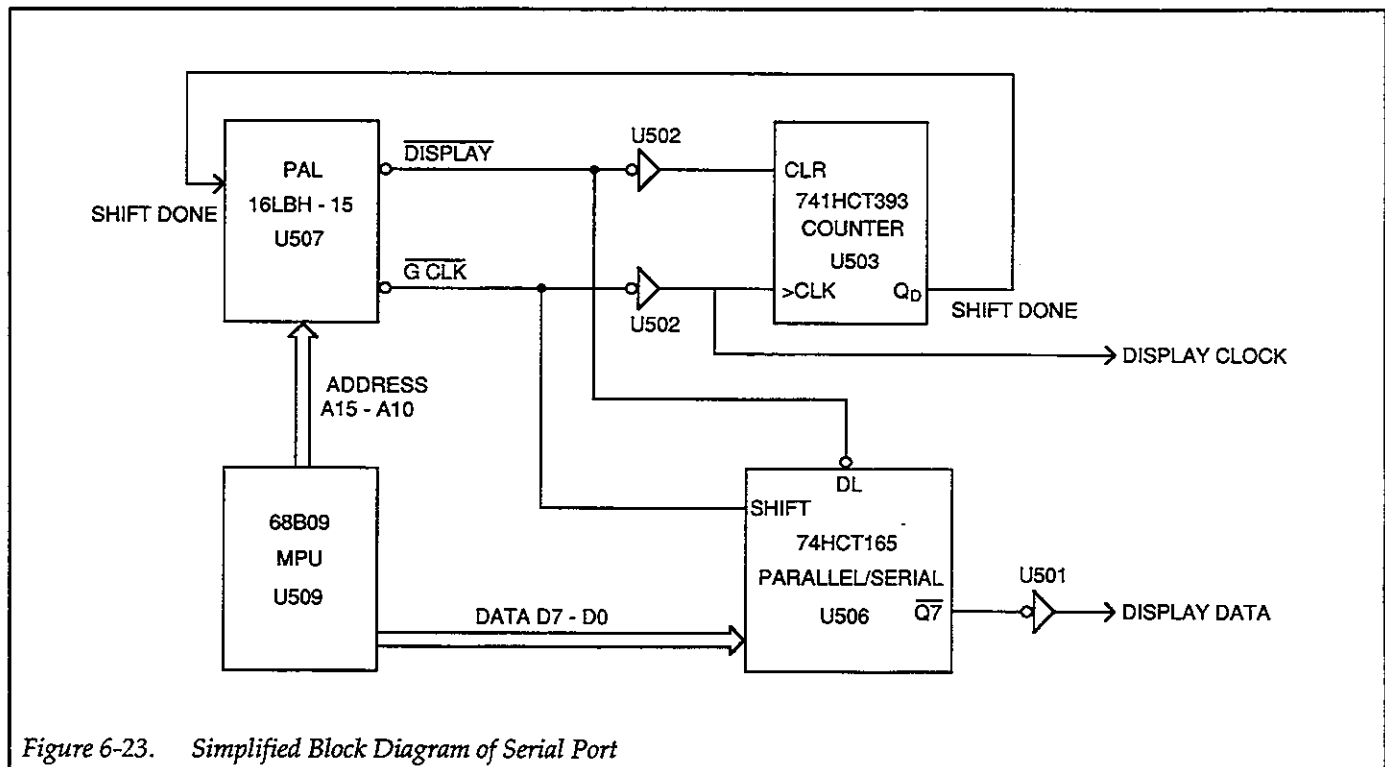

Figure 6-23. Simplified Block Diagram of Serial Port

6.4.3 Display/Keyboard

The display and keyboard circuits are shown on drawing number 428-116, located at the end of Section 8. Figure 6-24 shows a block diagram of the display and keyboard circuits.

Display Multiplexing

The ten digits of the display and the group of separate LEDs are multiplexed, which means that only one digit (or the group of separate LEDs) is actually on at any given time. Because of the rapid multiplexing rate, display flicker is not visible to the user.

For each digit, display data is clocked in via the DISPLAY DATA line using the DISPLAY CLOCK and the transmission sequence discussed in the previous paragraphs. This data is shifted into four shift registers located on the display board. U401 and U409 hold segment data, and U406 and two bits of U411 store selected digit data. One bit of U411 is used to control the separate LEDs, while

five bits of U411 are used to strobe the five rows of the keyboard matrix.

After all data are shifted in, the DISPLAY LEFT line is brought low to enable into the U401 and U409 outputs. This action causes the pertinent segments of the selected digit (or the selected separate LEDs) to turn on. The process repeats for a total of 11 times per display update cycle so that each display digit or LED can be turned on as appropriate.

Segment drive capabilities are an integral part of U401 and U409, and external current-limiting resistors are required and are located in U400 and U407. Drive capability for U406 and U411 are provided by U405 and U410 respectively.

Reading the Keyboard

The front panel keys are organized as a 5-row by 3-column matrix. In order to determine which key is closed, each row in succession is strobed by setting the appropriate output of U411 high. For each row, the three columns

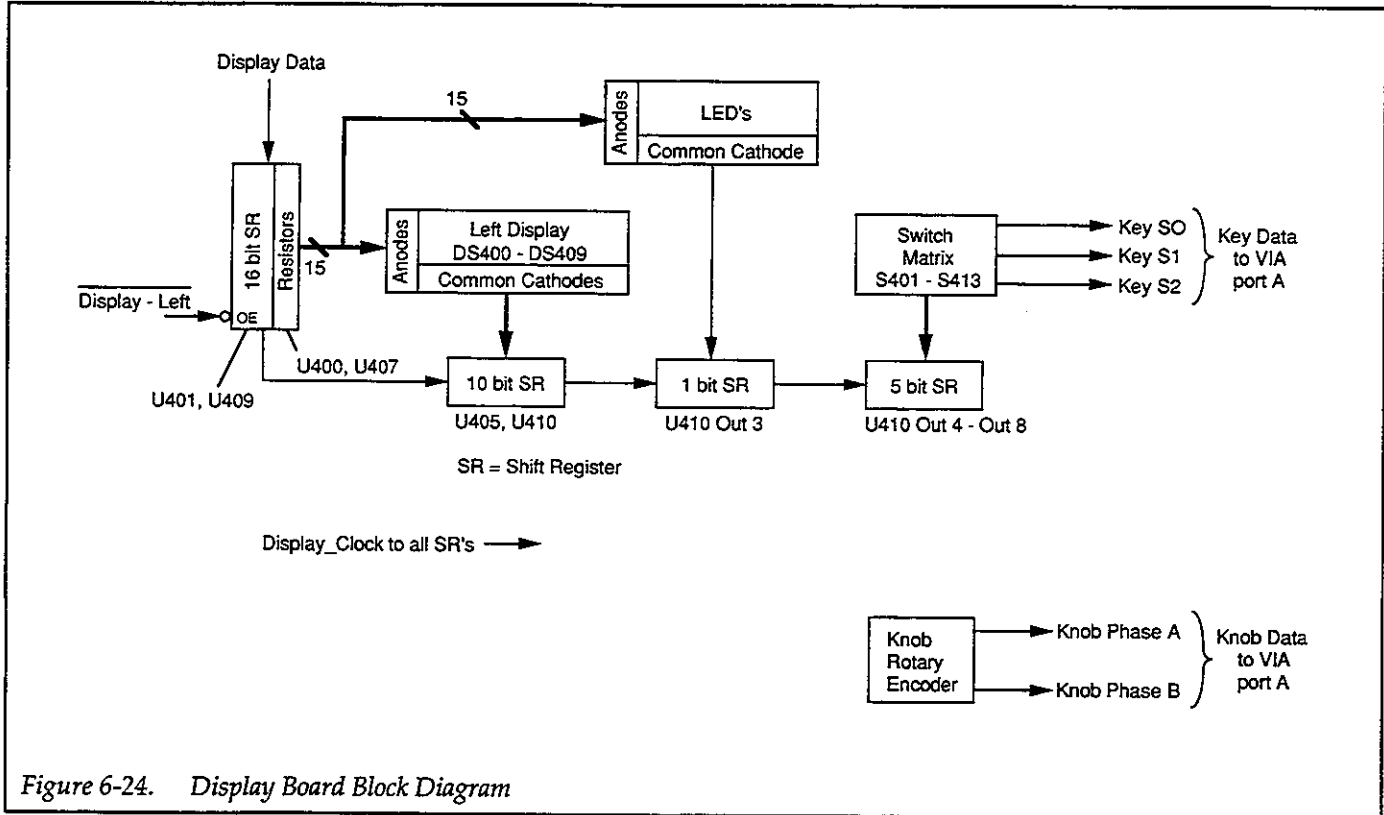

Figure 6-24. Display Board Block Diagram

are read through the VIA on the digital board. Knob data is read through the VIA as well.

6.4.4 IEEE-488 Interface

The IEEE-488 interface is located on drawing number 487-146, page 2, at the end of Section 8. Note that the IEEE-488 interface is not present in the Model 428-MAN.

The interface includes three ICs. U514 is a 9914A GPIA (General Purpose Interface Adapter) that performs many bus control functions such as handshaking automatically, minimizing MPU overhead. Bus drive capabilities are provided by U515 and U516. U516 supports the data lines (DIO1-DIO8), and U515 supports management and handshake lines.

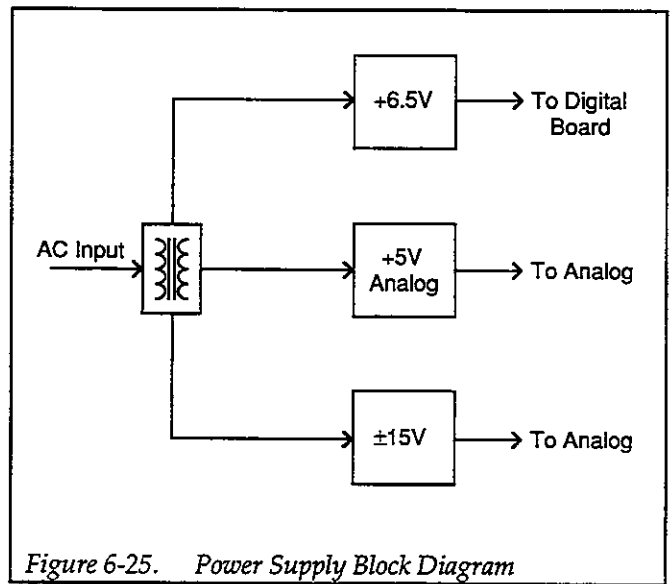

Figure 6-25. Power Supply Block Diagram

6.5 POWER SUPPLIES

Figure 6-25 shows a block diagram of the power supply section. The power supply schematic is located on drawing number 428-106 sheet 4, located in Section 8.

6.5.1 AC Line Input

The AC power line voltage is applied through J1001 to the power transformer, T100. S101 is the on/off switch, and F100 is the line fuse that provides protection to the line voltage input circuits. S100 switches between 90-125V and 180-250V AC operation.

6.5.2 $\pm 15V$ Supplies

The $\pm 15V$ supplies power all the amplifier stages on the analog board. Rectification for the $\pm 15V$ supplies is performed by CR102, while C106 and C108 provide filtering. U103 regulates the +15V supply, and U104 regulates the -15V supply. Output filtering is performed by C105 and C109.

6.5.3 +5V Supply

The +5V supply powers the analog control circuits and relays located on the analog board. CR101 rectifies incoming AC, and C103 filters the rectifier output. U105 regulates the supply to its nominal +5V value, and C104 provides output filtering.

6.5.4 +6.5V Supply

The +6.5V supply powers circuits on the digital board. CR100 rectifies the 8V AC input voltage, while C107 filters the output. The output of the +6.5V supply is further regulated to +5V by a separate power regulator located on the digital board (U500). This +5V supply also supplies the display board.

SECTION 7

Service Information

7.1 INTRODUCTION

This section contains information on servicing the Model 428.

WARNING

The information in this section is intended only for qualified service personnel. Do not perform these procedures unless you are qualified to do so.

Section 7 includes the following:

7.2 Line Fuse Replacement: Covers the procedure for replacing the line fuse.

7.3 Handling and Cleaning Precautions: Discusses handling and cleaning of sensitive, high-impedance areas of the instrument.

7.4 Special Handling of Static-Sensitive Devices: Outlines precautions that should be taken when handling static-sensitive parts.

7.5 Adjustments: Describes the procedures for offset and high-frequency compensation adjustments.

7.6 Disassembly: Details the disassembly and assembly procedures for the instrument.

7.7 Troubleshooting: Gives troubleshooting procedures for the various circuits within the unit.

7.8 Resistor Replacement: Covers the steps necessary for replacing the high-gain resistors.

7.2 LINE FUSE REPLACEMENT

The rear panel line fuse protects the power line input. Use the procedure below to replace this fuse.

WARNING

Disconnect the instrument from the power line and from all other equipment before replacing the line fuse.

1. With the power off, place the end of a flat-blade screwdriver into the slot in the line fuse holder. Push in gently, and rotate the fuse carrier one-quarter turn counter-clockwise. Release pressure, and the internal spring will push the fuse and carrier partially out of the holder. Grasp the fuse carrier, and pull the fuse completely free of the holder.
2. Remove the fuse from the carrier, and replace it with a good fuse of the type recommended in Table 7-1.

CAUTION

Use only the specified fuse type, or instrument damage may occur.

3. Install the new fuse and carrier into the holder by reversing the above procedure.

Table 7-1. Replacement Fuses

Line Voltage	Fuse Type	Keithley Part No.
105-125V, 90-110V	4/10A, Slow Blow, 3AG	FU-92
210-250V, 180-220V	2/10A, Slow Blow, 3AG	FU-93

7.3 HANDLING AND CLEANING PRECAUTIONS

Special precautions should be used when servicing certain high-impedance areas to avoid contamination that could degrade performance. Critical high-impedance areas include the input side of the input amplifier and the resistor board containing the 10^8 , 10^9 , and 10^{10} gain resistors.

tors (R167-R169). Critical board areas can be identified as those with the Teflon®-insulated standoffs.

If it is necessary to service the the circuit boards, do not touch the high-impedance areas or the high-gain resistors while working on other areas of the board. If it is necessary to use solder on the circuit board, observe the following precautions:

- Use Freon® TMS or TE or the equivalent along with a clean, soft brush to remove the flux from the circuit board when the repair is complete.
- Be careful not to spread flux to other areas of the circuit board.
- Once the flux has been removed, swab only the repaired and cleaned area with clean methanol, then blow dry the board with dry nitrogen gas.
- After thorough cleaning, place the instrument in a 50°C low-humidity environment for several hours before use.

7.4 SPECIAL HANDLING OF STATIC-SENSITIVE DEVICES

CMOS and other high-impedance devices can be damaged by static discharge. When handling such devices, use the following precautions:

1. Such devices should be transported only in containers specially designed to prevent or dissipate static

build-up. Typically, these devices will be stored in anti-static containers made of specially-treated plastic or foam. Keep these parts in their original containers until ready for installation.

2. Remove the devices from their protective containers only at a properly-grounded work station. Also ground yourself with a suitable wrist strap while working with such devices.
3. Handle the devices only by the body; do not touch the pins.
4. Any printed circuit board into which the device is to be inserted must first be grounded to the bench or table.
5. Use only anti-static type de-soldering tools and grounded-tip soldering irons.

7.5 ADJUSTMENTS

The following paragraphs give the procedures for the output offset adjustment and 10^8 - 10^{10} gain rise time adjustments.

7.5.1 Recommended Test Equipment

Table 7-2 summarizes the test equipment required for the offset adjustment, and Table 7-3 lists recommended equipment for the rise time adjustments. Note that the 10-15pF capacitor should be connected and mounted in the shielded component box, as shown in Figure 7-1.

Table 7-2. Test Equipment Recommended for Offset Adjustment

Description	Specifications	Manufacturer and Model
DMM BNC cable BNC/dual banana plug	300mV range, $\pm 0.008\%$ accuracy Low noise 50Ω	Keithley 199 Keithley 4801 or 7051 Pomona 1269

Table 7-3. Test Equipment Recommended for Rise Time Adjustments

Description	Specifications	Manufacturer and Model
Function generator	0.1V, 1V, 10V p-p triangle wave	HP 3312A
Oscilloscope	20MHz bandwidth	TEK 2205
10-15pF capacitor	Any dielectric suitable	Keithley C-64-10p
Shielded component box	BNC male, BNC female	Pomona 2391
BNC cables (2)	Low noise for 428 input	4801

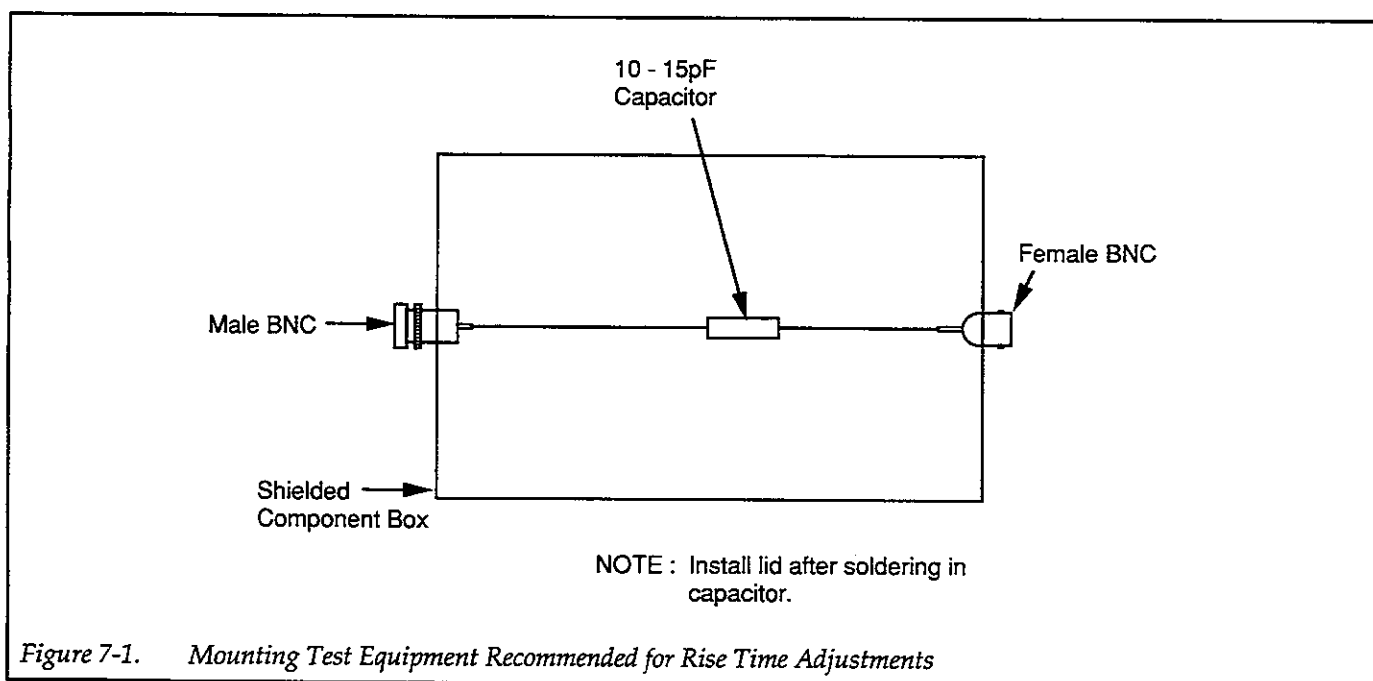

Figure 7-1. Mounting Test Equipment Recommended for Rise Time Adjustments

7.5.2 Environmental Conditions

All adjustments should be performed at an ambient temperature of 18°C-28°C and at a relative humidity of less than 70%.

7.5.3 Initial Conditions

The Model 428 should be turned and allowed to warm up for at least one hour before performing any adjustments. The test equipment should also be allowed to warm up for the minimum period recommended by the manufacturer.

7.5.4 Adjustment Locations

Figure 7-2 shows the location of the various adjustments. In order to gain access to these adjustments, you must first remove the case cover as follows:

1. Remove the rear bezel and screws that secure the case cover to the chassis.
2. Slide the cover to the rear to remove it.
3. For the rise time adjustments only, remove the access door in the analog shield.

WARNING

Lethal voltages may be present on shields and components.

7.5.5 Output Offset Adjustment

1. Turn on the DMM, and set it up as follows:

Resolution: maximum
Function: DCV
Range: 300mV
Zero: off

2. Turn on the Model 428 and set the unit up as follows:

Gain: 10^3 V/A
Voltage bias: off
Current suppress: off
Filter: off
Zero check: off

3. Install the protection cap on the INPUT connector.
4. Temporarily short the DMM VOLTS input, then enable zero after the reading settles. Remove the short, and leave zero enabled for the remainder of the test.
5. Connect the DMM to the Model 428, as shown in Figure 7-3, then allow the reading to settle.
6. Press SHIFT CORRECT to zero correct the instrument.
7. Adjust R158 (output offset adjustment) for a reading of $< \pm 400 \mu\text{V}$.

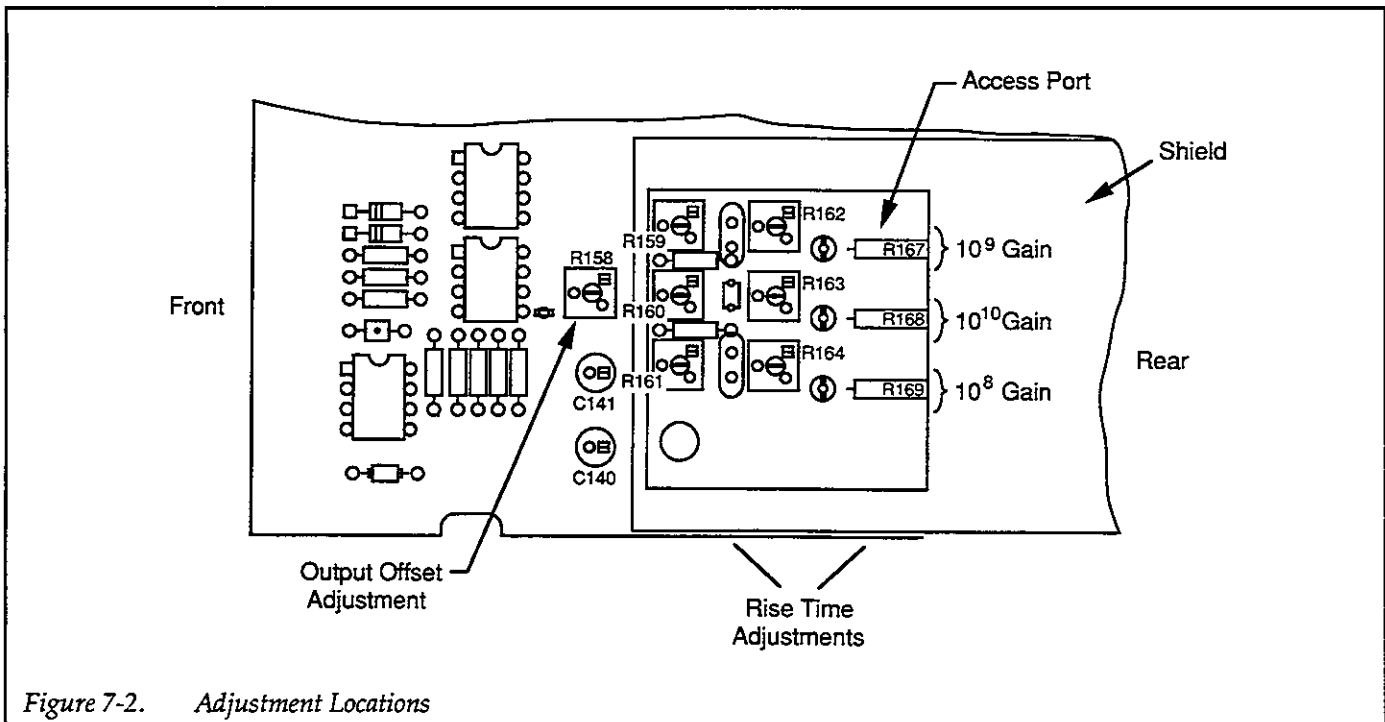

Figure 7-2. Adjustment Locations

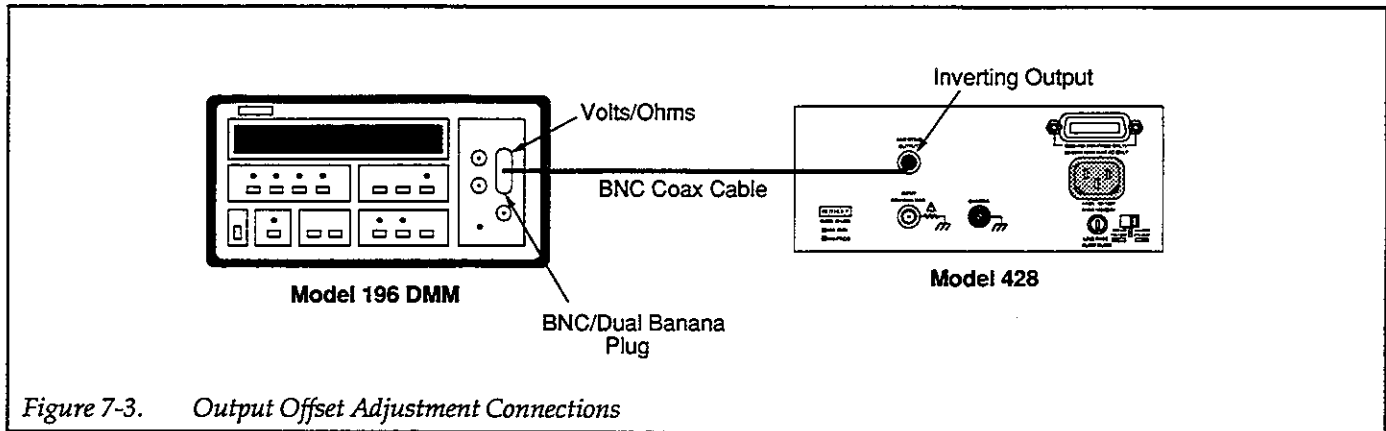

Figure 7-3. Output Offset Adjustment Connections

7.5.6 Rise Time Adjustments

NOTE

The rise time adjustments need be performed only if R167, R168, or R169 has been replaced or if improper rise time performance on the 10^8 - 10^{10} gain ranges is noted. In order to move the resistor, it will be necessary to heat the soldered lead with a soldering iron unless the resistor was just replaced.

1. Connect the function generator, test capacitor box, and oscilloscope to the Model 428, as shown in Figure 7-4.
2. Set up the Model 428 as follows:
Gain: 10^8 V/A
Voltage bias: off
Current suppress: off
Filter: off
Zero check: off
3. Set potentiometers R162, R163, and R164 fully counterclockwise.
4. Set potentiometers R159, R160, and R161 fully clockwise.

NOTE

Perform step 5 only for newly-installed R167, R168, and R169. Otherwise, go on to step 6.

5. Slide R167, R168, and R169 towards the rear panel as far as they will go.

NOTE

Do not touch the resistor bodies with your hands because possible contamination may degrade unit performance.

6. Set the function generator for a triangular waveform with a fundamental frequency of 235Hz, and a peak-to-peak amplitude of 10V.
7. Set the oscilloscope controls to view one or two cycles of the output waveform at a convenient amplitude.
8. Slide R169 for maximum flatness of the output waveform, as shown in Figure 7-5.

NOTE

It may be possible to adjust for proper rise time without sliding R167, R168, and R169.

9. Adjust R164 and then R161 alternately for a rise time (10%-90%) of $<40\mu\text{sec}$. Adjust these potentiometers as little as possible, and make sure the output waveform has no peaks, ripples, or overshoot, only square or slightly-rounded edges (see Figure 7-5).
10. Repeat steps 6 through 8 for 10^9 V/A and 10^{10} V/A gain using the settings and adjustments summarized in Table 7-4.

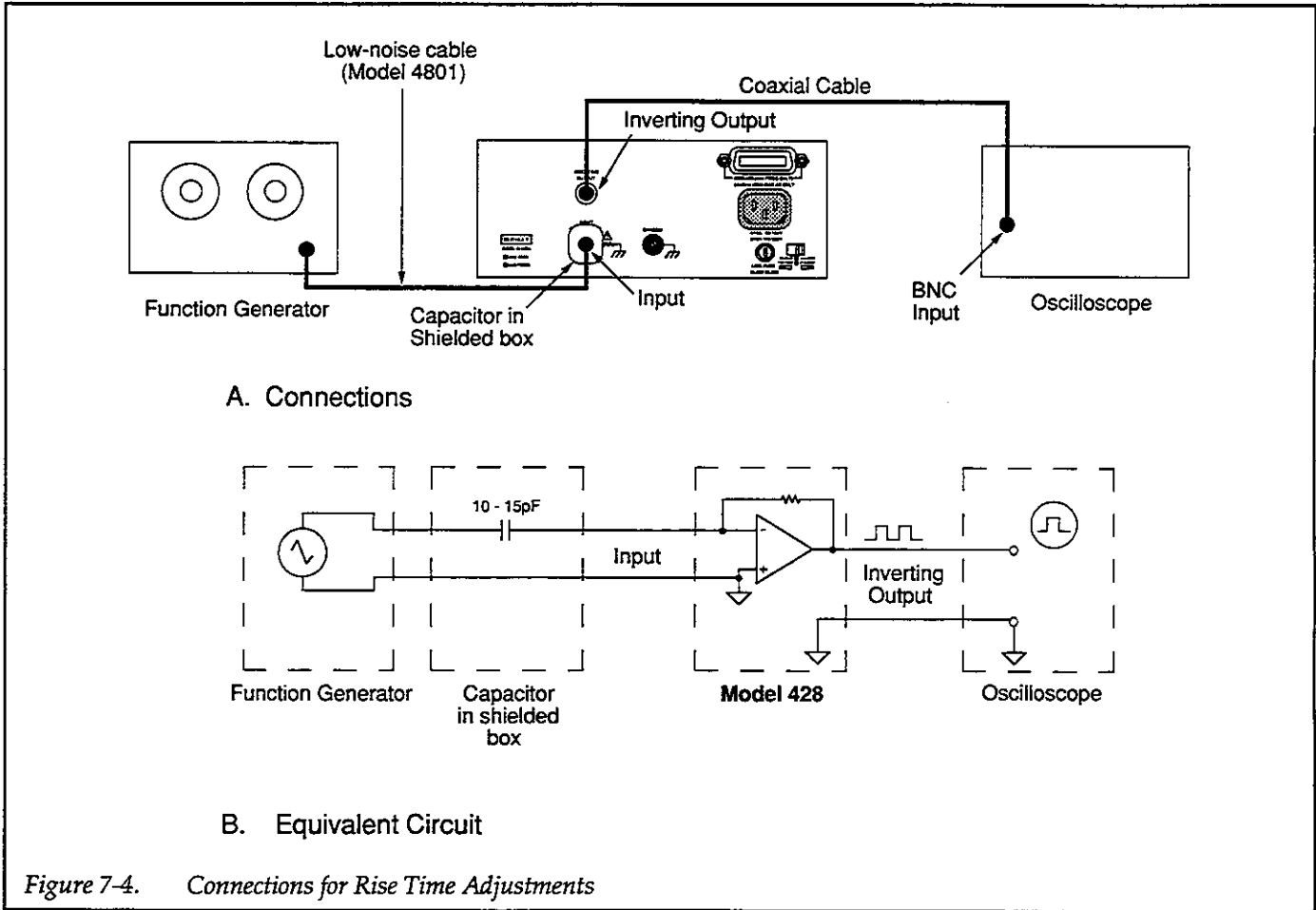

Figure 7-4. Connections for Rise Time Adjustments

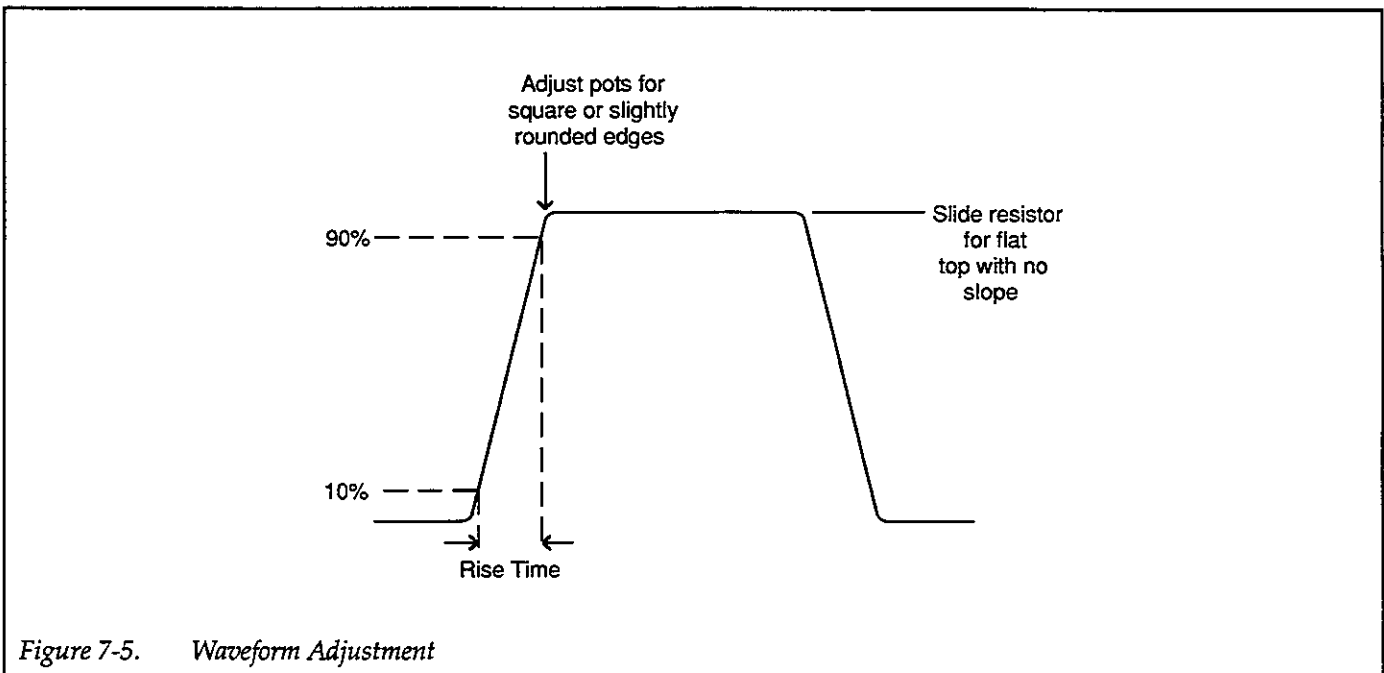

Figure 7-5. Waveform Adjustment

Table 7-4. Rise Time Adjustment Parameters

Gain (V/A)	Generator Output (V_{pp})	Slide Resistor	Adjust Potentiometer	Rise Time (10-90%, μ sec)
10^8	10	R169	R164, R161	<40
10^9	1	R167	R159, R162	<100
10^{10}	0.1	R168	R160, R163	<250

7.6 DISASSEMBLY

The following paragraphs outline the basic procedures for disassembling the Model 428. In general, the procedures should be carried out in the order presented here. Figure 7-6 shows an exploded view of the instrument that can be used as an aid in disassembling and reassembling the unit.

7.6.1 Cover Removal

First remove the handle by rotating the handle until the arrows on the handle line up with the arrows on the mounting ears, then pull out on the handle ends to remove. Remove the mounting ear screws and mounting ears.

To remove the cover, remove the rear bezel, then simply remove the bottom screw that secures the cover to the chassis, and slide the cover off the chassis to the rear.

WARNING

Disconnect the line cord and all other instruments from the Model 428 before removing the case cover.

To install the cover, slide the cover over the chassis until the front edge is flush with the front panel, then install the bottom screw to secure the cover. Install the rear bezel and secure it.

WARNING

The screw that secures the cover to the chassis must be installed and secured to assure protection against a possible shock hazard.

7.6.2 Shield Removal

The top and bottom analog shields can be removed as follows:

NOTE

Be careful not to touch critical high-impedance areas of the mother board with your hands after the shields are removed.

1. Remove the four screws that secure the two shields to the mother board.
2. Remove the bottom shield, and set it aside.
3. Carefully guide the top shield forward until it is clear of the rear panel INVERTING OUTPUT connector, then remove the shield completely.
4. Make sure the gaskets on the long edges of both shields are in place when installing the shields.

7.6.3 Front Panel Removal

Remove the front panel as follows:

1. Disconnect the display board ribbon cable from the digital board.
2. Pry the front panel tabs out away from the side panels slightly until the tabs clear the side mounting screw shoulders. As you pry each tab clear, push forward on the front panel so that the tab does not slip back into place.
3. Once all four tabs are clear, slide the front panel forward until it is clear of the chassis. Guide the cable plug through the slot.
4. To remove the display board, remove the knob, then remove the circuit board from the front panel by pressing in on the retaining clips.
5. Reverse the above procedure to install the front panel. Be sure to install the knob after securing the display board to the front panel.

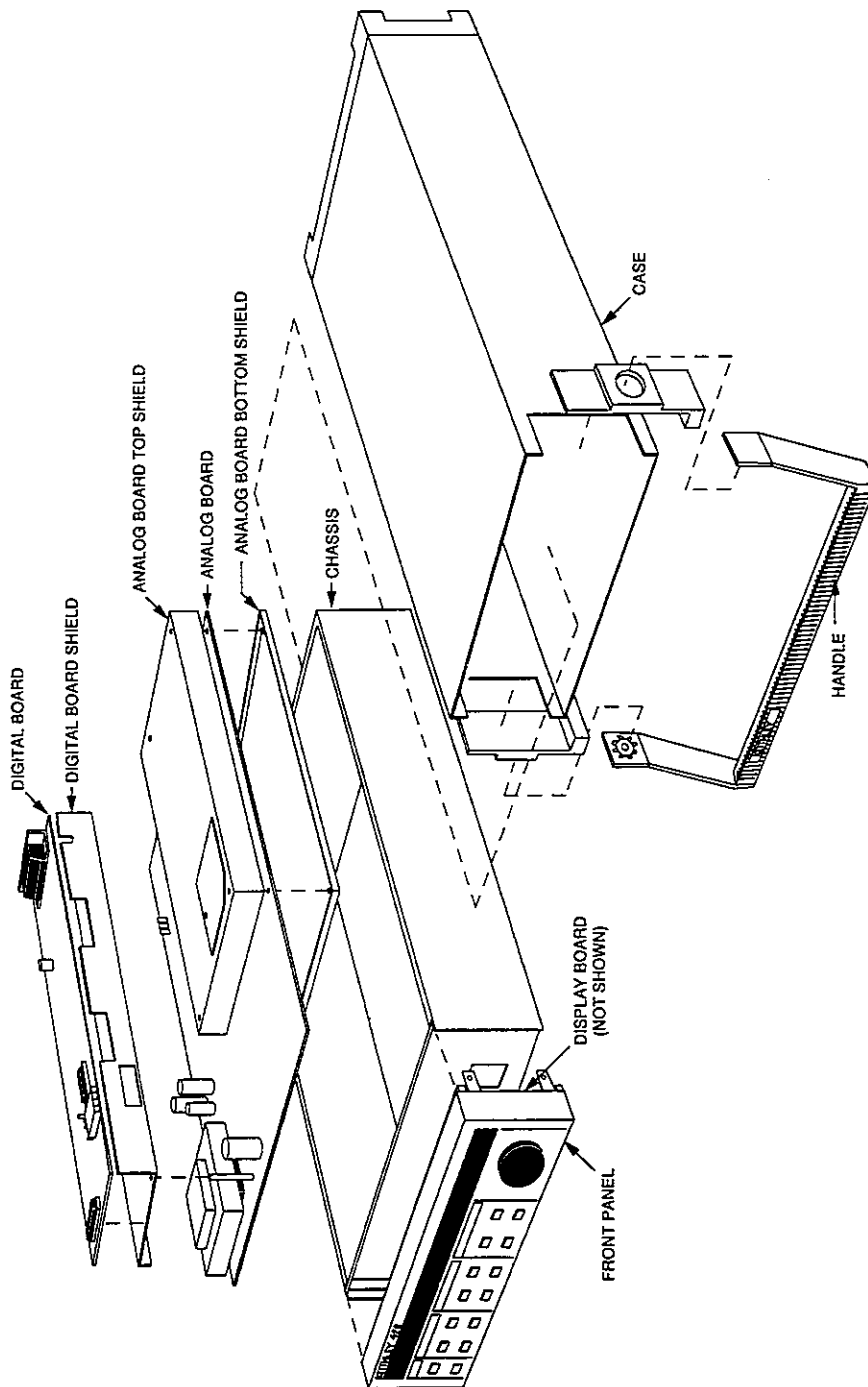

Figure 7-6. Model 428 Exploded View

7.6.4 Circuit Board Removal

Digital Board Removal

Remove the digital board as follows:

1. Disconnect the ribbon cables and power supply plug from the digital board.
2. Remove the screws that secure the IEEE-488 connector (428-PROG) or rear of the digital board (428-MAN) to the rear panel.
3. Remove the screws that secure the digital board to the digital shield, then remove the board by sliding the board forward until the slots clear the side tabs. Pull the board free of the shield.

Mother Board Removal

1. Remove the screw that secures the digital board shield to the analog board. Remove the shield.
2. Note the positions of the input and output connections, then unplug the input and output connecting cables from the mother board.
3. Remove the screw that secures the mother board to the front of the chassis.
4. Slide the mother board forward so the slots clear the side tabs.
5. Swivel the mother board away from the chassis, pivoting on the long edge near the power entry module. Unplug the power module connector, and remove the board.

7.7 TROUBLESHOOTING

7.7.1 Recommended Troubleshooting Equipment

Table 7-5 summarizes recommended troubleshooting equipment.

7.7.2 Self-test

The self-test performs tests on the front panel LEDs, as well as the RAM and ROM ICs within the instrument. Perform the self-test as follows:

Table 7-5. Recommended Troubleshooting Equipment

Description	Application
Keithley Model 199 DMM	Measure AC and DC voltages, resistors
Keithley Model 263 Calibrator	Apply signal currents to input
20MHz oscilloscope	View digital signals, logic level

1. Press MENU five times (four times for a Model 428-MAN) to display the following:

SELFTEST N

2. To run the self-test, use the knob or cursor keys to display the following:

SELFTEST Y

3. Press MENU to begin the self-test. The unit will then test the display segments and digits in sequence and then return to normal display if the RAM and ROM ICs pass the tests.
4. If a RAM or ROM error occurs during the self-test, the unit will display one of the following messages:

RAM ERROR

or,

ROM ERROR

In this instance, you must press a front panel key to return to normal display.

7.7.3 Troubleshooting Procedures

Table 7-6 through Table 7-11 summarize the troubleshooting procedures for the various circuits within the instrument. In general, the procedures should be performed in the order given, with the power supplies being checked first, the digital board second, and so on. Figure 7-7 shows the various test points for the troubleshooting procedures.

WARNING

Lethal voltages may be present on components and shields.

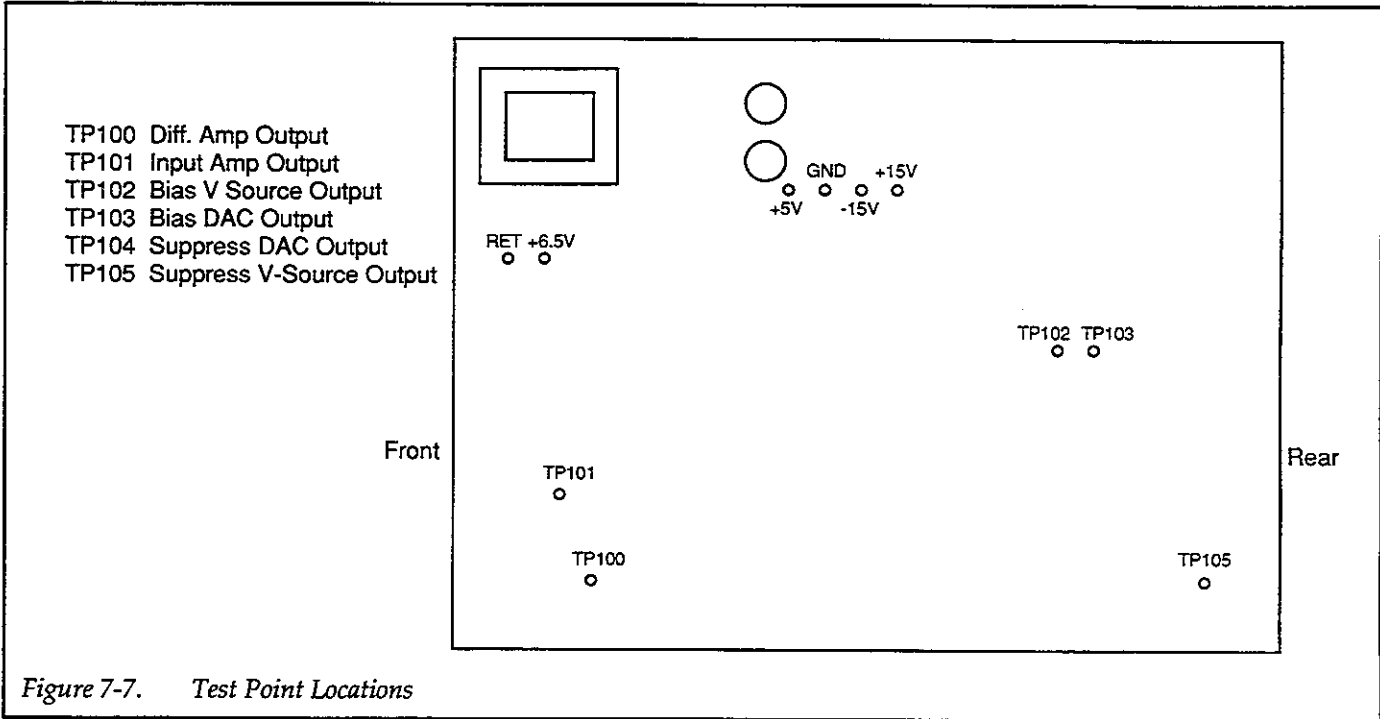

Figure 7-7. Test Point Locations

Table 7-6. Power Supply Checks

Step	Item/Component	Required Condition	Description
1	S100 line voltage switch	Set to 115 or 230V as required	Line voltage selection
2	F100 line fuse	Check continuity	Remove to check
3	Line power	Plugged into live receptacle, power on	
4	+5V supply +5V pad	+5V, ±5%	Referenced to GND pad
5	+15V supply, +15V pad	+15V, ±5%	Referenced to GND pad
6	-15V supply, -15V pad	-15V, ±5%	Referenced to GND pad
7	+6.6V supply, +6.5V pad	+6.5V, ±20%	Referenced to GND pad

Table 7-7. Digital Circuitry Checks

Step	Item/Component	Required Condition	Remarks
1	Power on self-test	No failures reported	RAM ERROR: check U511 ROM ERROR: check U508 NO DFLTS: check U510
2	U500, pin 3	+5V, ±5%	+5V digital supply, referenced to digital common (U500, pin 2)
3	U509, pins 34 & 35	2MHz square wave	Bus E and Q clocks
4	U509, pin 3	25µsec negative-going pulse every 1msec	MPU IRQ line
5	U509, pin 37	Stays low briefly on power up, then goes high at power-up	MPU RESET line
6	U501, pin 18	Brief pulses when gain is changed	ANALOG CLOCK
7	U501, pin 14	Brief pulses when gain is changed	ANALOG DATA
8	U501, pin 9	Brief pulses when gain is changed	ANALOG STROBE
9	U502, pin 9	2MHz 8-pulse burst at 5µsec intervals	DISPLAY CLOCK
10	U501, pin 3	Pulse burst every 1msec	DISPLAY DATA
11	U501, pin 7	Positive pulse every 1msec	DISPLAY LEFT signal
12	U504, pin 4	Pulse train with CURRENT SUPPRESS pressed	KEY S0 data
13	U504, pin 5	Pulse train with GAIN pressed	KEY S1 data
14	U545, pin 6	Pulse train with FILTER pressed	KEY S2 data
15	U503, pin 6	Negative-going pulse every 1msec	SHIFT DONE signal
16	U504, pins 2 & 3	Alternates between high and low every other knob click	Knob data
17	U503, pin 13	High with OVERLOAD, low with no overload	Overload detect
18	U502, pin 2	Alternates between high and low during auto suppress	Zero crossing detect signal
19	U515, pin 8	Goes low when bus command is sent	IEEE-488 ATN line
20	U515, pins 4, 5, 6	Refer to Figure E-2 for required conditions	Handshake sequence for NDAC, NRFD, and DAV

Table 7-8. Analog Circuitry Checks

Step	Item/Component	Required Condition	Remarks																
1	Front panel controls	GAIN = 10 ³ FILTER off CURRENT SUPPRESS off VOLTAGE BIAS off GAIN X10 off ZERO CHECK off	Initial conditions																
2	Reference point	Connect DMM LO or scope LO to analog common (INPUT LO)	All voltages referenced to analog common																
3	Zero correct	Press SHIFT CORRECT	Zero correct unit																
4	INPUT connector	Apply 0.000mA input																	
5	TP101	0V ±10mV	Input amplifier output																
6	TP100	0V ±10mV	Differential amplifier output																
7	ANALOG OUTPUT	0V ±10mV	Instrument output																
8	INPUT connector	Apply +5.000mA	Positive current input																
9	TP101	-5V	Input amplifier output																
10	TP100	-5V	Differential amplifier output																
11	ANALOG OUTPUT	-5V	Instrument output																
12	INPUT connector	Apply -5.000mA	Negative current input																
13	TP101	+5V	Input amplifier output																
14	TP100	+5V	Differential amplifier output																
15	ANALOG OUTPUT	+5V	Instrument output																
16	Repeat steps 8-15 for listed gains and currents	<table border="1"> <thead> <tr> <th>GAIN</th> <th>Input</th> </tr> </thead> <tbody> <tr> <td>10⁴</td> <td>±500μA</td> </tr> <tr> <td>10⁵</td> <td>±50μA</td> </tr> <tr> <td>10⁶</td> <td>±5μA</td> </tr> <tr> <td>10⁷</td> <td>±500nA</td> </tr> <tr> <td>10⁸</td> <td>±50nA</td> </tr> <tr> <td>10⁹</td> <td>±5nA</td> </tr> <tr> <td>10¹⁰</td> <td>±500pA</td> </tr> </tbody> </table>	GAIN	Input	10 ⁴	±500μA	10 ⁵	±50μA	10 ⁶	±5μA	10 ⁷	±500nA	10 ⁸	±50nA	10 ⁹	±5nA	10 ¹⁰	±500pA	All measured voltages should be -5V or +5V
GAIN	Input																		
10 ⁴	±500μA																		
10 ⁵	±50μA																		
10 ⁶	±5μA																		
10 ⁷	±500nA																		
10 ⁸	±50nA																		
10 ⁹	±5nA																		
10 ¹⁰	±500pA																		

Table 7-9. Comparator Checks

Step	Item/Component	Required Condition	Remarks
1	Front panel controls	GAIN = 10 ³ FILTER off CURRENT SUPPRESS off VOLTAGE BIAS off GAIN X10 off ZERO CHECK off	Initial conditions
2	U113, pins 2 & 3	≈0V	Both inputs should be the same +15V supply -15V supply Zero crossing signal
3	U113, pin 7	+15V	
4	U113, pin 4	-15V	
5	U113, pin 6	Alternate between -13.75V and +13.75V during zero correct	
6	INPUT jack	Apply +5.000mA	
7	U119, pins 2 & 3	-5V	Signal input to window comparator Comparator positive reference Comparator negative reference No overload output Overload input signal Overload output No overload negative input No overload output Overload negative input Overload output
8	U119, pin 6	≈+10.6V	
9	U119, pin 3	≈-10.6V	
10	CR112 or CR113 cathode	-0.3V	
11	INPUT connector	Apply +11mA	
12	CR112 or CR113 cathode	≈+13V	
13	INPUT connector	Apply -11mA	
14	CR112 or CR113 cathode	≈-0.3V	
15	INPUT connector	Apply -11mA	
16	CR112 or CR113 cathode	≈+13V	

Table 7-10. Suppress Circuit Checks

Step	Item/Component	Required Condition	Remarks
1	SETUP SUPPRESS	Program 0.000mA value	Initial suppression value
2	SUPPRESS ENABLE	Enable suppression	
3	U129, pin 1	+5V	Suppress DAC reference Suppress DAC output Suppress source output
4	TP104	-2.5V	
5	TP105	0V	
6	SETUP SUPPRESS	Program +5.000mA value	
7	TP104	-4.02V	Suppress DAC output Suppress source output
8	TP105	+5V	
9	SETUP SUPPRESS	Program -5.000mA value	
10	TP104	-0.98V	Suppress DAC output Suppress source output
11	TP105	-5V	

Table 7-11. Voltage Bias Circuit Checks

Step	Item/Component	Required Condition	Remarks
1	SETUP VOLTAGE BIAS	Program 0.000V bias	Initial bias value
2	ENABLE VOLTAGE BIAS	Enable voltage bias	
3	U126, pin 19	+5V	Bias DAC reference
4	TP103	-2.5V	Bias DAC output
5	TP102	0V	Bias source output
6	U125, pin 1	0V	Suppression bias compensation
7	SETUP VOLTAGE BIAS	Program +5.000V bias	
8	TP103	-5V	Bias DAC output
9	TP102	+5V	Bias source output
10	U125, pin 1	-5V	Suppression bias compensation
11	SETUP VOLTAGE BIAS	Program -5.000V bias	
12	TP103	0V	Bias DAC output
13	TP102	-5V	Bias source output
14	U125, pin 1	+5V	Suppression bias compensation

7.8 10⁸ – 10¹⁰ GAIN RESISTOR REPLACEMENT

The 10⁸-10¹⁰ gain resistors (R167, R168, and R169) should not normally require replacement. The procedure below outlines the basic replacement procedure for replacing these resistors, which can be obtained directly from Keithley Instruments, Inc. (see parts list).

NOTE

Because of the difficulty of the repair, it is recommended that the Model 428 be returned to the Keithley Instruments service department for 10⁸-10¹⁰ gain resistor replacement. The rise time adjustments discussed in paragraph 7.5 must be performed after replacing the 10⁸-10¹⁰ gain resistors.

1. Remove the case cover and analog shields, as discussed in paragraph 7.6.

WARNING

Disconnect the Model 428 from line power and from other instruments before removing the top cover.

NOTE

Do not touch the high-impedance areas of the mother board or the bodies of the replacement

resistors with your hands to avoid contamination that could degrade performance.

2. Cut out the old high-gain resistors, leaving enough lead length to grasp with needlenose pliers. After cutting, carefully guide each resistor body through the hole in the resistor shield board.
3. Unsolder the resistor lead slide terminals from the Teflon® terminals, taking care not to damage the terminals. After removing slide terminals, carefully clean excess solder from the Teflon® terminals with a de-soldering tool or solder wick.
4. Place a replacement slide terminal on both leads of each replacement resistor. The boss on the slide terminals should be oriented closest to the resistor body (see Figure 7-8).
5. Guide the replacement resistor through the hole in the shield board, then seat each slide terminal in the appropriate Teflon® terminal.

NOTE

Be sure to install each resistor in the correct position. Resistor positions are shown in Figure 7-2 (R167=1GΩ, R168=10GΩ, R169=100MΩ).

6. After all replacement resistors are installed, solder the slide terminals to the Teflon® terminals. Be careful not to solder the resistor leads to the slide terminals because the resistor must be free to slide to adjust rise time.

7. Carefully clean the Teflon® insulators and surrounding board areas free of solder flux and other contaminants using Freon® TE or TMS or the equivalent. After cleaning, swab the cleaned area with a soft brush dipped in clean methanol, then allow the area to dry for several hours in a 50°C low-humidity before performing the rise time adjustments.
8. Install the top and bottom analog shields.
9. Perform the rise time adjustments summarized in paragraph 7.5.

NOTE

Rise time adjustments must be performed with the analog shield on the analog board in place.

10. After the rise time adjustments have been completed, solder one lead of each resistor to its slide terminal (solder the end that will be accessible through the access port). Clean the insulator as in step 7.
11. Install the case cover when the adjustments have been completed.

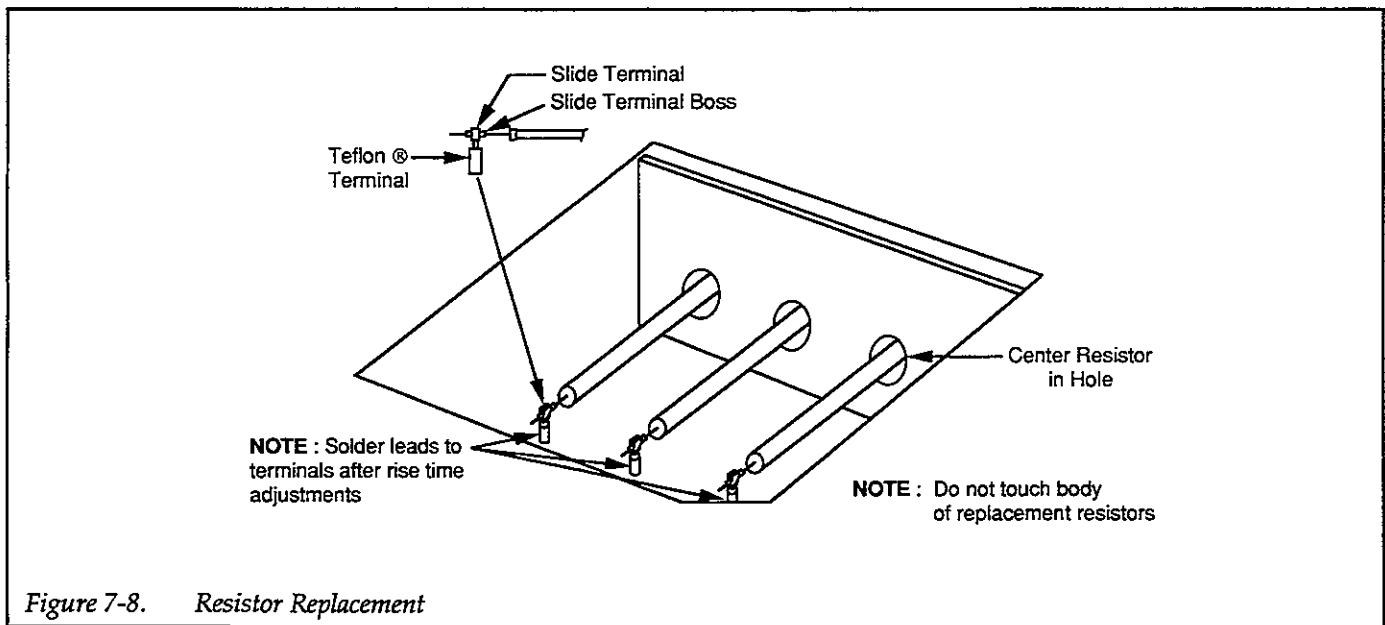

Figure 7-8. Resistor Replacement

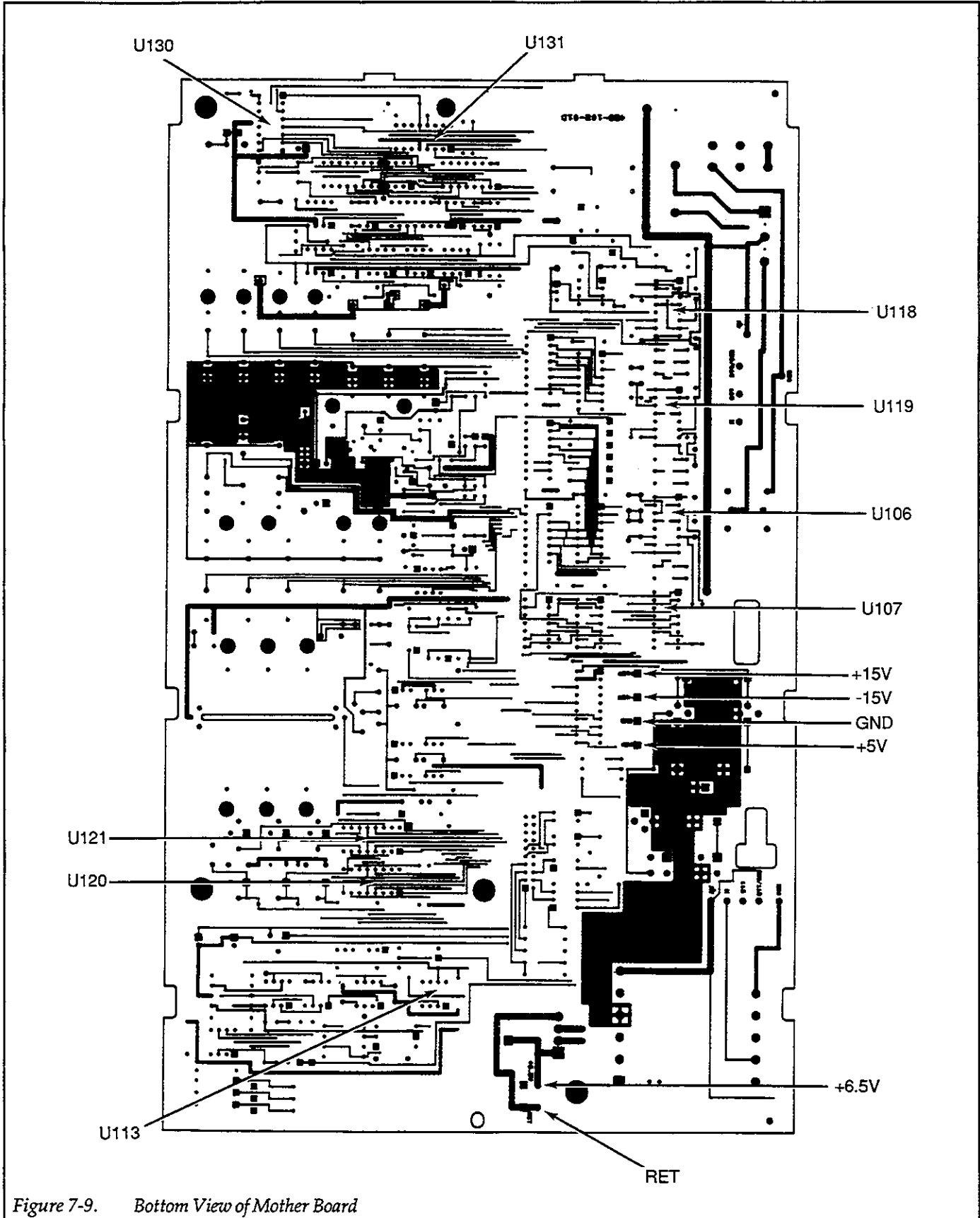

Figure 7-9. Bottom View of Mother Board

SECTION 8

Replaceable Parts

8.1 INTRODUCTION

This section contains replacement parts information, schematic diagrams, and component layout drawings for the Model 428 Current Amplifier.

8.2 PARTS LISTS

Parts lists for the various circuit boards are included in tables integrated with schematic diagrams and component layout drawings for the boards. Parts are listed alphabetically in order of circuit designation.

8.3 ORDERING INFORMATION

Keithley Instruments, Inc. maintains a complete inventory of all normal replacement parts. To order a part, or to obtain information concerning parts, contact your Keithley representative or the factory. When ordering parts, include the following information:

- Instrument model number

- Instrument serial number
- Part description
- Circuit designation, where applicable
- Keithley part number

8.4 FACTORY SERVICE

If the Model 428 is to be returned to the factory for service, carefully pack the unit, and include the following:

- Complete the service form at the back of this manual, and return it with the instrument.
- Advise as to the warranty status of the instrument.
- Write the following on the shipping label: ATTENTION REPAIR DEPARTMENT.

8.5 COMPONENT LAYOUTS AND SCHEMATIC DIAGRAMS

Component layout drawings and schematic diagrams are included on the following pages integrated with the parts lists.

Model 428 Analog Board, Parts List

Circuit Desig.	Description	Keithley Part No.
AT100,AT101, AT103,AT104 AT102	IC,PHOTO COUPLER,PS2501A-1 IC,DUAL HIGH CMR/SPEED OPTO,HCPL-2631	IC-670 IC-588
C103 C104,C105,C109,C140, C141,C163,C170 C106,C108 C107 C110 C113,C132 C117 C118 C123 C124 C127,C169 C129,C130,C164,C166, C167 C131 C134 C135,C160 C145 C146 C147 C148,C154 C149 C150,C151,C155..C157 C152 C153 C159 C165 C168 C179 C200..C237	CAP,1500UF,-20,+100%,25V,ALUM ELEC CAP, 10UF,-20+100%,25V,ALUM ELEC CAP,2200,20%,35V,ALUM ELECTROLY CAP,10,000UF,-20+100%,16V ALUMINUM CAP,.68UF,5%,63V,POLYESTER CAP,.068UF,5%,100V,POLYESTER CAP,680P,5%,100V,POLYESTER CAP,1UF,5%,63V,POLYESTER CAP,68PF,10%,1000V,CERAMIC CAPACITOR, METALLIZED POLYESTER CAP,.047UF,20%,250V,METALIZED POLYESTER CAP,1UF,20%,50V, CERAMIC CAPACITOR, METALLIZED POLYESTER CAP,.1UF,5%,63V,POLYESTER CAP,150PF,10%,1000V,CERAMIC CAP,680PF,10%,1000V,CERAMIC CAP,2200PF,10%,1000V,CERAMIC CAP,.033UF,10%,100V,EPOXY CAP,2.2PF,.5%,1000V,CERAMIC CAP,220P,10%,1000V CERAMIC CAP,10PF,10%,1000V,CERAMIC CAP,33PF,10%,1000V,CERAMIC CAP,5PF,10%,1000V,CERAMIC CAP,1.5PF,.25% TOL, 1000V, CERAMIC CAP,100PF,10%,1000V,CERAMIC CAP,.01UF,20%,50V,CERAMIC CAP,4.7UF,-20+100%,25V,ALUM ELEC CAP,.1UF,20%,50V,CERAMIC	C-314-1500 C-314-10 C-428-2200 C-313-10000 C-423-.68 C-424-.068 C-426-680P C-423-1 C-64-68P C-424-1000P C-178-.047 C-237-1 C-424-6800P C-423-.1 C-64-150P C-64-680P C-64-2200P C-371-.033 C-308-2.2P C-64-220P C-64-10P C-64-33P C-64-5P C-367-1.5P C-64-100P C-365-.01 C-314-4.7 C-365-.1
CR100 CR101,CR102 CR103..105,109..113, 115..117,121..125 CR114 CR118,CR119 CR120	DIODE, BRIDGE PE05 DIODE,SILICON,W04M (CASE WM) DIODE,SILICON,IN4148 (DO-35) DIODE,BRIDGE,VM18 DIODE,SILICON,IN4006 (D0-41) DIODE, DUAL LOW LEAKAGE, 1D101	RF-48 RF-46 RF-28 RF-52 RF-38 DN-3
F101	FUSE, .4A,250V,3AG,SLO-BLO (90-125V) .2A, 250V, 3AG, SLO-BLO (180-250V)	FU-92 FU-93
J1002 J1011 J1012 J1013	CONN,MALE,5 PIN TERMINAL,TEFLON CONN,BERG,1 PIN LATCHING HEADER,FRICTON, SGL ROW	CS-288-5 TE-113 CS-339-1 CS-724-3

K100..K103	RELAY (SPST),GORDOS,4705S	RL-131
K104..K118	RELAY (SPST)	RL-70
P1005	CABLE ASSEMBLY, 20 CONDUCTOR	CA-27-9B
P1006	CONNECTOR, HOUSING	CS-716-4
Q102	TRANS, N CHANNEL JFET,PN5434(TO-92)	TG-174-1
Q103	TRANS,N CHANNEL JFET,2N4393	TG-169
Q104,Q105	TRANS,CURRENT REGULATOR,CR120	TG-159
Q106	TRANS,SELECTED N CHANNEL JFET,2N4392	TG-77-1
Q107	TRANS,N CHANNEL FET,5452 (T0-71)	TG-70
Q108	TRANS,NPN SILICON,2N3904 (T0-92)	TG-47
R106,R107,R109,R179, R194,R212	RES,1K,5%,1/4W,COMPOSITION OR FILM	R-76-1K
R108	RES,390,5%,1/4W,COMPOSITION OR FILM	R-76-390
R110,R112,R129	RES,10M,5%,1/4W,COMPOSITION OR FILM	R-76-10M
R111,R113,176	RES,1.5K,5%,1/4W,COMPOSITION OR FILM	R-76-1.5K
R116..R118	RES,330,5%,1/4W,COMPOSITION OR FILM	R-76-330
R119,R120	RES,820,5%,1/4W,COMPOSITION OR FILM	R-76-820
R121,R190	RES,100,5%,1/4W,COMPOSITION OR FILM	R-76-100
R122,R123,R133,R144.. R146,R174,178,180	RES,10,5%,1/4W,COMPOSITION OR FILM	R-76-10
R124	RES,1M,5%,1/4W, COMPOSITION OR FILM	R-76-1M
R125,R135	RES,1.5K,.5%,3/4W, FIXED METAL FILM	R-303-1.5K
R126,R198	RES,1K,.1%,1/10W,METAL FILM	R-263-1K
R127,R128	RES,4.5K,.1%,1/10W,METAL FILM	R-263-4.5K
R130,R134	RES,82.5K,1%,1/8W,METAL FILM	R-88-82.5K
R132,R139	RES,4.12K,1%,1/8W,METAL FILM	R-88-4.12K
R136,R204,R207,R208	RES NET,10K,.5%,.150W	TF-220-10K
R137,R141	RES,15K,5%,1/4W,COMPOSITION OR FILM	R-76-15K
R138,R151	RES,8.25K,1%,1/8W,METAL FILM	R-88-8.25K
R140	RES,30K,5%,1/4W,COMPOSITION OR FILM	R-76-30K
R143	RES,4.7K,5%,1/4W,COMPOSITION OR FILM	R-76-4.7K
R148	RES,47,5%,1/4W,COMPOSITION OR FILM	R-76-47
R150,R152	RES,28.7K,1%,1/8W,METAL FILM	R-88-28.7K
R153	RES, 1K,1%,1/2W FUSIBLE METAL FILM	R-370-1K
R158	POT,50K,10%,.5W,NON-WIREWOUND	RP-97-50K
R159..R164	POT,10K,10%,.5W,NON-WIREWOUND	RP-97-10K
R166	RES,1K,.1%,1/8W, METAL FILM	R-176-1K
R167,R205	RES,1G,2%,1.5W,HY MEG	R-289-1G
R168	RES,10G,2%,1.5W,HY MEG	R-289-10G
R169,R206	RES,100M,1%,1.5W,HY MEG	R-289-100M
R170	RES,10.1K,.1%,1/2W,METAL FILM	R-169-10.1K
R171,R203	RES,10M,.25%,1/8W,FIXED METAL FILM	R-305-10M
R172	RES,111K,.1%,1/2W METAL FILM	R-169-111K
R173	RES,1M,.1%,1/8W, METAL FILM	R-176-1M
R175	RES,100K,5%,1/4W,COMPOSITION OR FILM	R-76-100K
R181,R182	RES,20K,.1%,1/10W,METAL FILM	R-263-20K
R183	RES,360,5%,1/4W,COMPOSITION OR FILM	R-76-360
R185,R211	RES,47K,5%,1/4W,COMPOSITION OR FILM	R-76-47K
R186	RES,18,1%,1/2W,FUSIBLE METAL FILM	R-370-18
R187,R188	RES,1.2K,5%,1/4W,COMPOSITION OR FILM	R-76-1.2K
R191	RES,20K,5%,1/4W,COMPOSITION OR FILM	R-76-20K
R192	RES,3.65K,1%,1/8W,METAL FILM	R-88-3.65K
R193,R196,R213	RES,10K,1%,1/8W,METAL FILM	R-88-10K
R197	RES,1M,.1%,1/8W, METAL FILM	R-176-1M
R200	RES,240,5%,1/4W,COMPOSITION OR FILM	R-76-240
R201	RES,100K,.1%,1/10W,METAL FILM	R-263-100K

R202	RES,10K,.1%,1/2,METAL FILM	R-169-10K
R215,R218,R219,R222- R226	RES,10K,5%,1/4W,COMPOSITION OR FILM	R-76-10K
R216		R-76-30
R217, R220, R221		R-76-100K
R227,228	RES,6.383K, .1%,1/10W METAL FILM	R-263-6.383K
S100	SWITCH,SLIDE (DPDT)	SW-476
S101	SWITCH,PUSHBUTTON (6 POLE)	SW-466
T100	TRANSFORMER (90-250V)	TR-284A
TE100..TE105	TERMINAL (TEFLON)	TE-112
TE106..TE110,TE112..120	TERMINAL (TEFLON)	TE-97-1
TP100..TP105	CONN,TEST POINT	CS-553
U100	IC,OCTAL TRI STATE BUFFER,74HCT240	IC-683
U101	IC,QUAD 2 INPUT AND GATE,74HCT08	IC-550
U102	IC,8 BIT PAR OUT SHIFT REG,74HCT164	IC-456
U103	IC,POS VOLTAGE REG +15V,500MA,7815	IC-194
U104	IC,NEG VOLTAGE REG -15V,500MA,79M15	IC-195
U105	IC,+5V VOLTAGE REGULATOR, 7805	IC-93
U106,U115,U118,U120, U121,U131	IC,SPST CMOS ANALOG SWITCH, (DG411)	IC-667
U107..U109,U128,U130	IC,8 STAGE SHIFT/STORE REGISTER,4094	IC-251
U110..U112	IC,DARLINGTON ARRAY,2003	IC-206
U113,U116,U117,U122	IC,JFET OP-AMP,LF411	IC-453
U114	IC,DUAL BIFET OP-AMP,AD712	IC-668
U119	IC,DUAL JFET OP-AMP,412	IC-504
U123,U125	IC,DUAL JFET OP-AMP,LT1013	IC-423
U124	IC,+5V VOLTAGE REGULATOR, LT1021-5	IC-669
U126	IC,12-BIT CMOS D/A CONVERTER,AD7545	IC-673
U127	IC,20V OP-AMP,1012	IC-394
U129	IC,14-BIT CMOS D/A CONVERT,AD7538KN	IC-601
VR100..103	DIODE, ZENER, 12V,IN9638	DZ-54

001-BZP

LTR. ECO NO.	REVISION	ENG.	DATE
B	REVISED	MS	11/22/66
C	REVISED	MS	12/19/66
D	REVISED	MS	1/22/67
E	REVISED	MS	2/20/67
F	CHG-D NETWORK FROM REU E TO F	MS	1/16/67
G	REU D NETWORK FROM REU E TO F	MS	1/16/67
H	CHG-D NETWORK FROM REU E TO F	MS	1/22/67
I	CHG-D NETWORK FROM REU E TO F	MS	2/21/67
J	CHG-D 0104 & 0105 PACKAGE	MS	2/11/67

NOTE: TRANSFORMER WIRING SHOWN IN THE 110/220VAC POSITION. SWITCH BLK/RED & YEL/BLU WIRES INTO BOARD FOR 100/200VAC.

*B-32x1-1/2" PPH
WA-4B WASHER

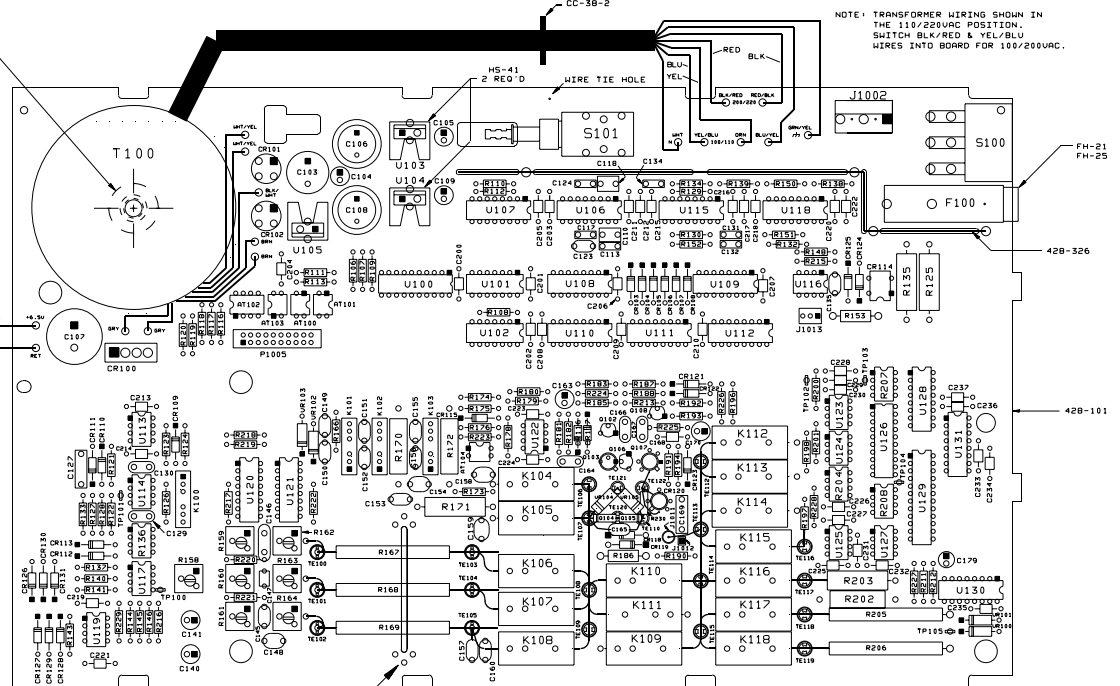

SC-71
#18 AWG RED
#18 AWG BLK
P1006 TO DIGITAL BOARD

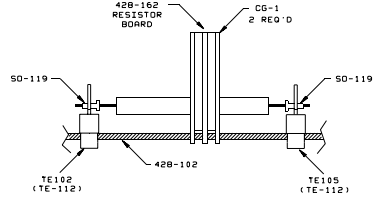

DETAIL "A"
SIDE VIEW

SEE
DETAIL "A"

NOTE:
FOR COMPONENT INFORMATION,
SEE PRODUCT STRUCTURE FOR
428-ANALOG BOARD PROG AND MAN.

NOTE:
FOR OFF BOARD WIRING, USE
BUS WIRE AND COMPONENT LEADS,
AND #18 AWG WIRE.

DO NOT SCALE THIS DRAWING	UNLESS OTHERWISE SPECIFIED	DATE 10/3/80	SCALE NTS	TITLE	COMPONENT LAYOUT
REITELBY METALWORKS INC.	1000 1/2 ST. W. WILSONVILLE, OHIO 45399	MS	1/8"	ANALOG BOARD	
					D 428-100

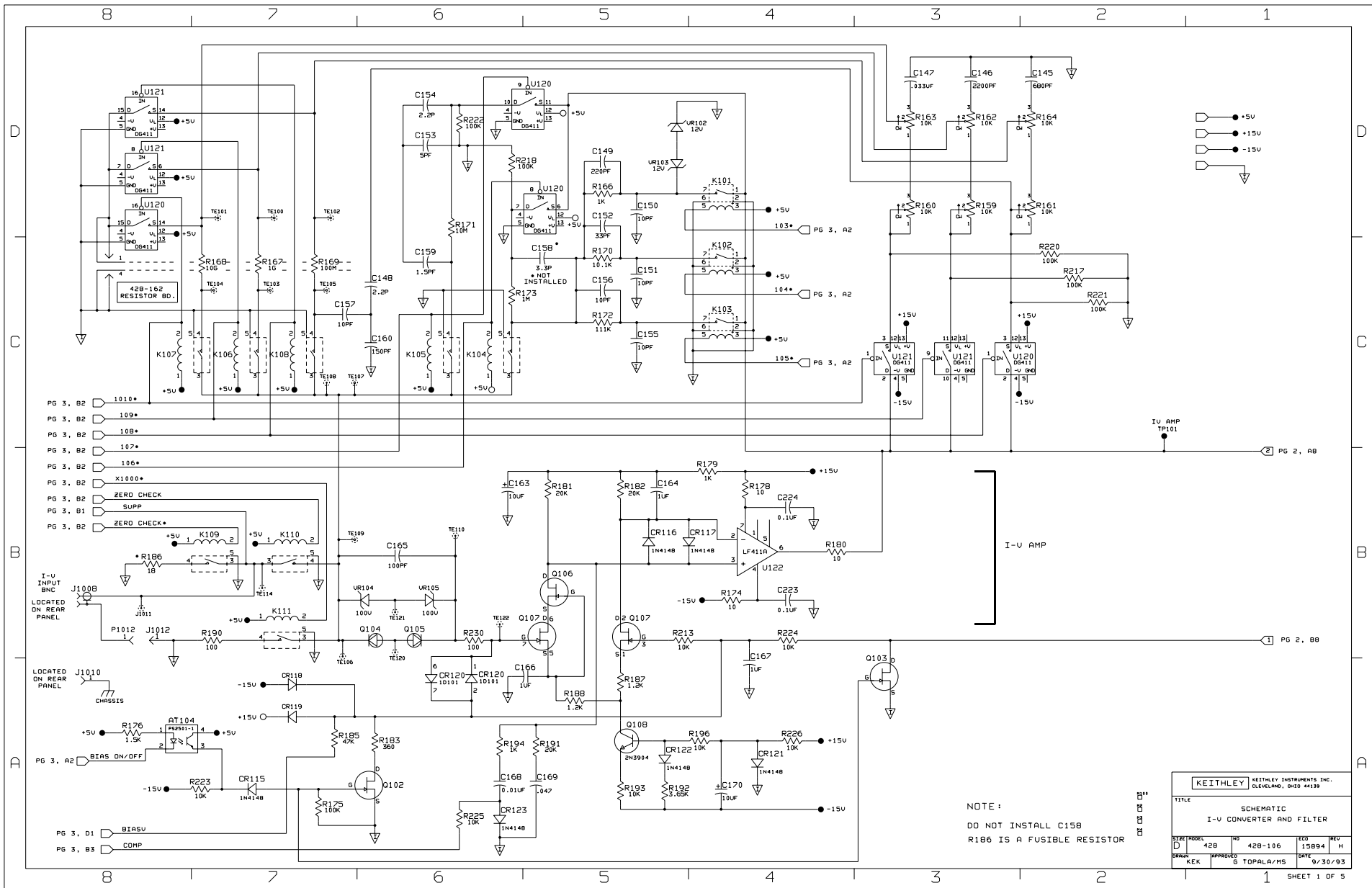

KEITHLEY		KEITHLEY INSTRUMENTS INC. CLEVELAND, OHIO 44139	
TITLE			
I-V CONVERTER AND FILTER		SCHEMATIC	
SIZE	MODEL	REV	ECO
D	428	15894	H
DRN	APPROV	DATE	
KEK	G TOPALA/MS	9/30/93	

NOTE:
DO NOT INSTALL C158
R186 IS A FUSIBLE RESISTOR

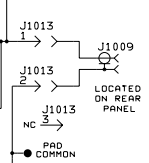
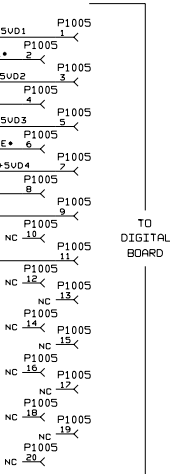
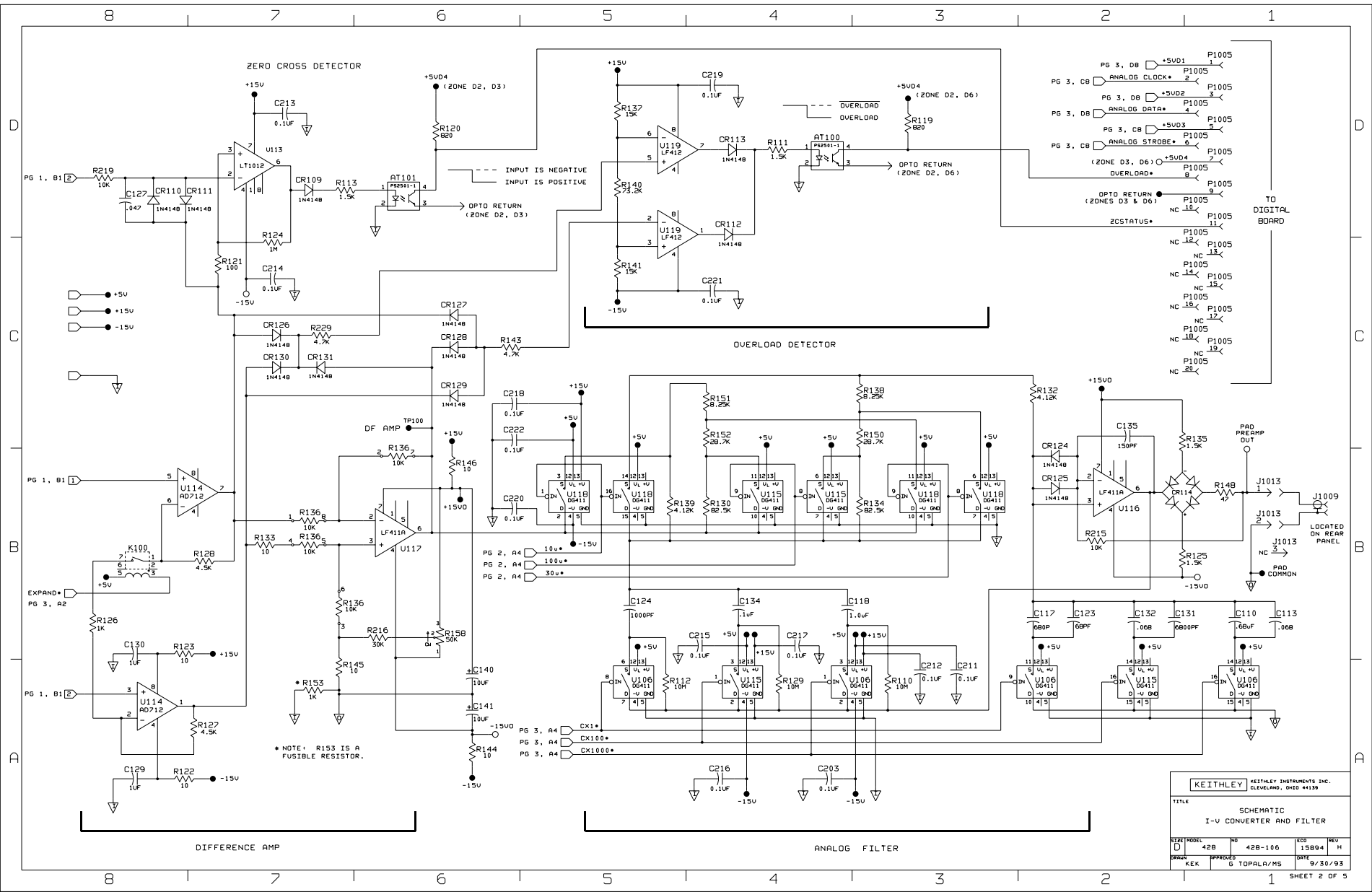

KEITHLEY		KEITHLEY INSTRUMENTS INC.	
		CLEVELAND, OHIO 44139	
TITLE			
SCHEMATIC			
I-V CONVERTER AND FILTER			
REV	MODEL	NO	ECO
D	428	428-106	15894
DRWN	APPROVED	DATE	REV
KEK	G TOPAL/MS	9/30/93	H

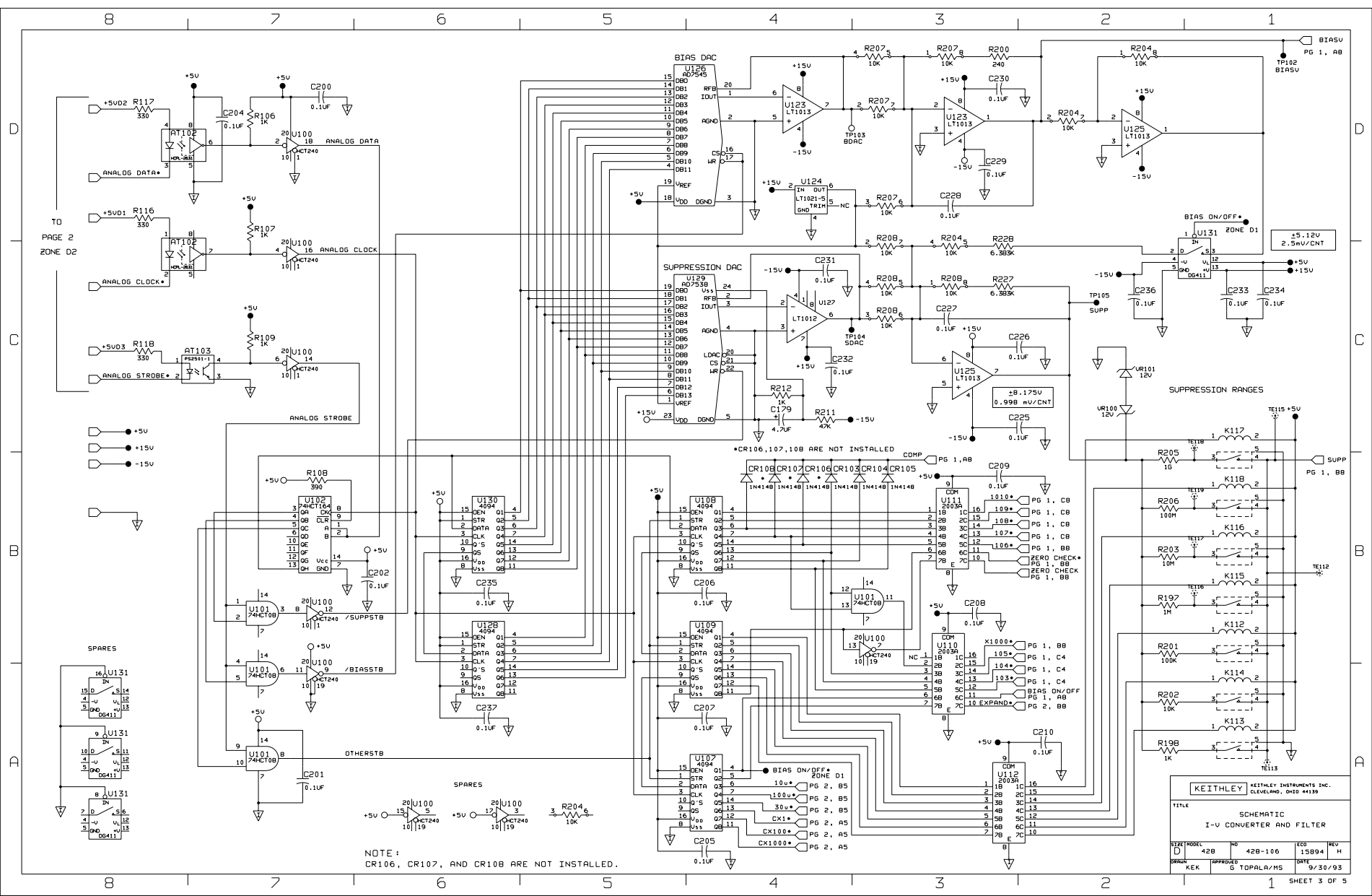

KEITHLEY KEITHLEY INSTRUMENTS INC. CLEVELAND, OHIO 44139			
TITLE		SCHEMATIC	
I-V CONVERTER AND FILTER			
DRAWN	MODEL	ECO	REV
428	428-106	15894	H
DATE	APPROVED	DATE	
9/30/93	G TOPALA/MS	9/30/93	

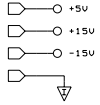

FOR 110/220VAC

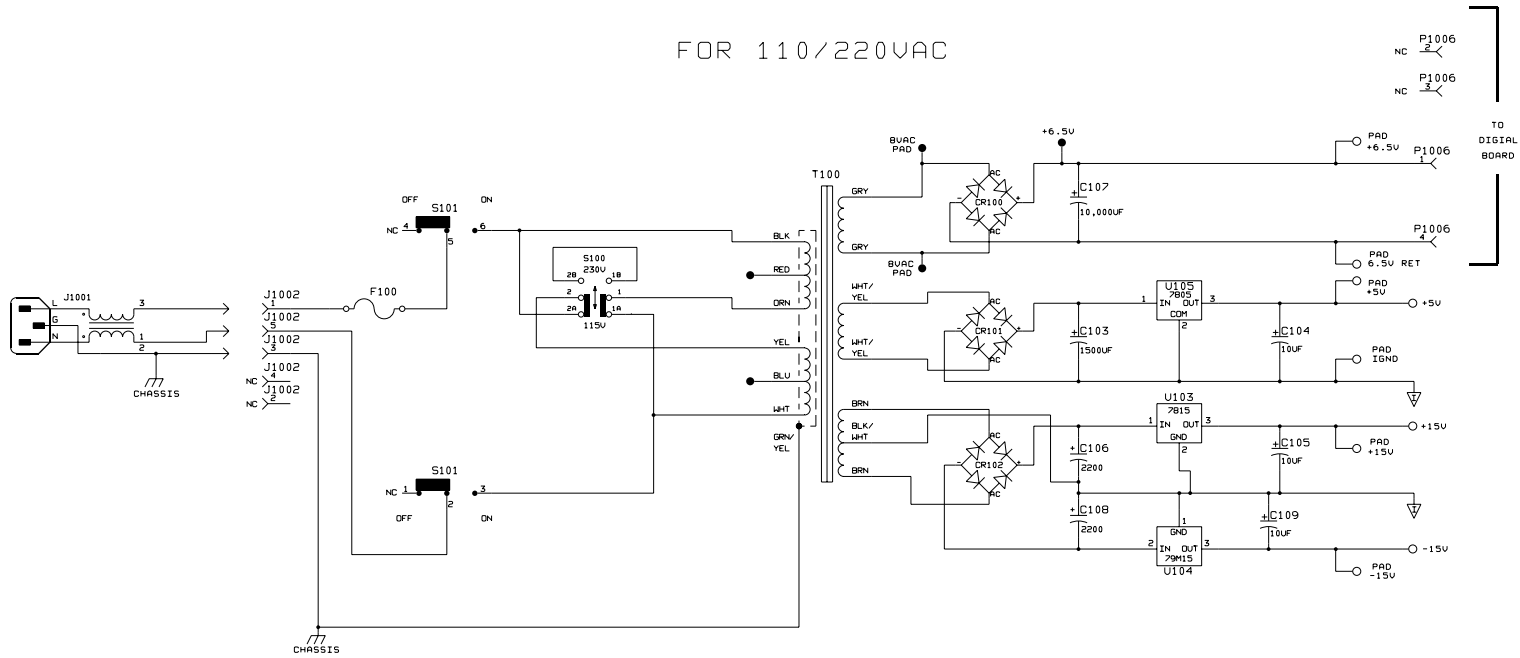

KEITHLEY		KEITHLEY INSTRUMENTS INC. CLEVELAND, OHIO 44139	
TITLE			
SCHEMATIC			
ANALOG BOARD POWER SUPPLY			
SIZE	MODEL	NO	ECO
D	42B	42B-106	15B94
DRWN	KEK	APPROVD	DATE
	G	TOPALA/MS	9/30/93

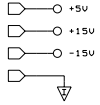

FOR 100/200VAC

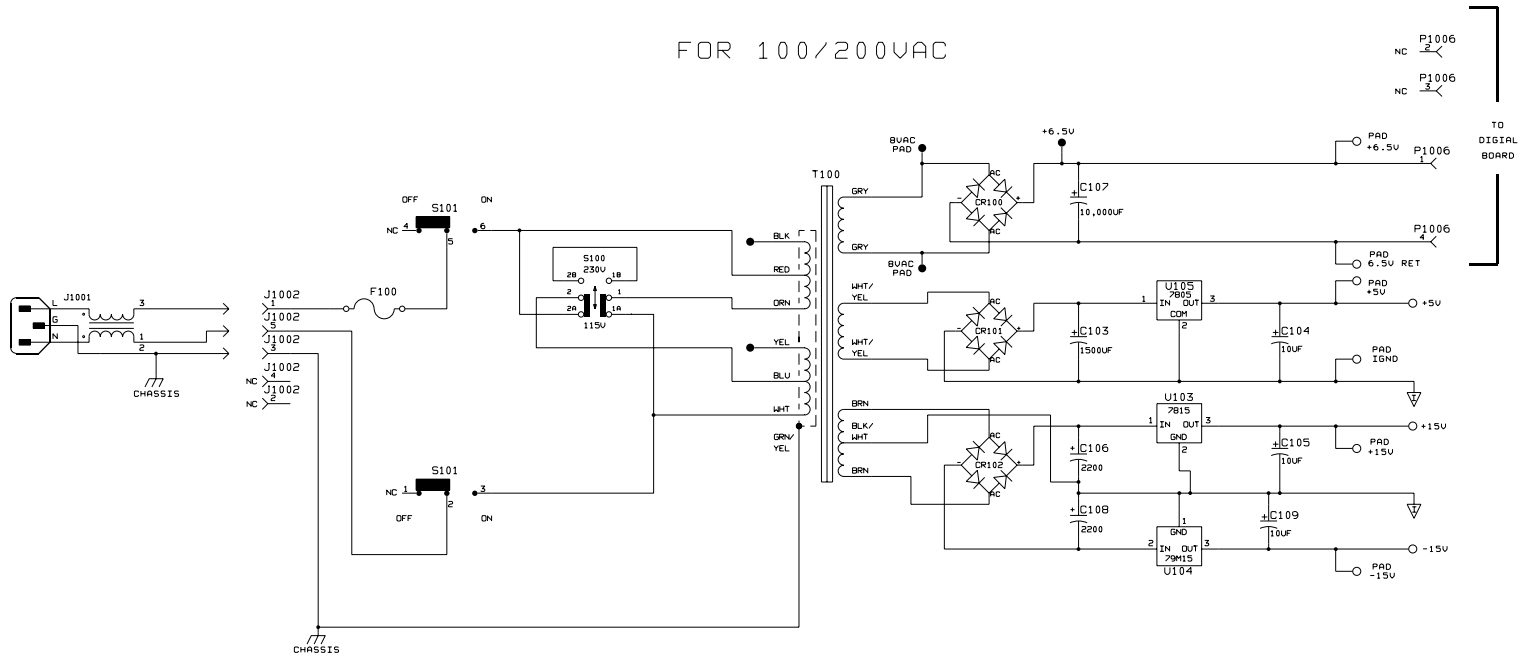

KEITHLEY		KEITHLEY INSTRUMENTS INC. CLEVELAND, OHIO 44139	
TITLE			
SCHEMATIC			
ANALOG BOARD POWER SUPPLY			
SIZE	MODEL	NO	ECO
D	42B	42B-106	15B94
DRWN	KEK	APPROVD	DATE
	G	TOPALA/MS	9/30/93
			SHT 5 OF 5

Model 428 Mechanical, Parts List

Circuit Desig.	Description	Keithley Part No.
	LUG	LU-88
	COVER	428-306
	GASKET	GA-28
	LID, ANALOG SHIELD	428-325
	HANDLE	428-329
	HANDLE MOUNTING EAR, RIGHT	428-328
	HANDLE MOUNTING EAR, LEFT	428-338
	OVERLAY, FRONT PANEL	428-311
	DISPLAY LENS	428-322
	FOOT, EXTRUDED	FE-22
	BEZEL, REAR	428-303
	PUSHBUTTON, POWER	428-318-1
	GASKET	GA-21
	SHIELD, ANALOG BOTTOM	428-317
	SHIELD, ANALOG TOP	428-316
	PUSHROD	428-315
	FRONT PANEL	428-302
	CHASSIS	428-309
	FOOT,RUBBER	FE-6
	KNOB	428-310
	BEZEL, REAR	428-303
	SHIELD, DIGITAL	428-307
	BRACKET, IEEE (428-MAN)	428-321
J1001	LINE FILTER	LF-2
J1008,J1009	CONNECTOR,BNC	CS-249
J1010	BINDING POST	BP-11-5
P1002	HOUSING, CONNECTOR	CS-287-5
P1011	LUG	LU-90
P1012	CONNECTOR	CS-236
P1013	CONNECTOR, HOUSING	CS-638-3

LTR.	ECO NO.	REVISION	ENG.	DATE
B	891031	RELEASED		10-31-89
C	13818	REVISED	MS	12-10-89
D	14673	CHG'D ARTWORK FROM REV C TO D.	AJS	9-5-91

MODEL 'S 487, 486 & 428-PROG. (487-140-01) AS SHOWN

REFER TO 487 (DIGITAL BD.), 486 (DIGITAL BD.) & 428-PROG. (DIGITAL BD.) PRODUCT STRUCTURE FOR COMPLETE COMPONENT INFORMATION.

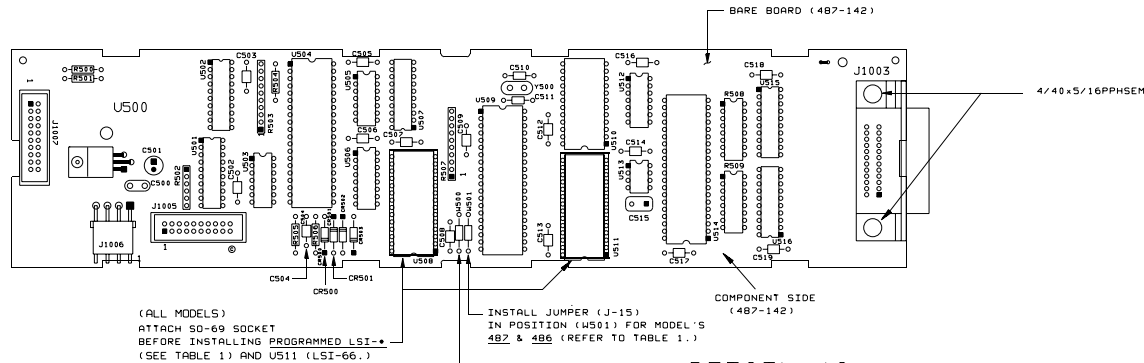
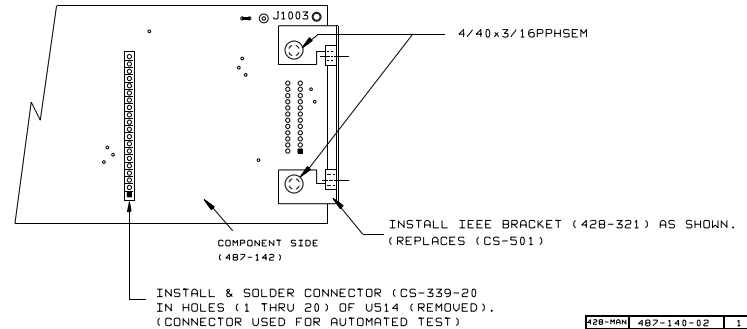

TABLE 1.
JUMPER AND FIRMWARE SELECTION TABLE

JUMPER POSITION		PROGRAMMED LSI-*	
MODEL	ASSEMBLY	U500	U501
428-MAN.	487-140-02	IN	OUT
428-PROG.	487-140-01	IN	OUT
486	487-140-01	OUT	IN
487	487-140-01	OUT	IN

DETAIL 'A
428-MAN (487-140-02)



MODEL 428-MAN. COMPONENT LAYOUT (487-140-02)

1. TO GENERATE MODEL 428-MAN, DIGITAL BD., DELETE THE FOLLOWING COMPONENTS!

CS17 THRU CS19
J1003 (CS-501) IEEE CONNECTOR & REPLACE WITH 428-321 (IEEE BRACKET) SEE DETAIL 'A'
R508 & R509
U516, U515 & U514

2. INSTALL & SOLDER CS-339-20 INTO HOLES (1 - 20) OF U514 SEE DETAIL 'A'
INSTALL JUMPER (J-15) IN POSITION U500 (SEE TABLE 1.)
INSTALL U508 (PROGRAMMED P/N 428-B00) INTO SOCKET (50-69) (SEE TABLE 1.)

3. REFER TO 428-MAN (DIGITAL BD.) PRODUCT STRUCTURE FOR COMPLETE COMPONENT INFORMATION.

DO NOT SCALE THIS DRAWING		DIMENSIONAL TOLERANCES UNLESS OTHERWISE SPECIFIED		DATE 9-06-89	SCALE 1:1	TITLE	COMPONENT LAYOUT, DIGITAL BOARD
KEITHLEY KEITHLEY INSTRUMENTS INC CLEVELAND, OHIO 44139		XX=±.015	ANG.=±1°	DRN. BSK	ENGR. PHM	C	NO. 487-140-*
		XXX=±.025	FRAC.=±1/64	MATERIAL NONE	FINISH NONE		
		SURFACE MAX. 0.3		FINISH NONE			

428-MAN	487-140-02	1
428-PROG	487-140-01	1
486	487-140-01	1
487	487-140-01	1
MODEL NEXT ASSEMBLY QTY. USED ON		

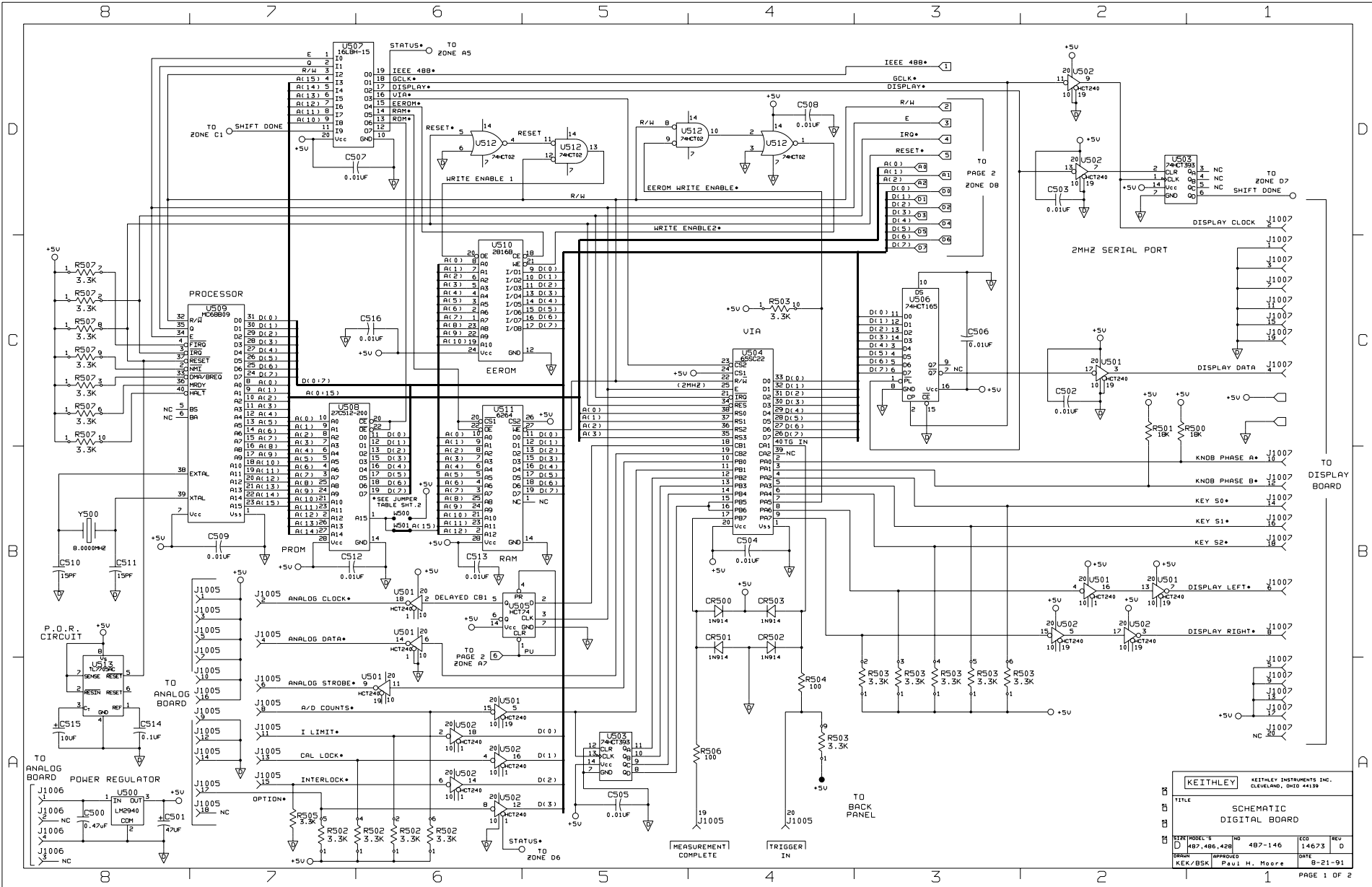

KEITHLEY		KEITHLEY INSTRUMENTS INC. CLEVELAND, OHIO 44139			
TITLE SCHEMATIC DIGITAL BOARD					
SIZE	MODEL	IND	ECO	REV	
D	487-486, 428	487-146	14673	D	
DRWR	APPROVED	DATE	BY		
KEK/BSK	Paul H. Moore	8-21-91			

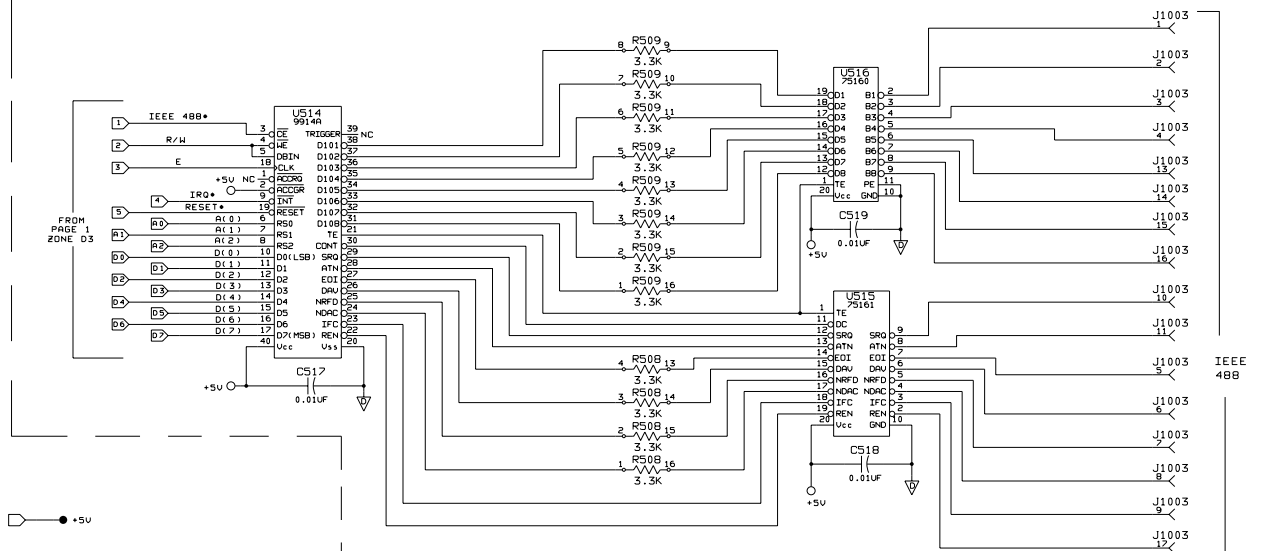

IEEE OPTION
CIRCUITRY SHOWN NOT PRESENT ON MODEL 428-MAN (487-140-02)

REFER TO COMPONENT LAYOUT (487-140-01) FOR CIRCUITRY SHOWN

SPARES

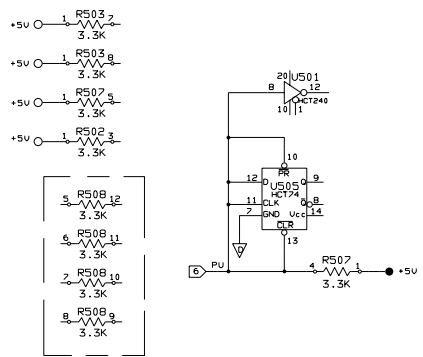

PARTS INDICATED ARE PART OF IEEE OPTION AND ARE NOT PRESENT ON MODEL 428-MAN.

JUMPER AND FIRMWARE SELECTION TABLE

FROM PG. 1 ZONE B6

JUMPER POSITION		PROGRAMMED LSI	
MODEL	W500	W501	US08
428-MAN	IN	OUT	428-B00
428-PRG.	IN	OUT	428-B00
486	OUT	IN	487-B00
487	OUT	IN	487-B00

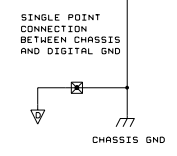

KEITHLEY		KEITHLEY INSTRUMENTS INC. CLEVELAND, OHIO 44139			
TITLE SCHEMATIC DIGITAL BOARD					
SIZE	MODEL S	IND	ECO	REV	
D	487,486,428	487-146	14673	0	
DRWR	APPROVED	DATE	REV		
KEK/BSK	Rev 1	8-21-91	B-21-91		

Model 428 Digital Board, Parts List

Circuit Desig.	Description	Keithley Part No.
C500	CAP, .047UF, 20%, 50V CERAMIC	C-237-.47
C501	CAP, 47UF, -20+100%, 25V, ALUM ELEC	C-314-47
C502..C509, C512, C513, C516..C519*	CAP, .01UF, 20%, 50V, CERAMIC	C-365-.01
C510	CAP, 15PF, 10%, 200V, CERAMIC	C-406-15P
C511	CAP, 15PF, 10%, 200V, CERAMIC	C-406-15P
C514	CAP, .1UF, 20%, 50V, CERAMIC	C-365-.1
C515	CAP, 10UF, 10%, 20V, TANTALUM ELECTROLYTE	C-204-10
CR500..CR503	DIODE, SILICON, IN4148 (DO-35)	RF-28
J1003*	CONN, RIGHT ANGLE, 24 PIN	CS-501
J1004	CONN, STRAIGHT POST HEADER, 3-PIN	CS-533-3
J1005, J1007	CONN, HEADER STRAIGHT SOLDER PIN	CS-368-20
J1006	CONNECTOR, HEADER	CS-715-4
R500, R501	RES, 18K, 5%, 1/4W, COMPOSITION OR FILM	R-76-18K
R502	RES NET, 3.3K, 2%, .6W	TF-101
R503, R507	RES NET, 3.3K, 5%, 1.25W	TF-140
R504, R506	RES, 100, 5%, 1/4W, COMPOSITION OR FILM	R-76-100
R505	RES, 3.3K, 5%, 1/4W, COMPOSITION OR FILM	R-76-3.3K
R508, R509	RES NET, 3.3K, 2%, .25W	TF-77
U500	IC, +5V VOLTAGE REGULATOR, LM2940CT	IC-576
U501, U502	IC, OCTAL TRI STATE BUFFER, 74HCT240	IC-683
U503	IC, DUAL 4 BIT COUNTER, 74HCT393	IC-462
U504	IC, VERSATILE INTERFACE ADAPTER, G655C22	LSI-86
U505	IC, DUAL D FLIP FLOP W/SET & RESE, 74HCT74	IC-515
U506	IC, 8-BIT PARALLEL TO SERIAL, 74HCT165	IC-548
U507	IC, AND-OR-INVERT ARRAY, PAL16L8H-15	IC-687A
U508	EPROM, PROGRAMMED	428-800A
U509	IC, 8 BIT MICROPROCESSING UNIT, MC68B09	LSI-65
U510	IC, PROGRAMMABLE E2ROM 2816B	LSI-83
U511	IC, (8KX8) HI SPEED STATIC CMOS RAM, 6264	LSI-66
U512	IC, QUAD 2-INPUT NOR GATE, 74HCT02	IC-510
U513	IC, SUPPLY VOLTAGE SUPERVISOR, TL7705AC	IC-602
U514*	IC, GPIB ADAPTER, 9914A	LSI-49
U515*	IC, OCTAL INTERFACE BUS TRANSCEIVER, 75161	IC-299
U516*	IC, OCTAL INTERFACE BUS, 75160	IC-298
W500	JUMPER	J-15
Y500	CRYSTAL, 8.0000MHZ	CR-24-1

*428-PROG ONLY

-011-28 ON

LT#	ECNO NO.	REVISION	ENG.	DATE
B	891026	RELEASED	MS	11/28/66
B1	11320	DELETED C404 & RODED U401	SE	03/22/68
C	14675	CHG'D PARTWORK FROM REV B TO C.	RJS	01/27/71
D	18479	228-888V1, 11, 25, 27, 28, 29, 30, 31, 32, 33, 34, 35, 36, 37, 38, 39, 40, 41, 42, 43, 44, 45, 46, 47, 48, 49, 50, 51, 52, 53, 54, 55, 56, 57, 58, 59, 60, 61, 62, 63, 64, 65, 66, 67, 68, 69, 70, 71, 72, 73, 74, 75, 76, 77, 78, 79, 80, 81, 82, 83, 84, 85, 86, 87, 88, 89, 90, 91, 92, 93, 94, 95, 96, 97, 98, 99, 100	SE	4/16/79

MODEL 487 (487-110-01) AS SHOWN

INSTALL 428-320(CARRIER) UNDER DS400 THRU DS409 (ALL MODELS)

INSTALL 50-127 (SPACER) UNDER DS410 (USED ON MODELS 482 & 486 ONLY)

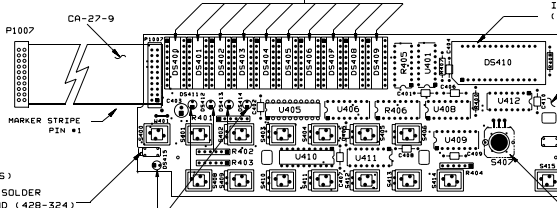

BARE BOARD (487-112) USED FOR MODELS 487, 486, 428-MAN & 428-PROG. FOR MORE COMPONENT INFORMATION REFER TO THE PRODUCT STRUCTURE 487 (DISPLAY BD), 486 (DISPLAY BD) OR 428-MAN (DISPLAY BD) AND, 428-PROG(DISPLAY BD) RESPECTIVELY FOR APPROPRIATE MODEL INFORMATION.

(ALL MODELS)

INSTALL & SOLDER CLIP,GROUND (428-324) SEE DETAIL 'A'

BUSHING (428-314)

(ALL MODELS)

INSTALL & SOLDER CLIP,GROUND (428-324)

SEE DETAIL 'A'

(ALL MODELS)

INSTALL MK-22-4 UNDER DS411 THRU DS415

DETAIL 'A'

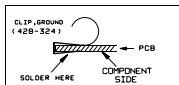

MODEL 486 (487-110-03)

MODEL 'S' 428-MAN & 428-PROG. (487-110-02)

1. TO GENERATE THE MODEL 486 DISPLAY BOARD (487-110-03) DELETE THE FOLLOWING COMPONENTS (487-110-01).

S406,S413

2. REFER TO PRODUCT STRUCTURE 486(DISPLAY BD) FOR COMPLETE COMPONENT INFO.

1. TO GENERATE THE MODEL 428 DISPLAY BOARDS (487-110-02) DELETE THE FOLLOWING COMPONENTS (487-110-01).

C400,C406,C410
DS410 & 50-127
U409,U412,U404,
R407,R408

2. REPLACE S411 (5W-481), WITH A (5W-482).

3. REFER TO PRODUCT STRUCTURE 428-MAN (DISPLAY BD) AND 428-PROG (DISPLAY BD) FOR COMPLETE COMPONENT INFORMATION.

428-PROG	1
428-MAN	1
428	1
427	1
MODEL NEXT ASSEMBLY	017

DO NOT SCALE THIS DRAWING		DIMENSIONS TO TOLERANCES UNLESS OTHERWISE SPECIFIED		DATE 8-16-80	SCALE 1:1	TITLE	COMPONENT LAYOUT, DISPLAY BOARD
XXX+.013	ANG. ±1°	DRN. BSK	DRW.				
XXX+.005	FRC. ±1/64	MATERIAL	NONE				
	SURFACE MAX. 63	FINISH	NONE				
RETIHEY MILITARY INSTRUMENTS INC. DEVELOPMENT, DIVD 44139							NO. 487-110-# C

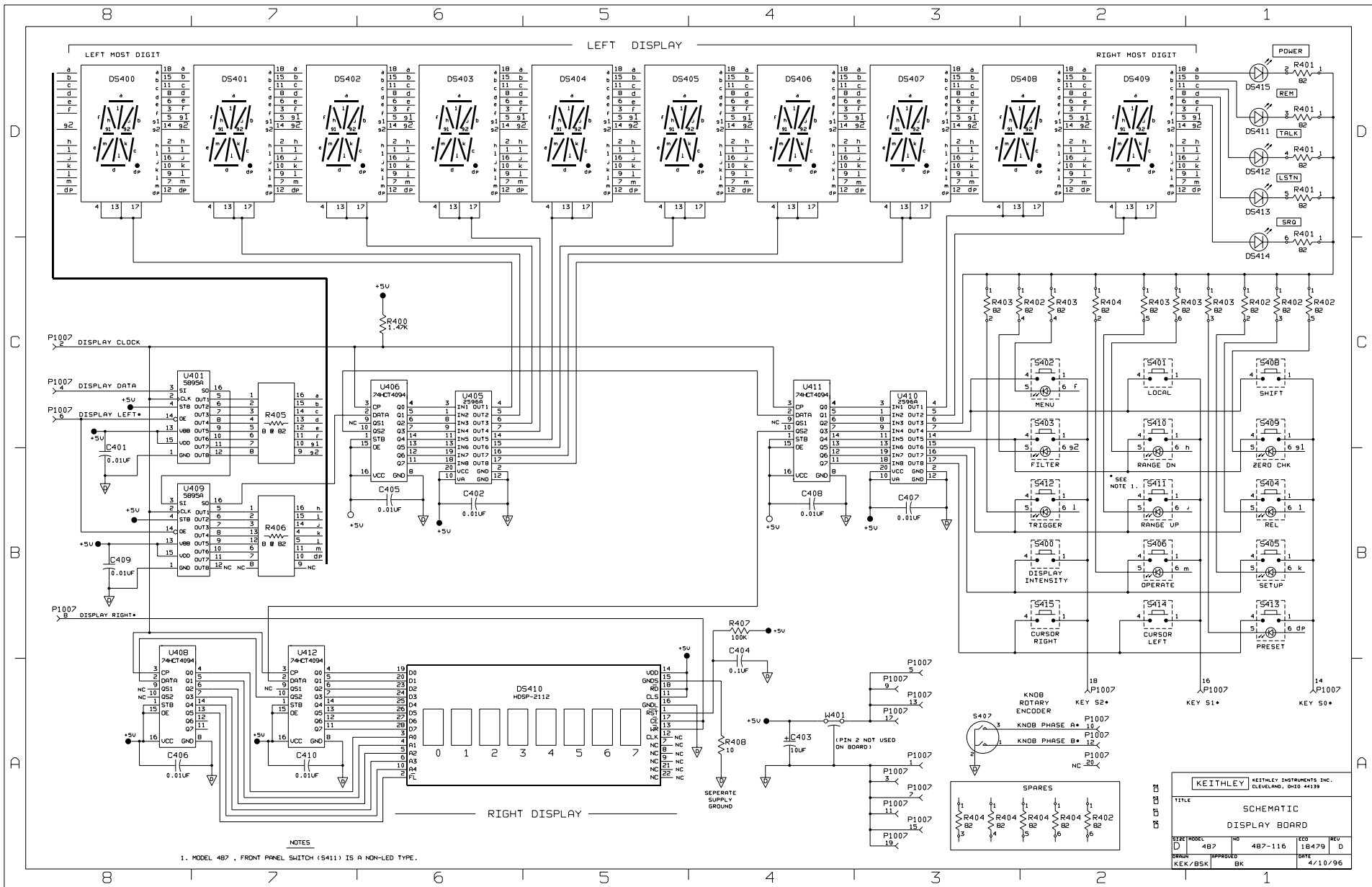

NOTES
 1. MODEL 487, FRONT PANEL SWITCH (S411) IS A NON-LED TYPE.

KEITHLEY		KEITHLEY INSTRUMENTS INC. CLEVELAND, OHIO 44139	
SCHEMATIC DISPLAY BOARD			
DATE	APPROVED	REV	REV
D 487	BK	487-116	18479 0
DATE			4/10/96

Model 428 Display Board, Parts List

Circuit Desig.	Description	Keithley Part No.
C401,C402,C405,C407..C409 C403	CAP,.01UF,20%,50V,CERAMIC CAP, 10UF,-20+100%,25V,ALUM ELEC	C-365-.01 C-314-10
DS400..DS409 DS411..DS415	DIGITAL DISPLAY PILOT LIGHT, RED,LED	DD-46 PL-83
P1007	CABLE ASSEMBLY, 20 CONDUCTOR	CA-27-9B
R400 R401..R404 R405,R406	RES,1.47K,1%,1/8W,METAL FILM RES NET, 82, 2%,.2W RES NET,82,2%,.25W	R-88-1.47K TF-223-82 TF-141
S400,S401,S408,S414,S415 S402..S406,S409..S413 S407	SWITCH, MOMENTARY SWITCH, MOMENTARY W/LED, HIGH EFF.,RED SWITCH, ENCODER, DIG 2-BIT GRAY CODE	SW-481 SW-482 SW-480
U401,U409 U405,U410 U406,U411	IC,8-BIT SERIAL-INPUT,UNC5895A IC,8-CHANNEL SAT SINK DRIVER,UDN-2596A IC,8-STAGE SHIFT/STORE REG,74HCT4094 USED WITH DS400..DS409 SOCKET, CARRIER USED WITH DS411..415 MOUNTING KIT	IC-537 IC-578 IC-691 428-320A MK-22-4

APPENDIX A

Device-dependent Command Summary

Table A-1. Device-dependent Command Summary

Mode	Command	Description	Para.
Display intensity	A0	Normal	4.2.1
	A1	Dim	
	A2	Off	
Bias on/off	B0	Turn voltage bias off	4.2.2
	B1	Turn voltage bias on	
Zero check/ zero correct	C0	Turn zero check off	4.2.3
	C1	Turn zero check on	
	C2	Perform auto zero correct	
Display	DaaaaX	Display string aaa (10 max.)	4.2.4
	Dx	Return to normal display	
Hit key	H1	DISPLAY INTENSITY	4.2.5
	H2	LOCAL	
	H3	SHIFT	
	H4	MENU	
	H5	ZERO CHECK	
	H6	SETUP GAIN	
	H7	SETUP FILTER RISE TIME	
	H8	SETUP CURRENT SUPPRESS	
	H9	SETUP VOLTAGE BIAS	
	H10	ENABLE GAIN X10	
	H11	ENABLE FILTER	
	H12	ENABLE CURRENT SUPPRESS	
	H13	ENABLE VOLTAGE BIAS	
	H14	◀	
	H15	▶	
	H16	Knob rotation counter clockwise	
	H17	Knob rotation clockwise	
Self-test	J0	Test ROM and RAM only	4.2.6
	J1	Test ROM, RAM, and display	
EOI, holdoff	K0	Enable EOI, enable holdoff on X	4.2.7
	K1	Disable EOI, enable holdoff on X	
	K2	Enable EOI, disable holdoff on X	
	K3	Disable EOI, disable holdoff on X	
Save/recall	L0	Restore factory default and save	4.2.8
	L1	Save configuration as power on	
	L2	Restore power-on conditions	

Device-dependent Command Summary Cont.

Mode	Command	Description	Para.
SRQ mask	M1 M2 M4 M8 M16 M32	Overload Front panel key press Not used Not used Ready for command U1 error	4.2.9
Suppression on/off	N0 N1 N2	Turn suppression off Turn suppression on Automatic suppress	4.2.10
Filter	P0 P1	Turn filter off Turn filter on	4.2.11
Gain	R0 R1 R2 R3 R4 R5 R6 R7 R8 R9 R10	10^3 V/A gain 10^3 V/A gain 10^3 V/A gain 10^3 V/A gain 10^4 V/A gain 10^5 V/A gain 10^6 V/A gain 10^7 V/A gain 10^8 V/A gain 10^9 V/A gain 10^{10} V/A gain	4.2.12
Suppression value, range	S, 0 Sn, 1 Sn, 2 Sn, 3 Sn, 4 Sn, 5 Sn, 6 Sn, 7 Sn, 8 Sn, 9 Sn, 10	Enable auto-ranging (bus only) n = value, ± 5 nA range n = value, ± 50 nA range n = value, ± 500 nA range n = value, ± 5 μ A range n = value, ± 50 μ A range n = value, ± 500 μ A range n = value, ± 5 mA range IDDCO IDDCO Disable auto-ranging (bus only)	4.2.13
Rise time	T0 T1 T2 T3 T4 T5 T6 T7 T8 T9	10 μ sec 30 μ sec 100 μ sec 300 μ sec 1msec 3msec 10msec 30msec 100msec 300msec	4.2.14

Device-dependent Command Summary Cont.

Mode	Command	Description	Para.
Alternate output	U0	Send machine status word	4.2.15
	U1	Send error status word	
	U2	Send bias value	
	U3	Send total gain	
	U4	Send model number, revision	
Bias value	Vn	$-5 \leq n \leq +5$ V, 2.5mV resolution	4.2.16
X10 gain on/off	W0	Turn X10 gain off	4.2.17
	W1	Turn X10 gain on	
Execute	X	Execute DDCs previously sent	4.2.18
Terminator	Y0	<CR><LF>	4.2.19
	Y1	<LF><CR>	
	Y2	<CR>	
	Y3	<LF>	
Auto-filter	Z0	Turn auto-filter off	4.2.20
	Z1	Turn auto-filter on	

APPENDIX B

Interface Function Codes

The interface function codes, which are part of the IEEE-488 standards, define an instrument's ability to support various interface functions and should not be confused with programming commands found elsewhere in this manual. The interface function codes for the Model 428 are listed in Table B-1. The codes define Model 428 capabilities as follows:

SH (Source Handshake Function) — SH1 defines the ability of the instrument to initiate the transfer of message/data over the data bus.

AH (Acceptor Handshake Function) — AH1 defines the ability of the instrument to guarantee proper reception of message/data transmitted over the data bus.

T (Talker Function) — The ability of the instrument to send data over the bus to other devices is provided by the T function. Instrument talker capabilities (T6) exist only after the instrument has been addressed to talk.

L (Listener Function) — The ability for the instrument to receive device-dependent data over the bus from other devices is provided by the L function. Listener capabilities (L4) of the instrument exist only after it has been addressed to listen.

SR (Service Request Function) — SR1 defines the ability of the instrument to request service from the controller.

RL (Remote-Local Function) — RL1 defines the ability of the instrument to be placed in the remote or local modes.

PP (Parallel Poll Function) — The instrument does not

have parallel polling capabilities (PP0).

DC (Device Clear Function) — DC1 defines the ability of the instrument to be cleared (initialized).

DT (Device Trigger Function) — The Model 428 has no device trigger capability (DT0).

C (Controller Function) — The instrument does not have controller capabilities (C0).

TE (Extended Talker Function) — The instrument does not have extended talker capabilities (TE0).

LE (Extended Listener Function) — The instrument does not have extended listener capabilities (LE0).

E (Bus Driver Type) — The instrument has open-collector bus drivers (E1).

Table B-1. Model 428 Interface Function Codes

Code	Interface Function
SH1	Source Handshake capability
AH1	Acceptor Handshake capability.
T6	Talker (basic talker, serial poll, unaddressed to talk on LAG)
L4	Listener (basic listener, unaddressed to listen on TAG)
SR1	Service Request capability
RL1	Remote/Local capability
PP0	No Parallel Poll capability
DC1	Device Clear capability
DT0	No Device Trigger capability
C0	No Controller capability
E1	Open Collector Bus Drivers
TE0	No Extended Talker capabilities
LE0	No Extended Listener capabilities

APPENDIX C

ASCII Character Codes and IEEE-488

Multiline Interface Command Messages

Decimal	Hexadecimal	ASCII	IEEE-488 Messages*
0	00	NUL	
1	01	SOH	GTL
2	02	STX	
3	03	ETX	
4	04	EOT	SDC
5	05	ENQ	PPC
6	06	ACK	
7	07	BEL	
8	08	BS	GET
9	09	HT	TCT
10	0A	LF	
11	0B	VT	
12	0C	FF	
13	0D	CR	
14	0E	SO	
15	0F	SI	
16	10	DLE	
17	11	DC1	LLO
18	12	DC2	
19	13	DC3	
20	14	DC4	DCL
21	15	NAK	PPU
22	16	SYN	
23	17	ETB	
24	18	CAN	SPE
25	19	EM	SPD
26	1A	SUB	
27	1B	ESC	
28	1C	FS	
29	1D	GS	
30	1E	RS	
31	1F	US	

* Message sent or received with ATN true.

APPENDIX C
ASCII Character Codes and IEEE-488
Multiline Interface Command Messages

Decimal	Hexadecimal	ASCII	IEEE-488 Messages*
32	20	SP	MLA 0
33	21	!	MLA 1
34	22	"	MLA 2
35	23	#	MLA 3
36	24	\$	MLA 4
37	25	%	MLA 5
38	26	&	MLA 6
39	27	'	MLA 7
40	28	(MLA 8
41	29)	MLA 9
42	2A	*	MLA 10
43	2B	+	MLA 11
44	2C	,	MLA 12
45	2D	-	MLA 13
46	2E	.	MLA 14
47	2F	/	MLA 15
48	30	0	MLA 16
49	31	1	MLA 17
50	32	2	MLA 18
51	33	3	MLA 19
52	34	4	MLA 20
53	35	5	MLA 21
54	36	6	MLA 22
55	37	7	MLA 23
56	38	8	MLA 24
57	39	9	MLA 25
58	3A	:	MLA 26
59	3B	;	MLA 27
60	3C	<	MLA 28
61	3D	=	MLA 29
62	3E	>	MLA 30
63	3F	?	UNL

* Message sent or received with ATN true. Numbers shown represent primary address resulting in MLA (My Listen Address).

Decimal	Hexadecimal	ASCII	IEEE-488 Messages*
64	40	@	MTA 0
65	41	A	MTA 1
66	42	B	MTA 2
67	43	C	MTA 3
68	44	D	MTA 4
69	45	E	MTA 5
70	46	F	MTA 6
71	47	G	MTA 7
72	48	H	MTA 8
73	49	I	MTA 9
74	4A	J	MTA 10
75	4B	K	MTA 11
76	4C	L	MTA 12
77	4D	M	MTA 13
78	4E	N	MTA 14
79	4F	O	MTA 15
80	50	P	MTA 16
81	51	Q	MTA 17
82	52	R	MTA 18
83	53	S	MTA 19
84	54	T	MTA 20
85	55	U	MTA 21
86	56	V	MTA 22
87	57	W	MTA 23
88	58	X	MTA 24
89	59	Y	MTA 25
90	5A	Z	MTA 26
91	5B	[MTA 27
92	5C	\	MTA 28
93	5D]	MTA 29
94	5E	^	MTA 30
95	5F	_	UNL

* Message sent or received with ATN true. Numbers shown are primary address resulting in MTA (My Talk Address).

Decimal	Hexadecimal	ASCII	IEEE-488 Messages*
96	60	∘	MSA 0,PPE
97	61	a	MSA 1,PPE
98	62	b	MSA 2,PPE
99	63	c	MSA 3,PPE
100	64	d	MSA 4,PPE
101	65	e	MSA 5,PPE
102	66	f	MSA 6,PPE
103	67	g	MSA 7,PPE
104	68	h	MSA 8,PPE
105	69	i	MSA 9,PPE
106	6A	j	MSA 10,PPE
107	6B	k	MSA 11,PPE
108	6C	l	MSA 12,PPE
109	6D	m	MSA 13,PPE
110	6E	n	MSA 14,PPE
111	6F	o	MSA 15,PPE
112	70	p	MSA 16,PPD
113	71	q	MSA 17,PPD
114	72	r	MSA 18,PPD
115	73	s	MSA 19,PPD
116	74	t	MSA 20,PPD
117	75	u	MSA 21,PPD
118	76	v	MSA 22,PPD
119	77	w	MSA 23,PPD
120	78	x	MSA 24,PPD
121	79	y	MSA 25,PPD
122	7A	z	MSA 26,PPD
123	7B	{	MSA 27,PPD
124	7C		MSA 28,PPD
125	7D	}	MSA 29,PPD
126	7E	~	MSA 30,PPD
127	7F	DEL	

* Message sent or received with ATN true. Numbers represent secondary address values resulting in MSA (My Secondary Address).

APPENDIX D

Controller Programs

The following programs have been supplied as a simple aid to the user and are not intended to suit specific needs. Each program allows you to send a device-dependent command string to the instrument and obtain and display a string from the instrument.

Programs for the following controllers are included:

- A BASIC program for an IBM PC/XT/AT with a Capital Equipment Corporation PC<>488 Interface (Keithley Model PC-488-CEC IEEE-488 Interface Card).
- A program written with the ASYST software package (available from Keithley Instruments) for an IBM PC/XT/AT with a Capital Equipment Corporation PC<>488 Interface.
- A BASIC program for an IBM PC/XT/AT with IOtech Driver488 Software.
- A BASIC program for an IBM PC/XT/AT with a National GPIB PC Interface.
- A BASIC program for a Hewlett-Packard Model 9000 Series 200/300 computer.

IBM PC/XT/AT with Capital Equipment Corporation PC<>488 Interface (Keithley PC-488-CEC)

Introduction

General information about controlling a Model 428 with an IBM PC/XT/AT computer and Capital Equipment Corporation PC<>488 interface is given here. Refer to the CEC PC<>488 Programming and Reference Manual for complete information.

Initializing the System

The first step in any program is to initialize the system using the INITIALIZE routine. This routine sets the primary IEEE-488 bus address of the PC<>488, specifies the type of controller to be used, and sends an interface clear (IFC) to the other devices on the bus.

After booting up the IBM using DOS and entering BASICA, the statements of program 1 can be used at the start of any program to initialize the system:

Line 30 sets the address of the PC<>488 to 21, however, any other valid address could be used as long as it does not conflict with the address of any other device on the bus.

Interface Basic Programming Statements

This paragraph covers the PC<>488 statements that are essential to Model 428 operation. A partial list of programming statements is contained in Table D-1. The IBM

BASIC CALL statement is used to execute the desired action. Before a CALL routine can be used, BASIC needs to know the offset address of the routine. In the table, the first statement of each programming sequence defines the offset address of the CALL routine.

Example Program

The following program sends a command string from an IBM PC/XT/AT computer to the Model 428 and displays the response on the CRT. The computer must be equipped with a CEC interface card and DOS 2.0 (or later revision) operating system.

Directions

1. Using the front panel MENU key, set the primary IEEE-488 address of the Model 428 to 22.
2. With the power off, connect the Model 428 to the IEEE-488 interface card installed in the IBM computer.
3. Type in BASICA on the computer keyboard to get into interpretive BASIC language.
4. Enter the lines of Program 2 using the return key after each line.
5. Run the program and type in the desired command string at the ENTER COMMAND STRING? prompt. For example, to view the instrument model number and firmware revision, type in U4X and press the return key. The Model 428 firmware revision, (e.g. 428A01, will then appear on the computer display. The suppress value will be displayed if you send a command other than U.

PROGRAM	COMMENTS
10 DEF SEG=&HC400	' Memory offset.
20 INITIALIZE=0	' Offset address of routine
30 MY.ADDRESS%=21	' Set PC<>488 address.
40 CONTROLLER%=0	' Set for system control.
50 CALL INITIALIZE (MY.ADDRESS%, CONTROLLER%)	' Execute INITIALIZE routine.

Program 1

PROGRAM	COMMENTS
10 DEF SEG=&HC400	' Memory address
20 INITIALIZE=0	' Define call offsets
30 SEND=9:ENTER=21	
40 MY.ADDRESS%=21	' Set PC<>488 address
50 INST.ADDRESS%=22	' Set 428 address
60 CONTROLLER%=0	' Set for system control
70 CALL INITIALIZE (MY.ADDRESS%, CONTROLLER%)	' Initialize system
80 LINE INPUT "ENTER COMMAND STRING:";CMD\$	' Prompt for string
90 CALL SEND (INST.ADDRESS%,CMD\$, STATUS%)	' Send command string
100 RESPONSE\$=SPACE\$(80)	' Make room for data
110 CALL ENTER (RESPONSE\$,LENGTH%, INST.ADDRESS%,STATUS%)	' Get response from 428
120 PRINT RESPONSE\$	' Display response
130 GOTO 80	' Repeat
140 END	

Program 2

Table D-1. BASIC Statements Necessary to Send Bus Commands

Action	PC<>488 Statements
Transmit command string (CMD\$) to device 22.	SEND=9 ADDRESS%=22 CALL SEND(ADDRESS%,CMD\$,STATUS%)
Obtain string from device 22.	ENTER=21 ADDRESS%=22 RESPONSE\$=SPACE\$(50) CALL ENTER(RESPONSE\$,LENGTH%,ADDRESS%,STATUS%)
Send GTL to device 22.	TRANSMIT=3 CMD\$="LISTEN 22 GTL" CALL TRANSMIT(CMD\$,STATUS%)
Send SDC to device 22.	TRANSMIT=3 CMD\$="LISTEN 22 SDC" CALL TRANSMIT(CMD\$,STATUS%)
Send DCL to all devices.	TRANSMIT=3 CMD\$="LISTEN 22 DCL" CALL TRANSMIT(CMD\$,STATUS%)
Send remote enable.	TRANSMIT=3 CMD\$="REN LISTEN 22" CALL TRANSMIT(CMD\$,STATUS%)
Serial poll device 22.	SPOLL=12 ADDRESS%=22 CALL SPOLL%(ADDRESS%,POLL%,STATUS%)

IBM PC/XT/AT with CEC PC<>488 Interface and ASYST Software Package

Introduction

ASYST contains data acquisition, analysis, and graphing software in three integrated modules. Minimum requirements for ASYST include: 512K RAM (640K recommended), math coprocessor, parallel port, hard drive, and DOS 2.0 (or later version) operating system.

For this example, an optional software module is required for IEEE-488 interfacing. The computer must also be equipped with a CEC interface card (PC<>488 Model 300 or 310, or 4x488).

The ASYST program listed here sends a command string from an IBM PC/XT/AT computer to the Model 428 and displays the response on the computer's CRT.

Directions

This procedure will help an ASYST user through the steps necessary for GPIB configuration, program entry, and program execution. Refer to the ASYST documentation for more detailed instructions.

3. Boot ASYST software from DOS. You will get an OK prompt.
4. Use the <F2> key to enter the Main Configuration Menu. In addition to the usual configuration requirements of ASYST, the GPIB must be configured.

From the Overlay Configuration Menu, select overlays GPIB Master and Type 1 NEC GPIB Driver.

From the GPIB Configuration Menu, select a bus number, board type (National GPIB-PC1 or GPIB-PC2 for ASYST 2.0, Capital - NEC uPD7210 model for ASYST 3.0), memory address (2B8), primary address (0), and interrupt line.

5. Save your changes and return to the OK prompt.
6. Use the command line editor (EDIT 428.DMO) to enter the following program. Save the program and exit the editor.
7. When prompted, load the program with the L key, or type LOAD 428.DMO from the OK prompt.
8. When the program loads properly, type MAIN from the OK prompt to start execution.
9. Type in the desired command string at the "Enter command string:" prompt. For example, to view the instrument model number and firmware revision, type in U4X and press the return key. The Model 428 firmware revision, (e.g. 428A01) will then appear on the computer display. The suppress value will be displayed if you send a command other than U.
10. Type <Control-Break> to exit the program loop of 428.DMO and return to the OK prompt. The program-defined words can be removed from the ASYST dictionary by typing FORGET 428.

1. Using the front panel MENU key, set the primary address of the Model 428 to 22.
2. With the power off, connect the Model 428 to the IEEE-488 interface card installed in the IBM computer.

PROGRAM	COMMENTS
BUS.INIT	\ Initialize bus
SEND.INTERFACE.CLEAR	\ Take control of bus
REMOTE.ENABLE.ON	\ Allow remote operation
SYNCHRONOUS.GPIB	\ Make sure ASYST is in sync. mode
?GPIB.DEVICES	\ List controller parameters
22 GPIB.DEVICE 428	\ Set 428 address and name
EOI.ON	\ Enable end or identify
EOS.ON	\ Enable end of string terminator
10 EOS.CHARACTER	\ Use LF terminator
1000 TIMEOUT	\ Set timeout of 1sec
?GPIB.DEVICE	\ List 428 parameters
100 STRING COMMAND	\ Allocate 100 bytes for user input
100 STRING RESPONSE	\ Allocate 100 bytes for 428 response
: GET.INPUT	\ Definition for user input
CR." ENTER COMMAND STRING:"	\ Prompt user
"INPUT COMMAND ":=	\ Get DDCs
;	
: MAIN	\ Definition for main program
BEGIN	\ Start loop
ME	\ Make controller current device
GET.INPUT	\ Get DDCs from user
428	\ Make 428 current device
COMMAND GPIB.WRITE	\ Send DDCs to 428
RESPONSE GPIB.READ	\ Get response
CR RESPONSE "TYPE	\ Display response
AGAIN	\ Return for more commands
;	

IBM PC/XT/AT or PS/2 with IOtech Driver488 Software

Introduction

Driver488 software is an IEEE-488 driver for IBM PC and compatible computers. When combined with an IEEE-488 interface board, the package can control devices from languages including BASIC, Pascal, Fortran, and C. Driver488 software is compatible with:

- IOtech GP488B or GP488/2 boards
- National Instruments GPIB-PC, PCII, PCIIA, or PCIII boards
- Capital Equipment #01000-00300 board
- IBM GPIB Adapter

The following GW-BASIC program sends a command string to the Model 428 and displays the instrument response on the CRT. The computer must be equipped with an IEEE-488 interface board, the DOS 3.00 (or later) operating system, and a language with DOS I/O capability. Driver488 controller software must be installed and configured as described in the instruction manual.

Directions

1. Using the front panel MENU key, set the primary address of the Model 428 to 22.
2. With power off, connect the Model 428 to the IEEE-488 interface installed in the IBM computer.
3. Type in GWBASIC on the computer and get into the Microsoft interpretive BASIC language.
4. Enter the lines below using the return key after each line.
5. Run the program and type in the desired command string at the COMMAND STRING prompt. For example, to view the instrument model number and firmware revision, type in U4X and press the return key. The Model 428 firmware revision, (e.g. 428A01) will then appear on the computer display. The suppress value will be displayed if you send a command other than U.

PROGRAM	COMMENTS
10 OPEN "\DEV\IEEEOUT" FOR OUTPUT AS #1	' Open file for output
20 IOCTL#1, "BREAK"	' Reset
30 PRINT#1, "RESET"	
40 OPEN "\DEV\IEEEIN" FOR INPUT AS #2	' Open file for input
50 PRINT#1, "FILL ERROR"	' Enable SEQUENCE error detect
60 LINE INPUT "COMMAND STRING: ";A\$	' Prompt for and get DDCs
70 IF LEN(A\$)=0 THEN 130	' Check for null
80 PRINT #1, "OUTPUT 22;" +A\$	' Address 428 to listen, send DDCs
90 PRINT #1, "ENTER 22"	' Address 428 to talk
100 LINE INPUT#2,B\$	' Get response
110 PRINT B\$	' Display response string
120 GOTO 60	' Repeat
130 END	

IBM PC/XT/AT with National GPIB PC Interface

Introduction

The following program sends a command string to the Model 428 from an IBM PC/XT/AT computer and displays the instrument reading string on the CRT. The computer must be equipped with the National GPIB PC Interface and the DOS 2.00 (or later revision) operating system. Interface software must be installed and configured as described in the instruction manual.

Directions

- Using the front panel MENU key, set the primary address of the Model 428 to 22.
- With the power off, connect the Model 428 to the IEEE-488 interface installed in the IBM computer.
- Type in BASICA on the computer keyboard to get into the IBM interpretive BASIC language.
- Place the interface software disk in the default drive, type LOAD"DECL", and press the return key.
- Add the lines below to lines 1-6 which are now in memory. Modify the address in lines 1 and 2, as described in the National instruction manual.
- Run the program and type in the desired command string. For example, to view the instrument model number and firmware revision, type in U4X and press the return key. The Model 428 firmware revision, (e.g. 428A01) will then appear on the computer display. The suppress value will be displayed if you send a command other than U.

PROGRAM	COMMENTS
10 CLS	Clear screen.
20 NA\$="GPIB0":CALL IBFIND(NA\$,BRD0%)	Find board descriptor.
30 NA\$="DEV1":CALL IBFIND(NA\$,M428%)	Find instrument descriptor.
40 V%=22:CALL IBPAD(M428%,V%)	Set primary address to 22.
50 V%=&H102:CALL IBPOKE(BRD0%,V%)	Set timeouts.
60 V%=1:CALL IBSRE(BRD0%,V%)	Set REN true.
70 INPUT "COMMAND STRING";CMD\$	Prompt for command.
80 IF CMD\$="EXIT" THEN 150	See if program is to be halted.
90 IF CMD\$="" THEN 70	Check for null input.
100 CALL IBWRT (M428%,CMD\$)	Address 428 to listen, send string.
110 RD\$=SPACE\$(100)	Define reading input buffer.
120 CALL IBRD(M428%,RD\$)	Address 428 to talk, get reading.
130 PRINT RD\$	Display the string.
140 GOTO 70	Repeat.
150 V%=0:CALL IBONL(M428%,V%)	Close the instrument file.
160 CALL IBONL(BRD0%,V%)	Close the board file.
170 END	

Hewlett-Packard Model 9000 Series 200/300

Introduction

The following program sends a command string to the Model 428 from a Hewlett-Packard Model 9000 Series 200/300 computer and displays the response on the computer CRT. The computer must be equipped with HP BASIC 4.0.

Directions

1. Using the front panel MENU key, set the primary IEEE-488 address of the Model 428 to 22.
2. With the power off, connect the Model 428 to the IEEE-488 interface card installed in the HP computer.
3. Enter the lines in the program below, using the ENTER/RETURN key after each line.
4. Press the RUN key and type in the desired command string at the COMMAND STRING prompt. For example, to view the instrument model number and firmware revision, type in U4X and press the ENTER/RETURN key. The Model 428 firmware revision, (e.g. 428A01) will then appear on the computer display. The suppress value will be displayed if you send a command other than U.

PROGRAM	COMMENTS
10 DIM A\$(50),B\$(50)	
20 REMOTE 722	! Place 428 in remote.
30 LINPUT "COMMAND STRING:",A\$! Prompt for and input command.
40 OUTPUT 722;A\$! Address 428 to listen, send string.
50 ENTER 722;B\$! Address 428 to talk, input response.
60 PRINT B\$! Display response string.
70 GOTO 30	! Repeat
80 END	

APPENDIX E

IEEE-488 Bus Overview

Introduction

Basically, the IEEE-488 bus is simply a communication system between two or more electronic devices. A device can be either an instrument or a computer. When a computer is used on the bus, it serves to supervise the communication exchange between all the devices and is known as the controller. Supervision by the controller consists of determining which device will talk and which device will listen. As a talker, a device will output information and as a listener, a device will receive information. To simplify the task of keeping track of the devices, a unique address number is assigned to each one.

On the bus, only one device can talk at a time and is addressed to talk by the controller. The device that is talking is known as the active talker. The devices that need to listen to the talker are addressed to listen by the controller. Each listener is then referred to as an active listener. Devices that do not need to listen are instructed to unlisten. The reason for the unlisten instruction is to optimize the speed of bus information transfer since the task of listening takes up bus time.

Through the use of control lines, a handshake sequence takes place in the transfer process of information from a talker to a listener. This handshake sequence helps ensure the credibility of the information transfer. The basic handshake sequence between an active controller (talker) and a listener is as follows:

1. The listener indicates that it is ready to listen.
2. The talker places the byte of data on the bus and indicates that the data is available to the listener.
3. The listener, aware that the data is available, accepts the data and then indicates that the data has been accepted.
4. The talker, aware that the data has been accepted, stops sending data and indicates that data is not being sent.
5. The listener, aware that there is no data on the bus, indicates that it is ready for the next byte of data.

Bus Description

The IEEE-488 bus, which is also frequently referred to as the GPIB (General Purpose Interface Bus), was designed as a parallel transfer medium to optimize data transfer without using an excessive number of bus lines. In keeping with this goal, the bus has only eight data lines that are used for both data and with most commands. Five bus management lines and three handshake lines round out the complement of bus signal lines.

A typical set up for controlled operation is shown in Figure E-1. Generally, a system will contain one controller and a number of other instruments to which the commands are given. Device operation is categorized into three operators: controller, talker and listener. The controller does what its name implies; it controls the instruments on the bus. The talker sends data while a listener receives data. Depending on the type of instrument, any particular device can be a talker only, a listener only or both a talker and listener.

There are two categories of controllers: system controller, and basic controller. Both are able to control other instruments, but only the system controller has the absolute authority in the system. In a system with more than one controller, only one controller may be active at any given time. Certain protocol is used to pass control from one controller to another.

The IEEE-488 bus is limited to 15 devices, including the controller. Thus, any number of talkers and listeners up to that limit may be present on the bus at one time. Although several devices may be commanded to listen simultaneously, the bus can have only one active talker, or communications would be scrambled.

A device is placed in the talk or listen state by sending an appropriate talk or listen command. These talk and listen commands are derived from an instrument's primary address. The primary address may have any value between 0 and 31, and is generally set by rear panel DIP switches or programmed in from the front panel of the instrument. The actual listen address value sent out over the bus is obtained by ORing the primary address with \$20. For exam-

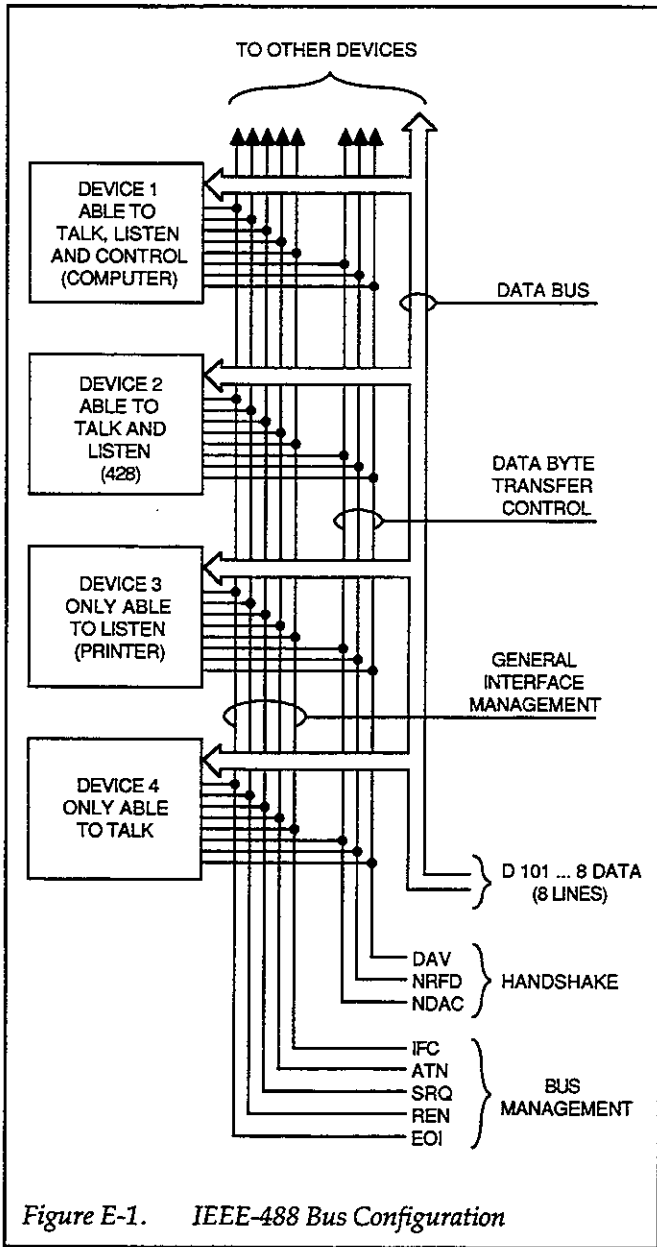

Figure E-1. IEEE-488 Bus Configuration

ple, if the primary address is 22 decimal (\$16), the actual listen address is \$36 (\$36 = \$16 + \$20). In a similar manner, the talk address is obtained by ORing the primary address with \$40. With the present example, the talk address derived from a primary address of 22 decimal would be \$56 (\$56 = \$16 + \$40).

The IEEE-488 standards also include another addressing mode called secondary addressing. Secondary addresses lie in the range of \$60-\$7F. Note, however, that many devices, including the Model 428, do not use secondary addressing.

Once a device is addressed to talk or listen, the appropriate bus transactions take place. For example: if the instrument is addressed to talk, it places its data string on the bus one byte at a time. The controller reads the information and the appropriate software can be used to direct the information to the desired location.

Bus Lines

The signal lines on the IEEE-488 bus are grouped into three different categories: data lines, management lines and handshake lines. The data lines handle bus data and commands, while the management and handshake lines ensure that proper data transfer and operation takes place. Each bus line is active low, with approximately zero volts representing a logic 1 (true). The following paragraphs describe the operation of these lines.

Data Lines

The IEEE-488 bus uses eight data lines that transfer data one byte at a time. DIO1 (Data Input/Output) through DIO8 (Data Input/Output) are the eight data lines used to transmit both data and multiline commands and are bidirectional. The data lines operate with low true logic.

Bus Management Lines

The five bus management lines help to ensure proper interface control and management. These lines are used to send the uniline commands.

ATN (Attention) — The ATN line is one of the more important management lines in that the state of this line determines how information on the data bus is to be interpreted.

IFC (Interface Clear) — As the name implies, the IFC line controls clearing of instruments from the bus.

REN (Remote Enable) — The REN line is used to place the instrument on the bus in the remote mode.

EOI (End or Identify) — The EOI is usually used to mark the end of a multi-byte data transfer sequence.

SRQ (Service Request) — This line is used by devices when they require service from the controller.

Handshake Lines

The bus handshake lines that operate in an interlocked sequence. This method ensures reliable data transmission regardless of the transfer rate. Generally, data transfer will occur at a rate determined by the slowest active device on the bus.

One of the three handshake lines is controlled by the source (the talker sending information), while the remaining two lines are controlled by accepting devices (the listener or listeners receiving the information). The three handshake lines are:

DAV (DATA VALID) — The source controls the state of the DAV line to indicate to any listening devices whether or not data bus information is valid.

NRFD (Not Ready For Data) — The acceptor controls the state of NRFD. It is used to signal to the transmitting device to hold off the byte transfer sequence until the accepting device is ready.

NDAC (Not Data Accepted) — NDAC is also controlled by the accepting device. The state of NDAC tells the source whether or not the device has accepted the data byte.

The complete handshake sequence for one data byte is shown in Figure E-2. Once data is placed on the data lines, the source checks to see that NRFD is high, indicating that all active devices are ready. At the same time, NDAC should be low from the previous byte transfer. If these conditions are not met, the source must wait until NDAC and NRFD have the correct status. If the source is a controller, NRFD and NDAC must be stable for at least 100nsec after ATN is set true. Because of the possibility of a bus hang up, many controllers have time-out routines that display messages in case the transfer sequence stops for any reason.

Once all NDAC and NRFD are properly set, the source sets DAV low, indicating to accepting devices that the byte on the data lines is now valid. NRFD will then go low, and NDAC will go high once all devices have accepted the data. Each device will release NDAC at its own rate, but NDAC will not be released to go high until all devices have accepted the data byte.

The sequence just described is used to transfer both data, talk and listen addresses, as well as multiline commands. The state of the ATN line determines whether the data bus contains data, addresses or commands as described in the following paragraph.

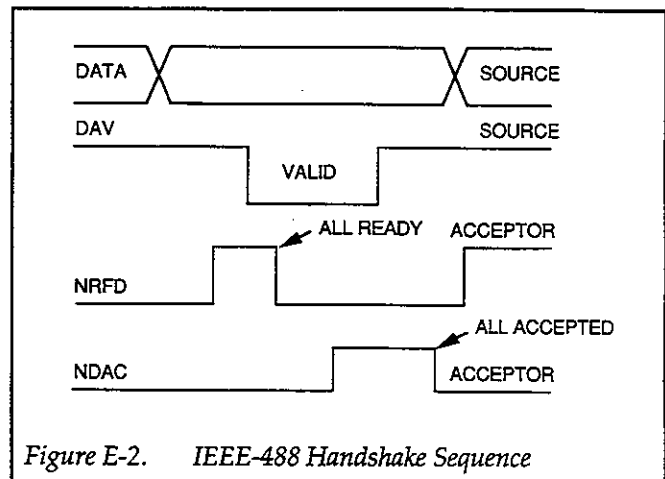

Figure E-2. IEEE-488 Handshake Sequence

Bus Commands

The instrument may be given a number of special bus commands through the IEEE-488 interface. This section briefly describes the purpose of the bus commands which are grouped into the following three categories.

1. **Uniline Commands** - Sent by setting the associated bus lines true. For example, to assert REN (Remote Enable), the REN line would be set low (true).
2. **Multiline Commands** - General bus commands which are sent over the data lines with the ATN line true (low).
3. **Device-dependent Commands** - Special commands whose meanings depend on device configurations; sent with ATN high (false).

These bus commands and their general purpose are summarized in Table E-1.

Uniline Commands

ATN, IFC and REN are asserted only by the controller. SRQ is asserted by an external device. EOI may be asserted either by the controller or other devices depending on the direction of data transfer. The following is a description of each command. Each command is sent by setting the corresponding bus line true.

Table E-1. IEEE-488 Bus Command Summary

Command Type	Command	State of ATN Line*	Comments
Uniline	REN (Remote Enable)	X	Sets up devices for remote operation. Marks end of transmission. Clears interface Defines data bus contents. Controlled by external device.
	EOI	X	
	IFC (Interface Clear)	X	
	ATN (Attention)	Low	
Multiline Universal	LLO (Local Lockout)	Low	Locks out local operation. Returns device to default conditions.
	DCL (Device Clear)	Low	
Addressed	SPE (Serial Enable)	Low	Enables serial polling. Disables serial polling. Returns unit to default conditions.
	SPD (Serial Poll Disable)	Low	
	SDC (Selective Device Clear)	Low	
Unaddressed	GTL (Go To Local)	Low	Returns device to local. Removes all listeners from bus. Removes any talkers from bus.
	UNL (Unlisten)	Low	
	UNT (Untalk)	Low	
Device-dependent		High	Programs Model 428 for various modes.

* X = Don't Care

REN (Remote Enable) — REN is sent to set up instruments on the bus for remote operation. When REN is true, devices will be removed from the local mode. Depending on device configuration, all front panel controls except the LOCAL button (if the device is so equipped) may be locked out when REN is true. Generally, REN should be sent before attempting to program instruments over the bus.

EOI (End or Identify) — EOI is used to positively identify the last byte in a multi-byte transfer sequence, thus allowing data words of various lengths to be transmitted easily.

IFC (Interface Clear) — IFC is used to clear the interface and return all devices to the talker and listener idle states.

ATN (Attention) — The controller sends ATN while transmitting addresses or multiline commands.

SRQ (Service Request) — SRQ is asserted by a device when it requires service from a controller.

Universal Multiline Commands

Universal commands are those multiline commands that require no addressing. All devices equipped to implement such commands will do so simultaneously when the commands are transmitted. As with all multiline commands, these commands are transmitted with ATN true.

LLO (Local Lockout) — LLO is sent to the instrument to lock out the LOCAL key and thus all their front panel controls.

DCL (Device Clear) — DCL is used to return instruments to some default state. Usually, instruments return to their power-up conditions.

SPE (Serial Poll Enable) — SPE is the first step in the serial polling sequence which is used to determine which device has requested service.

SPD (Serial Poll Disable) — SPD is used by the controller to remove all devices on the bus from the serial poll mode and is generally the last command in the serial polling sequence.

Addressed Multiline Commands

Addressed commands are multiline commands that must be preceded by the device listen address before that instrument will respond to the command in question. Note that only the addressed device will respond to these commands. Both the commands and the address preceding it are sent with ATN true.

SDC (Selective Device Clear) — The SDC command performs essentially the same function as the DCL command except that only the addressed device responds. Generally, instruments return to their power-up default conditions when responding to the SDC command.

GTL (Go To Local) — The GTL command is used to remove instruments from the remote mode. With some instruments, GTL also unlocks front panel controls if they were previously locked out with the LLO command.

GET (Group Execute Trigger) — The GET command is used to trigger devices to perform a specific action that depends on device configuration (for example, take a reading). Although GET is an addressed command, many devices respond to GET without addressing.

Address Commands

Addressed commands include two primary command groups and a secondary address group. ATN is true when these commands are asserted. The commands include:

LAG (Listen Address Group) — These listen commands are derived from an instrument's primary address and are used to address devices to listen. The actual command byte is obtained by ORing the primary address with \$20.

TAG (Talk Address Group) — The talk commands are derived from the primary address by ORing the address with \$40. Talk commands are used to address devices to talk.

SCG (Secondary Command Group) — Commands in this group provide additional addressing capabilities. Many devices (including the Model 428) do not use these commands.

Unaddress Commands

The two unaddress commands are used by the controller to remove any talkers or listeners from the bus. ATN is true when these commands are asserted.

UNL (Unlisten) — Listeners are placed in the listener idle state by the UNL command.

UNT (Untalk) — Any previously commanded talkers will be placed in the talker idle state by the UNT command.

Device-dependent Commands

The purpose of the device-dependent commands will depend on the configuration of the instrument. Generally, these commands are sent as one or more ASCII characters that tell the device to perform a specific function.

The IEEE-488 bus actually treats these commands as data in that ATN is false when the commands are transmitted.

Command Codes

Command codes for the various commands that use the data lines are summarized in Figure E-3. Hexadecimal and the decimal values for the various commands are listed in Table E-2.

Table E-2. Hexadecimal and Decimal Command Codes

Command	Hex Value	Decimal Value
GTL	01	1
SDC	04	4
GET	08	8
LLO	11	17
DCL	14	20
SPE	18	24
SPD	19	25
LAG	20-3F	32-63
TAG	40-5F	64-95
SGG	60-7F	96-127
UNL	3F	63
UNT	5F	95

In particular, the correct listen address must be sent to the instrument before it will respond to addressed commands. Table E-3 lists a typical bus sequence for sending the addressed multiline commands. In this instance, the SDC command is being sent to the instrument. UNL is generally sent as part of the sequence to ensure that no other active listeners are present. Note that ATN is true for both the listen command and the SDC command byte itself.

Table E-4 gives a typical device-dependent command sequence. In this instance, ATN is true while the instrument is being addressed, but it is set high while sending the device-dependent command string.

Typical Command Sequences

For the various multiline commands, a specific bus sequence must take place to properly send the command.

IEEE Command Groups

Command groups supported by the Model 428 are listed in Table E-5. Device-dependent commands are not included in this list.

Table E-3. Typical Addressed Command Sequence

Step	Command	ATN State	Data Bus		
			ASCII	Hex	Decimal
1	UNL	Set low	?	3F	63
2	LAG*	Stays low	0	36	54
3	SDC	Stays low	EOT	04	4
4		Returns high			

*Assumes primary address = 22.

Table E-4. Typical Device-dependent Command Sequence

Step	Command	ATN State	Data Bus		
			ASCII	Hex	Decimal
1	UNL	Set low	?	3F	63
2	LAG*	Stays low	0	36	54
3	Data	Set high	F	52	82
4	Data	Stays high	0	30	48
5	Data	Stays high	X	58	88

*Assumes primary address = 22.

Table E-5. IEEE Command Groups

HANDSHAKE COMMAND GROUP	
	NDAC = NOT DATA ACCEPTED
	NRFD = NOT READY FOR DATA
	DAV = DATA VALID
UNIVERSAL COMMAND GROUP	
	ATN = ATTENTION
	DCL = DEVICE CLEAR
	IFC = INTERFACE CLEAR
	REN = REMOTE ENABLE
	SPD = SERIAL POLL DISABLE
	SPE = SERIAL POLL ENABLE
ADDRESS COMMAND GROUP	
LISTEN:	LAG = LISTEN ADDRESS GROUP
	MLA = MY LISTEN ADDRESS
	UNL = UNLISTEN
TALK:	TAG = TALK ADDRESS GROUP
	MTA = MY TALK ADDRESS
	UNT = UNTALK
	OTA = OTHER TALK ADDRESS
ADDRESSED COMMAND GROUP	
	ACG = ADDRESSED COMMAND GROUP
	GTL = GO TO LOCAL
	SDC = SELECTIVE DEVICE CLEAR
STATUS COMMAND GROUP	
	RQS = REQUEST SERVICE
	SRQ = SERIAL POLL REQUEST
	STB = STATUS BYTE
	EOI = END

APPENDIX F

Typical Response Curves

Typical response curves with sinusoidal inputs for various gain and rise time settings are included on the following pages.

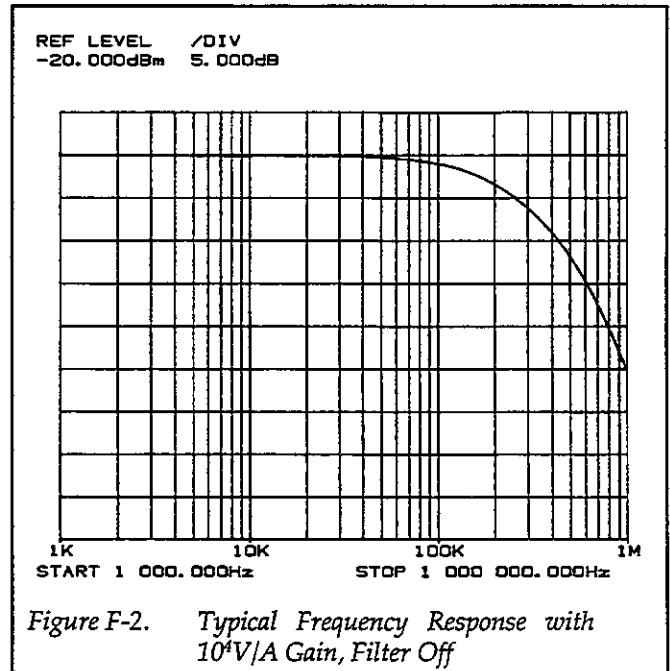
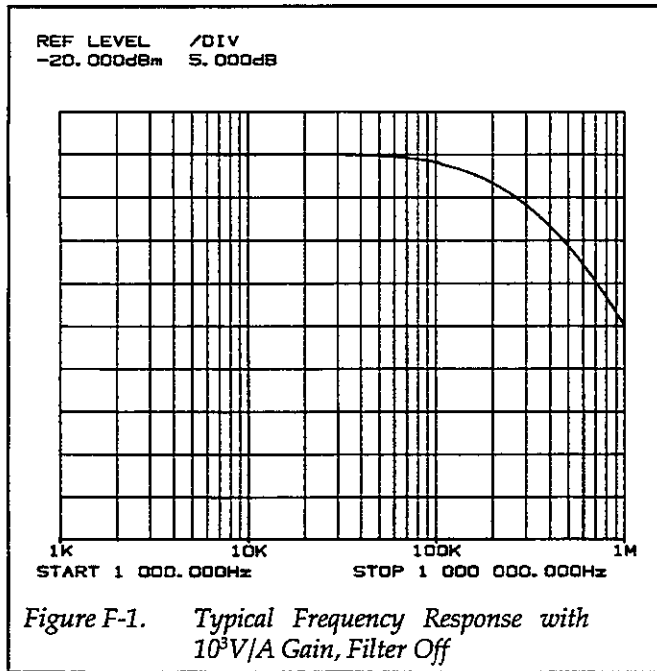

APPENDIX F
Typical Response Curves

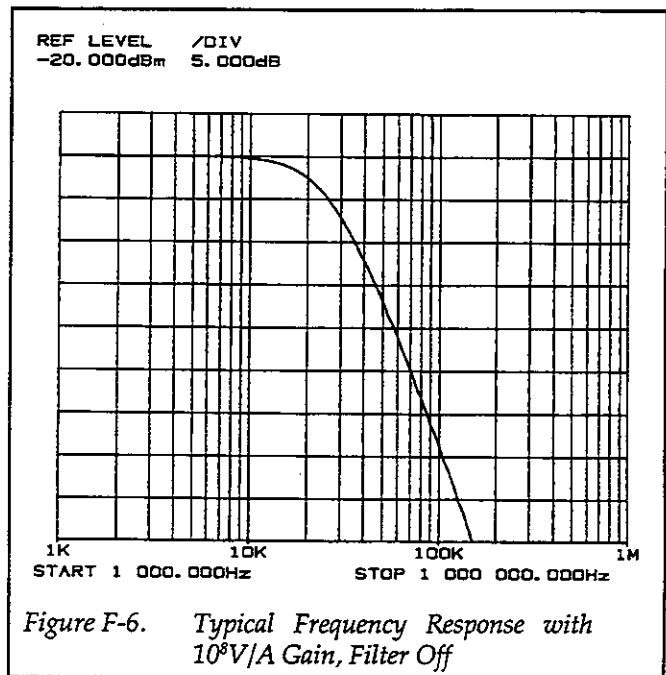
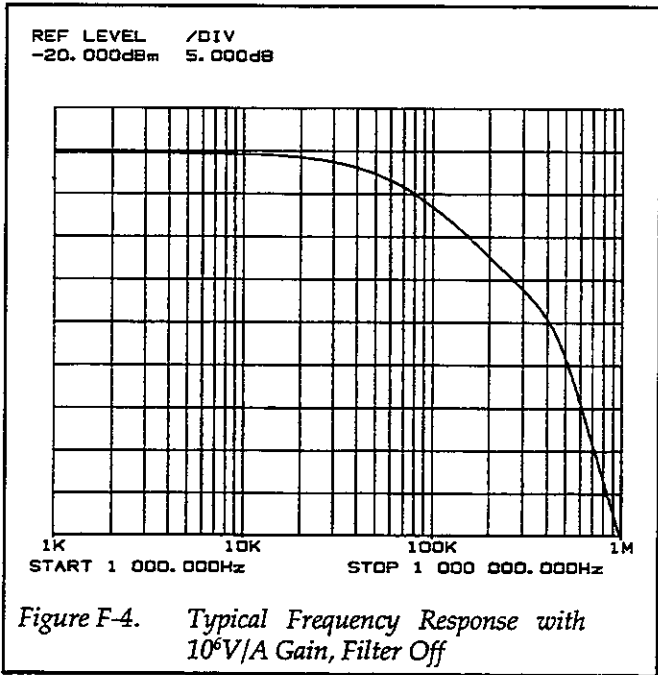
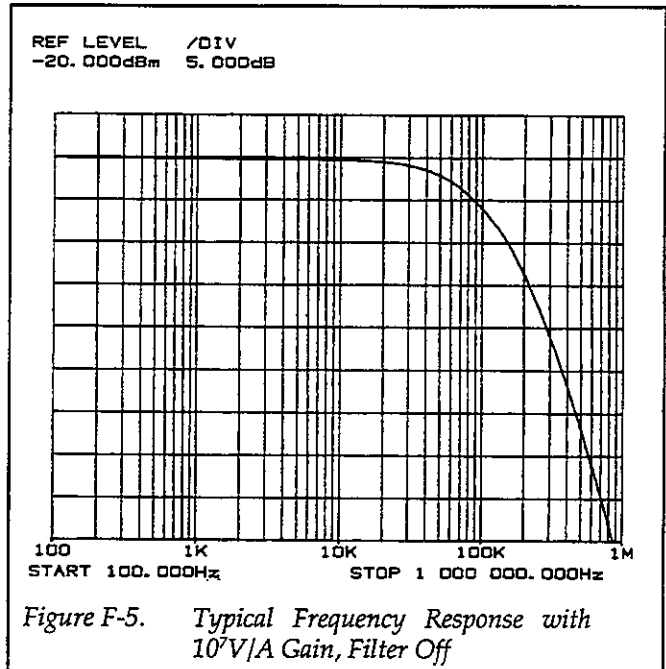
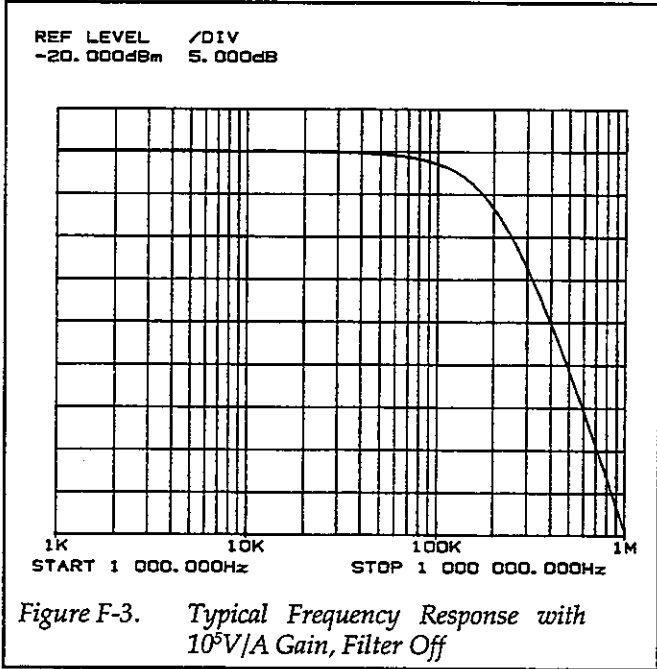

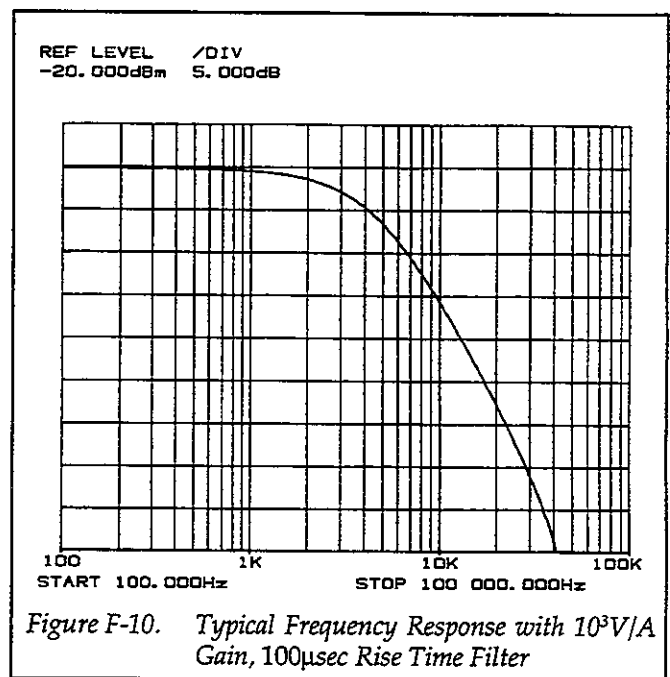
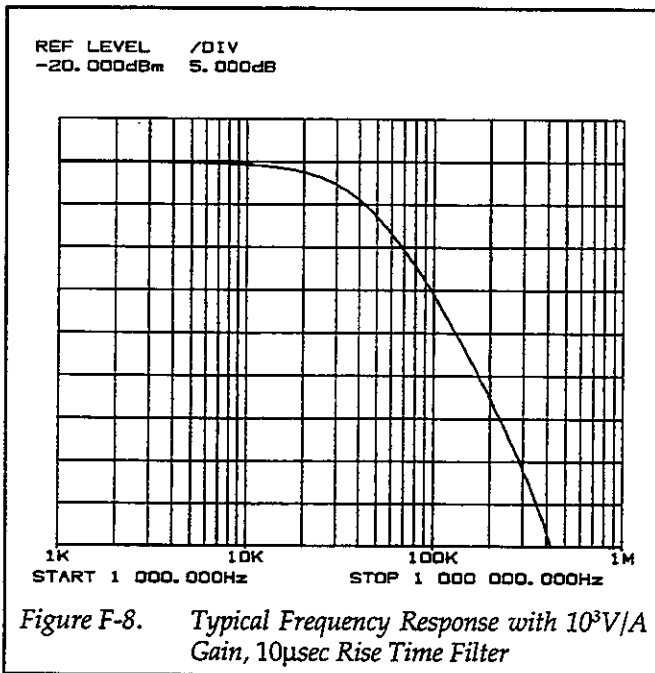
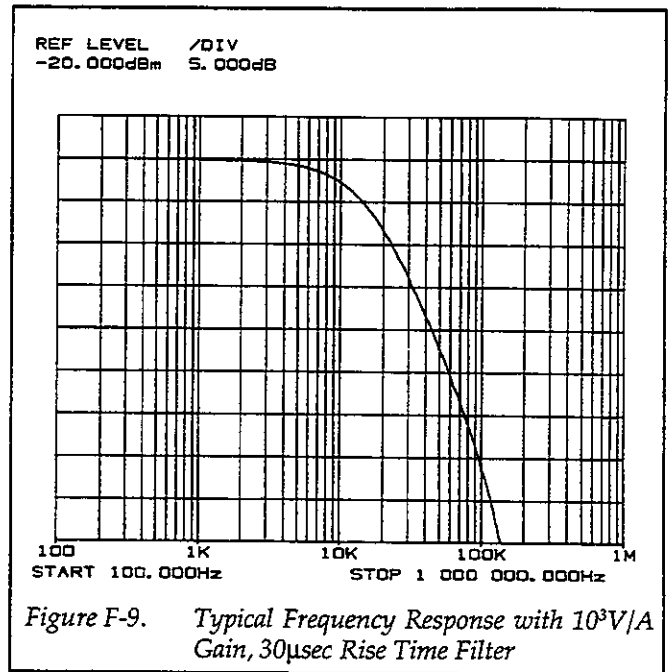
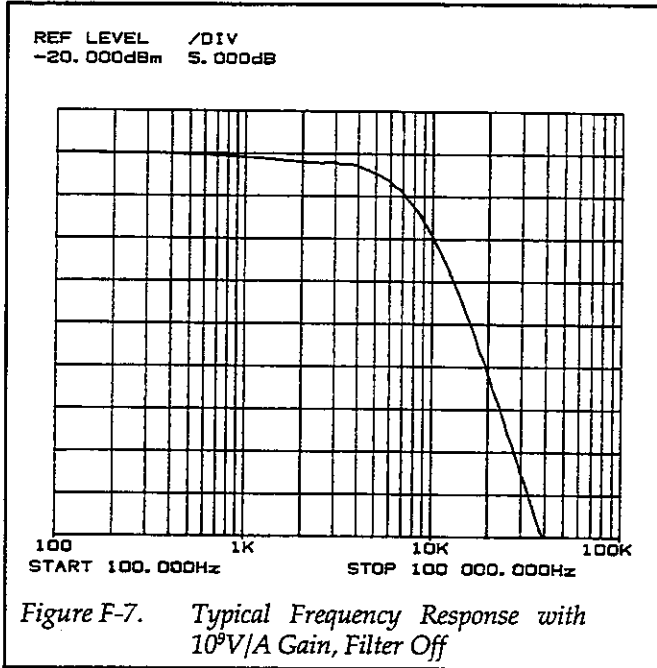

APPENDIX F
Typical Response Curves

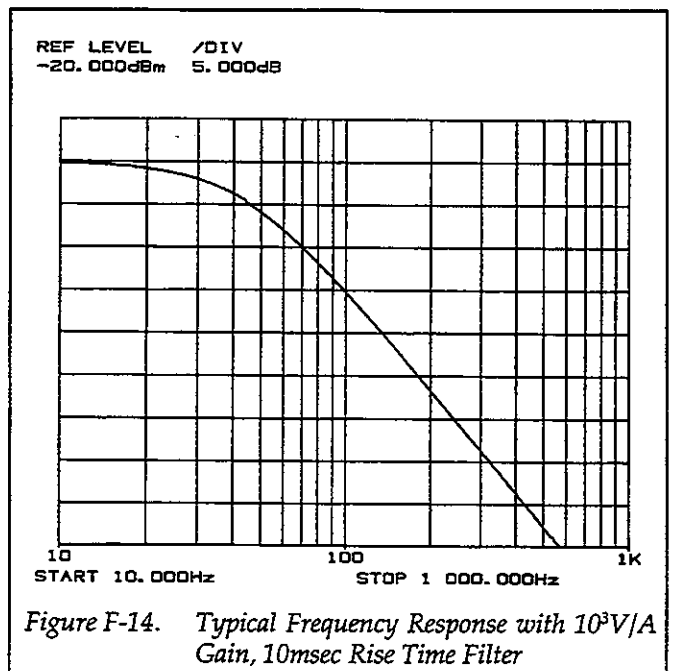
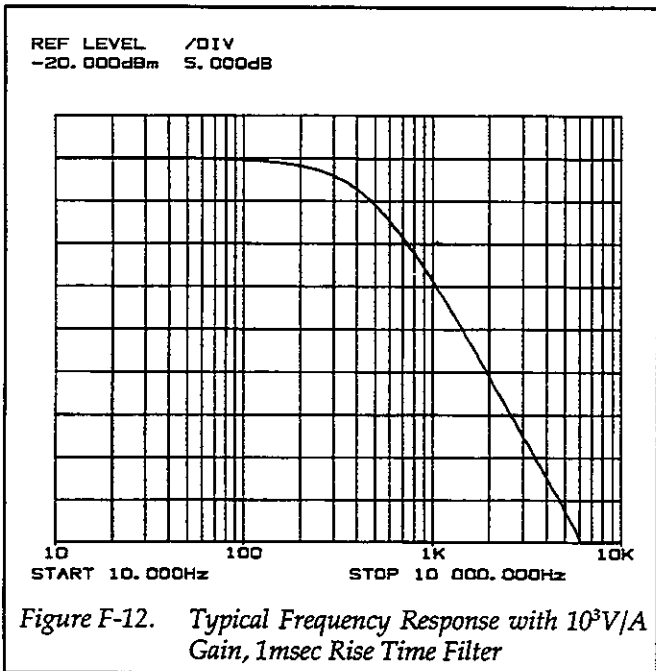
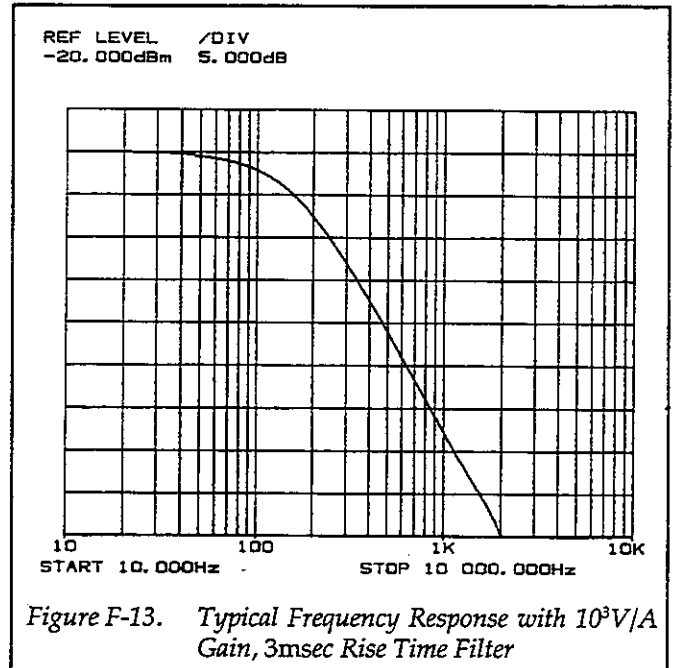
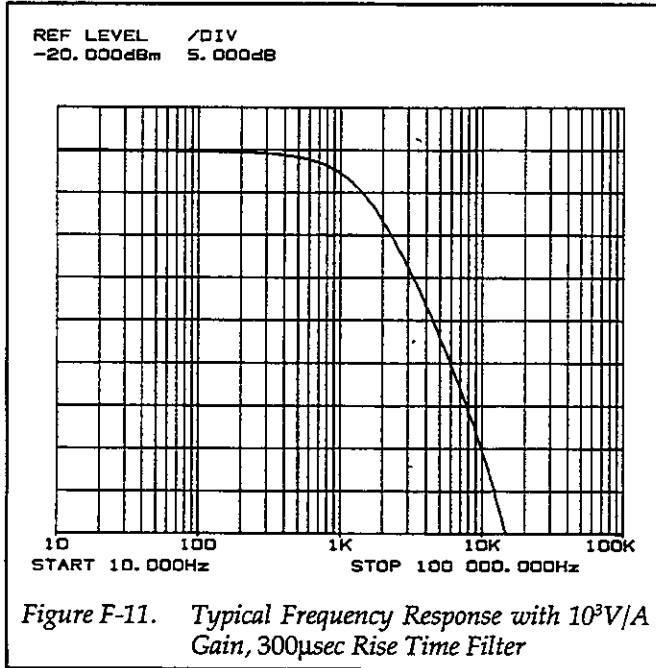

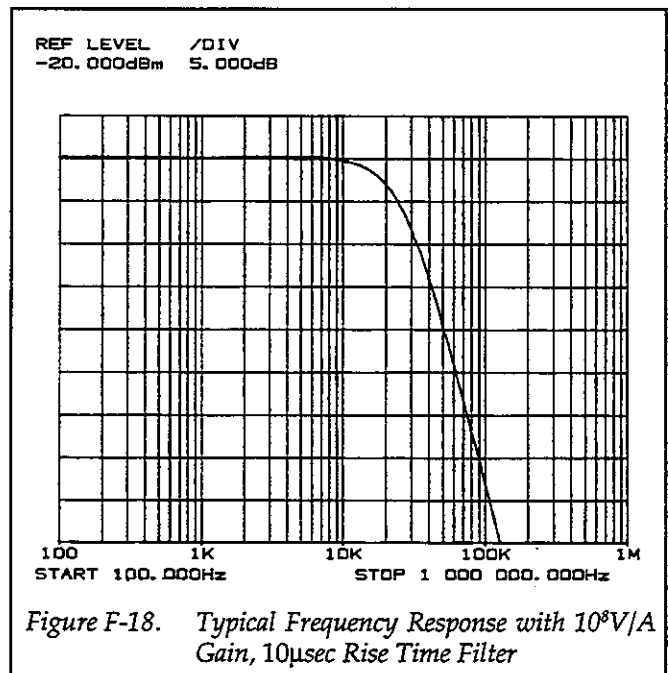
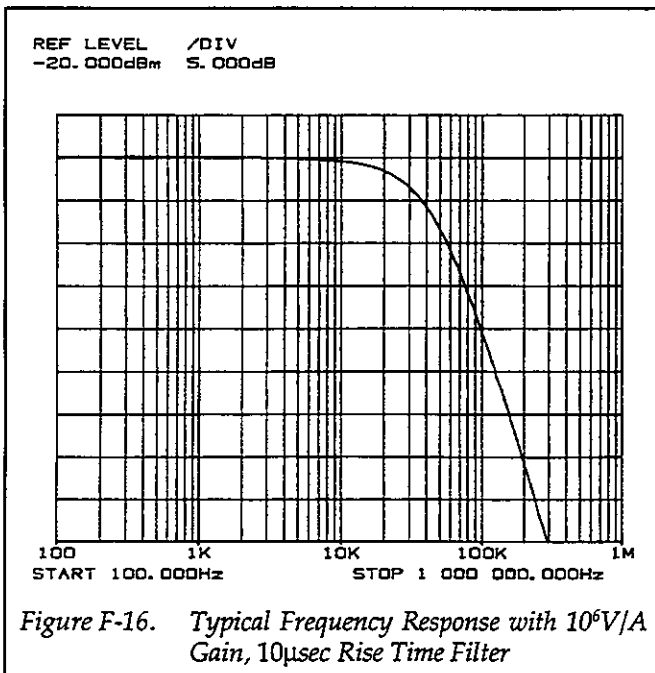
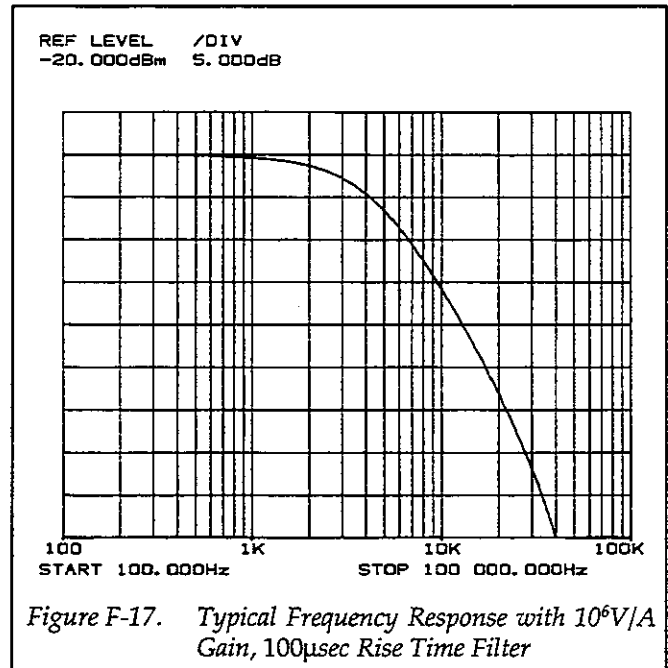
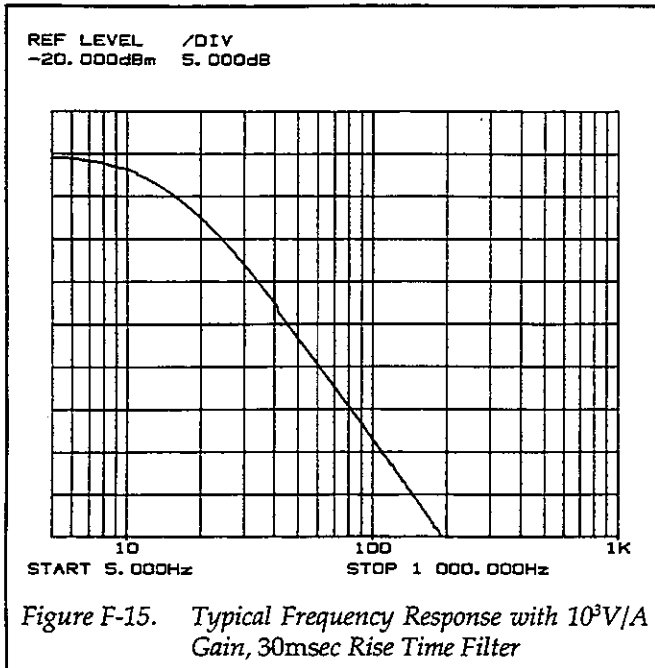

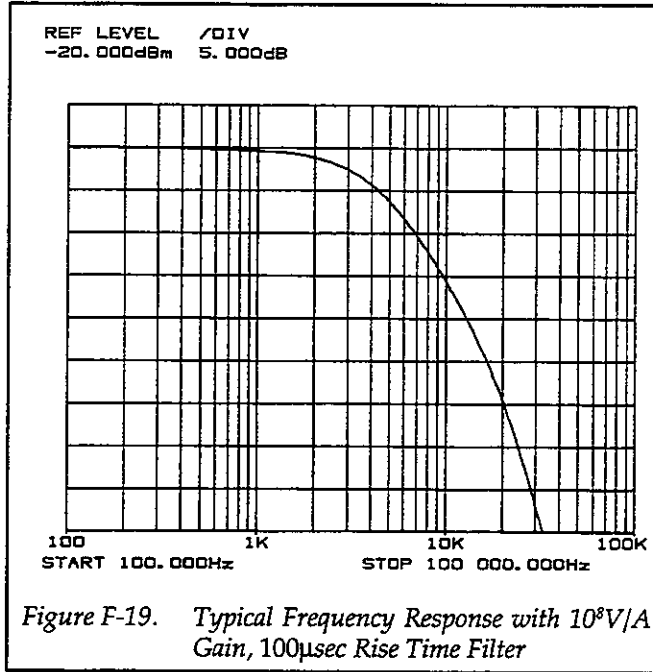

APPENDIX G

Bus Hold-off Times

Table G-1. Typical Bus Hold-off Times

Description	Command	Time 1	Time 2
Display Intensity	A1	5.786msec	
	A2	5.540msec	
Bias Voltage	B1	16.42msec	366.2msec
Zero Check	C0	125.3msec	474.5msec
Zero Correct	C2	1.898sec	2.028sec
Display Message	DK	3.517msec	
	DKEITHLEY	4.378msec	
Selftest	J0	1.929sec	
	J1	14.45sec	
EOI and X hold off	K0	4.035msec	
	K1	5.668msec	
	K2	5.422msec	
	K3	5.432msec	
Default Factory	L0	473.2msec	
	L1	130.6msec	
	L2	382.4msec	
SRQ Mask	M3	5.668msec	
	M35	5.914msec	
	M32, M64	5.883msec	
Suppression	N1	16.96msec	366.7msec
	CON2	2.579sec	2.928msec
Filter	P1	17.43msec	366.0msec
Gain Select (x10 on, "W1")	R4	16.64msec	366.3msec
	R8	16.41msec	366.0msec
	R10	31.38msec	381.4msec
Suppression value (suppression on, "N1")	S5.1E-3, 0	17.61msec	367.7msec
	S5.1E-3, 0	30.41msec	380.4msec
	S-2.45E-5, 6	21.38msec	370.9msec
	S69E-10, 2	19.10msec	369.0msec
Filter rise time	T4	16.50msec	

Typical Bus Hold-off Times Cont.

Description	Command	Time 1	Time 2
Alternate output	U	3.384msec	
	U0	3.988msec	
	U1, U2, U3	5.371msec	
	U4	5.652msec	
Bias value	V+5.00	17.41msec	367.0msec
	V-3.769	17.59msec	367.7msec
(bias on, "B1")	V+5.00	174.0msec	373.9msec
(bias on, "B1")	V-3.769	174.7msec	374.9msec
X10 multiplexer	W1	31.46msec	381.4msec
Execute	X	2.862msec	
Terminator	Y0	3.983msec	
	Y1	5.371msec	
	Y2	5.612msec	
	Y3	5.565msec	
Automatic filtering	Z0	14.68msec	365.0msec

Time 1 Commands were executed from factory default configuration.

Time 2 Commands were executed from factory default configuration with the filter on and rise time set to 300msec.

APPENDIX H

Effective Noise Current

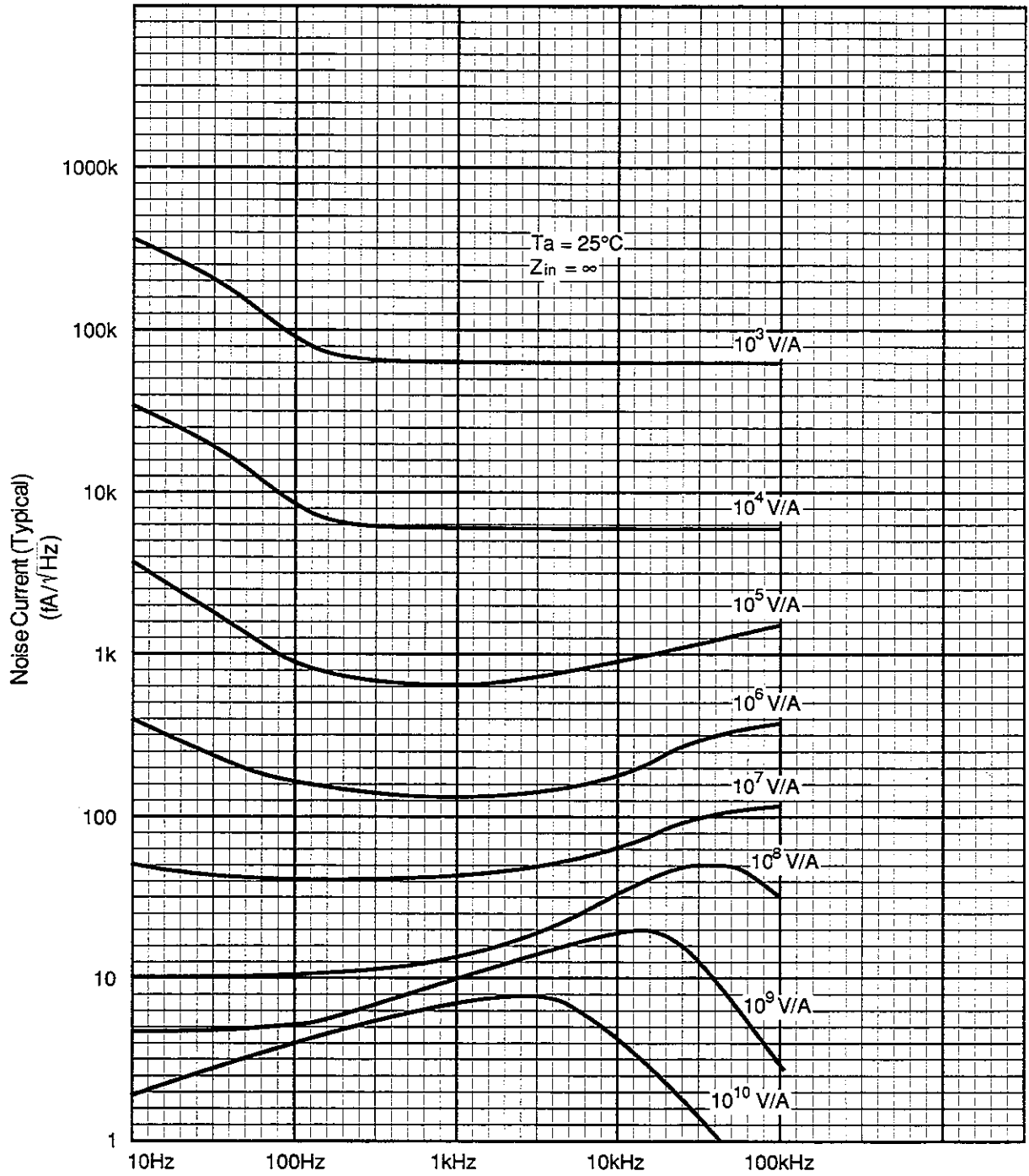

Figure H-1. Effective Noise Current

INDEX

Symbols

+15V Supplies, 6-23
+5V Supply, 6-23
+6.5V Supply, 6-23

A

AC Line Input, 6-23
ACCESSORIES, 1-2
ADJUSTMENTS, 7-2
Adjust Knob, 3-8
Adjustment Locations, 7-4
ANALOG CIRCUITS, 6-1
Analog Circuitry Checks, 7-12
Analog Control, 6-15
APPLICATIONS, 3-25
ASCII Character Codes, C-1
Auto-Filter, 3-11, 3-20
Auto-Filter On/Off, 4-33
Auto-Suppression, 3-11
AVAILABLE MODELS, 1-1

B

BLOCK DIAGRAM, 6-1
BUS CONNECTIONS, 4-38
Bus Hold-off Times, G-1
Bus Limitations, 4-39

C

Cable Capacitance, 3-4
Cable Noise Currents, 3-23
Circuit Board Removal, 7-9
COMPONENT LAYOUTS AND SCHEMATIC DIAGRAMS, 8-1
Command Syntax, 4-1
Comparator Checks, 7-13
Contact Designations, 4-39
Controller Programs, D-1
Cover Removal, 7-7
CURRENT SUPPRESSION, 3-10
Current Suppression, 6-10
Current Suppression Accuracy, 5-5
Current Suppression Value and Range, 4-21
Current Waveform Acquisition, 3-28
Current-to-Voltage Conversion Polarity, 3-4
Cursor Key, 3-8

D

DATA ENTRY, 3-8
DCL (Device Clear), 4-35
DEVICE-DEPENDENT COMMAND PROGRAMMING, 4-1
Default and Alternate Output, 4-24
Default Conditions, 3-2

Device-dependent Command Summary, 4-2, 4-3, A-1
DIGITAL CIRCUITS, 6-17
DISASSEMBLY, 7-7
DISPLAY INTENSITY, 3-21
DISPLAY MESSAGES, 3-2
Differential Amplifier, 6-8
Digital Block Diagram, 6-17
Digital Circuitry Checks, 7-11
Display Error Messages, 3-3
Display Intensity, 4-7
Display Message, 4-10
Display/Keyboard, 6-21

E

ENVIRONMENTAL CONDITIONS, 5-1
EOI and Bus Hold-Off, 4-13
Error Status Word, 4-25
Execute, 4-31
Exploded View, 7-8

F

FACTORY SERVICE, 8-1
FEATURES, 1-1
FILTER, 3-11
Filter, 6-9
Filter On/Off, 4-19
Filter Phase and Delay Characteristics, 3-13
Filter Response, 3-12
Filter Rise Time, 3-11, 4-23
FRONT AND REAR PANEL CONFIGURATION, 2-1
FRONT PANEL OPERATION, 2-4
Frequency Response, 3-12
Front Panel, 2-2
Front Panel Messages, 4-36
Front Panel Operation, 3-1
Front Panel Removal, 7-7

G

GAIN, 3-9
GAIN RESISTOR REPLACEMENT, 7-14
Gain Accuracy, 5-2
GENERAL BUS COMMANDS, 4-34
General Information, 1-1
Getting Started, 2-1
Ground Loops, 3-24
GTL (Go To Local) and Local, 4-35

H

HANDLING AND CLEANING PRECAUTIONS, 7-1
High-Speed Capacitor Leakage Tests, 3-25
Hit Button, 4-11

I

IDDC, 4-37
IDDCO, 4-37
IEEE-488 Bus Overview, E-1
IEEE-488 Indicators, 4-38
IEEE-488 Interface, 6-22
IEEE-488 OPERATION, 2-5
IEEE-488 Primary Address, 3-19
IEEE-488 Reference, 4-1
IFC (Interface Clear), 4-34
Input Amplifier, 6-4
Input Connections, 3-4, 3-5
Interface Function Codes, B-1
Invalid Commands, 4-2

L

Leakage Resistance, 3-23
LINE FUSE REPLACEMENT, 7-1
Line Power, 3-1
Line Voltage, 3-1
LLO (Local Lockout), 4-35
LOCAL Key, 4-38

M

Machine Status Word, 4-24
Manual Suppression, 3-10
Maximum Input Current, 3-7
MEASUREMENT CONSIDERATIONS, 3-21
MENU, 3-19
Mechanically-Induced Noise, 3-23
Microcomputer, 6-17
Model Number and Firmware Revision, 4-28
Multiple Commands, 4-1

N

No Remote, 4-37
Normal Display Messages, 3-3

O

Optimum Gain/Filter Selection, 3-17
Order of Command Execution, 4-2, 4-5
Output Connections, 3-4, 3-6
Output Offset Adjustment, 7-4
Overall Frequency Response, 3-13

P

PARTS LIST, 8-1
Performance Verification, 5-1
POWER SUPPLIES, 6-22
POWER-UP, 3-1
Power Supply Checks, 7-10

Power-up Sequence, 3-2
PRIMARY ADDRESS, 4-36

R

Radio Frequency Interference, 3-24
REN (Remote Enable), 4-34
Rear Panel, 2-3
Recommended Cables, 4-38
Replaceable Parts, 8-1
Rise Time Adjustments, 7-5

S

SAFETY SYMBOLS AND TERMS, 1-2
Save/Recall Configuration, 3-20, 4-14
SDC (Selective Device Clear), 4-35
Select Gain, 4-20
Self-test, 3-21, 4-12, 7-9
Serial Poll Byte, 4-15
Service Information, 7-1
Shield Removal, 7-7
Shielding, 3-24
Software Revision, 3-19
Source Capacitance, 3-22
Source Resistance, 3-21
SPE, SPD (Serial Polling), 4-35

SPECIAL HANDLING OF STATIC-SENSITIVE DEVICES, 7-2
SPECIFICATIONS, 1-2
SRQ Mask, 4-15
Suppress Circuit Checks, 7-13
Suppression Error Messages, 3-10
Suppression On/Off, Automatic Suppression, 4-18

T

TEST EQUIPMENT, 5-1
Terminator, 4-32
Theory of Operation, 6-1
Total Gain, 4-27
TROUBLESHOOTING, 7-9
Troubleshooting Procedures, 7-9
Typical Response Curves, F-1

U

Using the Model 428 as a Picoammeter, 3-29

V

VERIFICATION PROCEDURES, 5-2

VOLTAGE BIAS, 3-18
Voltage Bias, 6-13
Voltage Bias Accuracy Check, 5-4
Voltage Bias Circuit Checks, 7-14
Voltage Bias On/Off, 4-8
Voltage Bias Value, 4-27, 4-29

W

WARRANTY, 1-1

X

X10 Gain, 3-9
X10 Gain Accuracy, 5-4
X10 Gain Off/On, 4-30

Z

Zero Check, 3-18
Zero Check and Zero Correct, 4-9
Zero Correct, 3-19
Zero-crossing and Overload Detectors, 6-14



An Interworld Highway, LLC Company



Service Form

Model No. _____ Serial No. _____ Date _____

Name and Telephone No. _____

Company _____

List all control settings, describe problem and check boxes that apply to problem. _____

- | | | |
|--|--|--|
| <input type="checkbox"/> Intermittent | <input type="checkbox"/> Analog output follows display | <input type="checkbox"/> Particular range or function bad; specify |
| <input type="checkbox"/> IEEE failure | <input type="checkbox"/> Obvious problem on power-up | <input type="checkbox"/> Batteries and fuses are OK |
| <input type="checkbox"/> Front panel operational | <input type="checkbox"/> All ranges or functions are bad | <input type="checkbox"/> Checked all cables |

Display or output (check one)

- | | |
|---|--|
| <input type="checkbox"/> Drifts | <input type="checkbox"/> Unable to zero |
| <input type="checkbox"/> Unstable | <input type="checkbox"/> Will not read applied input |
| <input type="checkbox"/> Overload | |
| <input type="checkbox"/> Calibration only | <input type="checkbox"/> Certificate of calibration required |
| <input type="checkbox"/> Data required | |

(attach any additional sheets as necessary)

Show a block diagram of your measurement system including all instruments connected (whether power is turned on or not). Also, describe signal source.

Where is the measurement being performed? (factory, controlled laboratory, out-of-doors, etc.)

What power line voltage is used? _____ Ambient temperature? _____ °F

Relative humidity? _____ Other? _____

Any additional information. (If special modifications have been made by the user, please describe.)

Be sure to include your name and phone number on this service form.