

KEITHLEY

Model 2520 Pulsed Laser Diode Test System
User's Manual



An Interworld Highway, LLC Company

A GREATER MEASURE OF CONFIDENCE

WARRANTY

Keithley Instruments, Inc. warrants this product to be free from defects in material and workmanship for a period of 1 year from date of shipment.

Keithley Instruments, Inc. warrants the following items for 90 days from the date of shipment: probes, cables, rechargeable batteries, diskettes, and documentation.

During the warranty period, we will, at our option, either repair or replace any product that proves to be defective.

To exercise this warranty, write or call your local Keithley representative, or contact Keithley headquarters in Cleveland, Ohio. You will be given prompt assistance and return instructions. Send the product, transportation prepaid, to the indicated service facility. Repairs will be made and the product returned, transportation prepaid. Repaired or replaced products are warranted for the balance of the original warranty period, or at least 90 days.

LIMITATION OF WARRANTY

This warranty does not apply to defects resulting from product modification without Keithley's express written consent, or misuse of any product or part. This warranty also does not apply to fuses, software, non-rechargeable batteries, damage from battery leakage, or problems arising from normal wear or failure to follow instructions.

THIS WARRANTY IS IN LIEU OF ALL OTHER WARRANTIES, EXPRESSED OR IMPLIED, INCLUDING ANY IMPLIED WARRANTY OF MERCHANTABILITY OR FITNESS FOR A PARTICULAR USE. THE REMEDIES PROVIDED HEREIN ARE BUYER'S SOLE AND EXCLUSIVE REMEDIES.

NEITHER KEITHLEY INSTRUMENTS, INC. NOR ANY OF ITS EMPLOYEES SHALL BE LIABLE FOR ANY DIRECT, INDIRECT, SPECIAL, INCIDENTAL OR CONSEQUENTIAL DAMAGES ARISING OUT OF THE USE OF ITS INSTRUMENTS AND SOFTWARE EVEN IF KEITHLEY INSTRUMENTS, INC., HAS BEEN ADVISED IN ADVANCE OF THE POSSIBILITY OF SUCH DAMAGES. SUCH EXCLUDED DAMAGES SHALL INCLUDE, BUT ARE NOT LIMITED TO: COSTS OF REMOVAL AND INSTALLATION, LOSSES SUSTAINED AS THE RESULT OF INJURY TO ANY PERSON, OR DAMAGE TO PROPERTY.

KEITHLEY

Keithley Instruments, Inc.

28775 Aurora Road • Cleveland, Ohio 44139 • 440-248-0400 • Fax: 440-248-6168
1-888-KEITHLEY (534-8453) • www.keithley.com

Sales Offices:	BELGIUM:	Bergensesteenweg 709 • B-1600 Sint-Pieters-Leeuw • 02-363 00 40 • Fax: 02/363 00 64
	CHINA:	Yuan Chen Xin Building, Room 705 • 12 Yumin Road, Dewai, Madian • Beijing 100029 • 8610-8225-1886 • Fax: 8610-8225-1892
	FINLAND:	Tietäjäntie 2 • 02130 Espoo • Phone: 09-54 75 08 10 • Fax: 09-25 10 51 00
	FRANCE:	3, allée des Garays • 91127 Palaiseau Cédex • 01-64 53 20 20 • Fax: 01-60 11 77 26
	GERMANY:	Landsberger Strasse 65 • 82110 Germering • 089/84 93 07-40 • Fax: 089/84 93 07-34
	GREAT BRITAIN:	Unit 2 Commerce Park, Brunel Road • Theale • Berkshire RG7 4AB • 0118 929 7500 • Fax: 0118 929 7519
	INDIA:	1/5 Eagles Street • Langford Town • Bangalore 560 025 • 080 212 8027 • Fax: 080 212 8005
	ITALY:	Viale San Gimignano, 38 • 20146 Milano • 02-48 39 16 01 • Fax: 02-48 30 22 74
	JAPAN:	New Pier Takeshiba North Tower 13F • 11-1, Kaigan 1-chome • Minato-ku, Tokyo 105-0022 • 81-3-5733-7555 • Fax: 81-3-5733-7556
	KOREA:	2FL., URI Building • 2-14 Yangjae-Dong • Seocho-Gu, Seoul 137-888 • 82-2-574-7778 • Fax: 82-2-574-7838
	NETHERLANDS:	Postbus 559 • 4200 AN Gorinchem • 0183-635333 • Fax: 0183-630821
	SWEDEN:	c/o Regus Business Centre • Frosundaviks Allé 15, 4tr • 169 70 Solna • 08-509 04 600 • Fax: 08-655 26 10
	TAIWAN:	13F-3, No. 6, Lane 99 Pu-Ding Road • Hsinchu, Taiwan, R.O.C. • 886-3-572-9077 • Fax: 886-3-572-9031

Model 2520 Pulsed Laser Diode
Test System
User's Manual

©2001, Keithley Instruments, Inc.
All rights reserved.
Cleveland, Ohio, U.S.A.
Third Printing, March 2003
Document Number: 2520-900-01 Rev. C

Manual Print History

The print history shown below lists the printing dates of all Revisions and Addenda created for this manual. The Revision Level letter increases alphabetically as the manual undergoes subsequent updates. Addenda, which are released between Revisions, contain important change information that the user should incorporate immediately into the manual. Addenda are numbered sequentially. When a new Revision is created, all Addenda associated with the previous Revision of the manual are incorporated into the new Revision of the manual. Each new Revision includes a revised copy of this print history page.

Revision A (Document Number 2520-900-01).....	June 2001
Revision B (Document Number 2520-900-01).....	August 2001
Revision C (Document Number 2520-900-01).....	March 2003

The following safety precautions should be observed before using this product and any associated instrumentation. Although some instruments and accessories would normally be used with non-hazardous voltages, there are situations where hazardous conditions may be present.

This product is intended for use by qualified personnel who recognize shock hazards and are familiar with the safety precautions required to avoid possible injury. Read and follow all installation, operation, and maintenance information carefully before using the product. Refer to the manual for complete product specifications.

If the product is used in a manner not specified, the protection provided by the product may be impaired.

The types of product users are:

Responsible body is the individual or group responsible for the use and maintenance of equipment, for ensuring that the equipment is operated within its specifications and operating limits, and for ensuring that operators are adequately trained.

Operators use the product for its intended function. They must be trained in electrical safety procedures and proper use of the instrument. They must be protected from electric shock and contact with hazardous live circuits.

Maintenance personnel perform routine procedures on the product to keep it operating properly, for example, setting the line voltage or replacing consumable materials. Maintenance procedures are described in the manual. The procedures explicitly state if the operator may perform them. Otherwise, they should be performed only by service personnel.

Service personnel are trained to work on live circuits, and perform safe installations and repairs of products. Only properly trained service personnel may perform installation and service procedures.

Keithley products are designed for use with electrical signals that are rated Installation Category I and Installation Category II, as described in the International Electrotechnical Commission (IEC) Standard IEC 60664. Most measurement, control, and data I/O signals are Installation Category I and must not be directly connected to mains voltage or to voltage sources with high transient over-voltages. Installation Category II connections require protection for high transient over-voltages often associated with local AC mains connections. Assume all measurement, control, and data I/O connections are for connection to Category I sources unless otherwise marked or described in the Manual.

Exercise extreme caution when a shock hazard is present. Lethal voltage may be present on cable connector jacks or test fixtures. The American National Standards Institute (ANSI) states that a shock hazard exists when voltage levels greater than 30V RMS, 42.4V peak, or 60VDC are present. **A good safety practice is to expect that hazardous voltage is present in any unknown circuit before measuring.**

Operators of this product must be protected from electric shock at all times. The responsible body must ensure that operators are prevented access and/or insulated from every connection point. In some cases, connections must be exposed to potential human contact. Product operators in these circumstances must be trained to protect themselves from the risk of electric shock. If the circuit is capable of operating at or above 1000 volts, **no conductive part of the circuit may be exposed.**

Do not connect switching cards directly to unlimited power circuits. They are intended to be used with impedance limited sources. NEVER connect switching cards directly to AC mains. When connecting sources to switching cards, install protective devices to limit fault current and voltage to the card.

Before operating an instrument, make sure the line cord is connected to a properly grounded power receptacle. Inspect the connecting cables, test leads, and jumpers for possible wear, cracks, or breaks before each use.

When installing equipment where access to the main power cord is restricted, such as rack mounting, a separate main input power disconnect device must be provided, in close proximity to the equipment and within easy reach of the operator.

For maximum safety, do not touch the product, test cables, or any other instruments while power is applied to the circuit under test. ALWAYS remove power from the entire test system and discharge any capacitors before: connecting or disconnecting ca-

bles or jumpers, installing or removing switching cards, or making internal changes, such as installing or removing jumpers.

Do not touch any object that could provide a current path to the common side of the circuit under test or power line (earth) ground. Always make measurements with dry hands while standing on a dry, insulated surface capable of withstanding the voltage being measured.



The instrument and accessories must be used in accordance with its specifications and operating instructions or the safety of the equipment may be impaired.

Do not exceed the maximum signal levels of the instruments and accessories, as defined in the specifications and operating information, and as shown on the instrument or test fixture panels, or switching card.

When fuses are used in a product, replace with same type and rating for continued protection against fire hazard.

Chassis connections must only be used as shield connections for measuring circuits, NOT as safety earth ground connections.

If you are using a test fixture, keep the lid closed while power is applied to the device under test. Safe operation requires the use of a lid interlock.

If  or  is present, connect it to safety earth ground using the wire recommended in the user documentation.

The  symbol on an instrument indicates that the user should refer to the operating instructions located in the manual.

The  symbol on an instrument shows that it can source or measure 1000 volts or more, including the combined effect of normal and common mode voltages. Use standard safety precautions to avoid personal contact with these voltages.

The **WARNING** heading in a manual explains dangers that might result in personal injury or death. Always read the associated information very carefully before performing the indicated procedure.

The **CAUTION** heading in a manual explains hazards that could damage the instrument. Such damage may invalidate the warranty.

Instrumentation and accessories shall not be connected to humans.

Before performing any maintenance, disconnect the line cord and all test cables.

To maintain protection from electric shock and fire, replacement components in mains circuits, including the power transformer, test leads, and input jacks, must be purchased from Keithley Instruments. Standard fuses, with applicable national safety approvals, may be used if the rating and type are the same. Other components that are not safety related may be purchased from other suppliers as long as they are equivalent to the original component. (Note that selected parts should be purchased only through Keithley Instruments to maintain accuracy and functionality of the product.) If you are unsure about the applicability of a replacement component, call a Keithley Instruments office for information.

To clean an instrument, use a damp cloth or mild, water based cleaner. Clean the exterior of the instrument only. Do not apply cleaner directly to the instrument or allow liquids to enter or spill on the instrument. Products that consist of a circuit board with no case or chassis (e.g., data acquisition board for installation into a computer) should never require cleaning if handled according to instructions. If the board becomes contaminated and operation is affected, the board should be returned to the factory for proper cleaning/servicing.

Table of Contents

1	Getting Started	
	General information	1-2
	Warranty information	1-2
	Contact information	1-2
	Manual addenda	1-2
	Specifications	1-2
	Safety symbols and terms	1-2
	Inspection	1-3
	Options and accessories	1-3
	Signal cables and adapters	1-3
	Interface cables	1-4
	Rack mount kits	1-4
	Product overview	1-5
	Mainframe front and rear panel familiarization	1-6
	Front panel summary	1-6
	Rear panel summary	1-7
	Testhead front and rear panel familiarization	1-9
	Front panel summary	1-9
	Rear panel summary	1-10
	Power-up	1-11
	Line voltage	1-11
	Line power connection	1-11
	Power-up sequence	1-11
	System identification	1-12
	Fuse replacement	1-12
	Display	1-13
	Display format	1-13
	Display example	1-13
	Display units	1-13
	Status and error messages	1-13
	Remote display programming	1-14
	Front panel display tests	1-14
	Default settings	1-14
	Saving and restoring user setups	1-14
	Saving setups	1-14
	Restoring setups	1-15
	Power-on configuration	1-15
	Factory default settings	1-15
	Remote setups	1-17
	Menus	1-17
	Main menu	1-18
	Rules to navigate menus	1-18
	Main operation menus	1-19
	Configuration menus	1-21

2

Connections

Connection precautions	2-2
Testhead preparation	2-3
Testhead mounting	2-3
Testhead connections	2-3
Signal connectors	2-5
Signal connectors	2-5
Triax DETECTOR connectors	2-6
CURRENT OUTPUT and VOLTAGE SENSE connectors	2-6
Interlock connections	2-6
Remote interlock connections	2-6
Key interlock	2-7
Laser diode test connections	2-7
Connecting cables	2-7
Typical connections	2-7
Equivalent circuit	2-8
Polarity considerations	2-8
Connection considerations	2-10

3

Basic Operation

Operation overview	3-2
Laser diode source and measure capabilities	3-2
Laser diode source and measure ranges	3-2
Laser diode source compliance	3-3
Photodiode source and measure capabilities	3-3
Photodiode source and measure ranges	3-4
Basic circuit configuration	3-5
Polarity	3-6
Laser diode current source polarity	3-6
Laser diode voltage measurement polarity	3-7
Detector measurement polarity	3-8
Voltage bias polarity	3-8
Configuring sources	3-9
Editing source values	3-9
Configuring laser diode source	3-10
DC mode	3-10
Pulse mode	3-11
Setting photodiode detector source values	3-11
Configuring measurements	3-12
Configuring laser diode measurements	3-12
Configuring photodiode measurements	3-12
Remote source and measure configuration	3-13
Source and measure configuration commands	3-13
Programming example	3-14

4

Laser Diode Testing

Source and measure configuration menus	4-2
Front panel laser diode testing	4-3
Test circuit configuration	4-3
Front panel test procedure	4-4
Step 1: Configure laser diode measurement function	4-4
Step 2: Configure photodiode detector measurement functions	4-4
Step 3: Configure laser diode current source	4-4
Step 4: Configure photodiode detector voltage bias sources	4-4
Step 5: Configure math functions	4-5
Step 6: Turn source outputs on and trigger readings ...	4-5
Step 7: Observe readings on the display	4-5
Step 8: Turn source outputs off	4-5
Remote laser diode testing	4-5
Laser diode test commands	4-5
Programming example	4-7

5

Source-Measure Concepts

Pulse concepts	5-2
Overview	5-2
Delay-pulse cycle	5-2
Delay phase	5-3
Pulse phase	5-3
Duty cycle	5-3
Front panel pulse parameters	5-4
Fixed mode	5-4
Staircase sweep mode	5-4
Remote pulse parameters	5-6
Fixed mode	5-6
Staircase sweep mode	5-6
Pulse rise and fall times	5-7
Sweep waveforms	5-8
Staircase sweeps	5-8
Custom sweep	5-8
Current source operating boundaries	5-10
Limit lines	5-10
Loading effects	5-10
Data flow	5-12
Basic reading display	5-12
Math function display	5-12
Sweep data storage	5-12

6 Range, Filter, and Math

Range	6-2
Measurement ranges	6-2
Laser diode voltage ranges	6-2
Photodiode detector current ranges	6-2
Maximum readings	6-3
Setting the measurement range	6-3
Source ranging	6-3
Remote range programming	6-3
Range programming example	6-4
Filter	6-4
Averaging filter overview	6-4
Filter configuration	6-5
Filter control	6-5
Remote filter programming	6-5
Filter command	6-5
Filter programming example	6-6
Measurement math functions	6-6
Conductance	6-7
Resistance	6-7
Power	6-7
MX + B	6-7
Delta (remote only)	6-7
Front panel math functions	6-8
Math configuration menu	6-8
Programming math functions	6-8
Remote math functions	6-9
Math function commands	6-9
Math function programming example	6-10

7 Sweep Operation

Sweep types	7-2
Linear staircase sweep	7-2
Logarithmic staircase sweep	7-3
Custom sweep	7-4
Configuring and running a sweep	7-5
Front panel sweep operation	7-5
Configuring a sweep	7-5
Performing sweeps	7-6
Performing a linear staircase sweep	7-6
Performing a log staircase sweep	7-7
Remote sweep operation	7-8
Staircase sweep commands	7-8
Staircase sweep programming example	7-9
Custom sweep commands	7-10
Custom sweep programming example	7-10

8

Triggering

Trigger model (front panel operation)	8-2
Idle layer	8-3
Input triggers	8-3
Delay and pulse phases	8-3
Delay phase	8-3
Pulse phase	8-4
Filtering	8-4
Sweep points	8-4
Counter	8-4
Output trigger	8-4
Bench defaults	8-5
Operation summary	8-5
Trigger link	8-5
Input trigger requirements	8-6
Output trigger specifications	8-6
Configuring triggering	8-7
CONFIGURE TRIGGER menu	8-7
Remote triggering	8-9
Trigger model (remote operation)	8-9
Idle and initiate	8-9
Event detection	8-11
Input triggers	8-11
Delay and pulse phases	8-12
Delay phase	8-12
Pulse phase	8-12
Filtering	8-12
Sweep points	8-12
Counter	8-12
Output trigger	8-13
GPIB defaults	8-13
Operation summary	8-13
Remote trigger commands	8-13
Remote trigger example	8-14

9

Digital I/O Port, Interlocks, and Pulse Sync Output

Digital I/O port	9-2
Port configuration	9-2
Digital output lines	9-2
Start-of-test (SOT) line	9-3
+5V output	9-3
Digital output configuration	9-3
Sink operation	9-3
Source operation	9-4

Controlling digital output lines	9-4
Front panel digital output control	9-4
Remote digital output control	9-5
Interlocks	9-5
Interlock operation	9-6
Interlock status indicator test sequence	9-7
Reading interlock state	9-7
Pulse sync output	9-8
Pulse sync waveform	9-8
Pulse sync connections	9-9

10 Remote Operations

Differences: remote vs. local operation	10-2
Local-to-remote transition	10-2
Remote-to-local transition	10-2
Selecting an interface	10-2
GPIB operation	10-3
GPIB standards	10-3
GPIB connections	10-4
Primary address	10-6
General bus commands	10-6
REN (remote enable)	10-7
IFC (interface clear)	10-7
LLO (local lockout)	10-7
GTL (go to local)	10-7
DCL (device clear)	10-7
SDC (selective device clear)	10-8
GET (group execute trigger)	10-8
SPE, SPD (serial polling)	10-8
Front panel GPIB operation	10-8
Error and status messages	10-8
GPIB status indicators	10-9
REM	10-9
TALK	10-9
LSTN	10-9
SRQ	10-9
LOCAL key	10-9
Programming syntax	10-10
Command words	10-10
Commands and command parameters	10-10
Query commands	10-12
Case sensitivity	10-12
Long-form and short-form versions	10-12
Short-form rules	10-13

Program messages	10-13
Single command messages	10-13
Multiple command messages	10-14
Command path rules	10-14
Using common and SCPI commands in the same message	10-15
Program message terminator (PMT)	10-15
Command execution rules	10-15
Response messages	10-15
Sending a response message	10-15
Multiple response messages	10-15
Response message terminator (RMT)	10-16
Message exchange protocol	10-16
RS-232 interface operation	10-16
Sending and receiving data	10-16
Baud rate	10-16
Data bits and parity	10-17
Terminator	10-17
Flow control (signal handshaking)	10-17
RS-232 connections	10-18
Error messages	10-20
Programming example	10-20

11 Status Structure

Overview	11-2
Status byte and SRQ	11-2
Status register sets	11-2
Queues	11-2
Clearing registers and queues	11-4
Programming and reading registers	11-5
Programming enable registers	11-5
Reading registers	11-6
Status byte and service request (SRQ)	11-7
Status byte register	11-8
Service request enable register	11-8
Serial polling and SRQ	11-9
SPE, SPD (serial polling)	11-9
Status byte and service request commands	11-10
Programming example - set MSS (B6) when error occurs	11-10
Status register sets	11-11
Register bit descriptions	11-11
Standard event register	11-11
Operation event register	11-13
Measurement event register	11-14
Questionable event register	11-16

Condition registers	11-17
Event registers	11-17
Event enable registers	11-18
Programming example - program and read register set	11-19
Queues	11-19
Output queue	11-19
Error queue	11-20
Programming example - read error queue	11-21

12 Common Commands

Command summary	12-2
Command reference	12-3
*IDN? — identification query	12-3
*OPC — operation complete	12-3
*OPC? — operation complete query	12-3
*OPC programming example	12-4
*OPT? — option query	12-4
*SAV <NRf> — save	12-4
*RCL <NRf> — recall	12-4
*SAV, *RCL programming example	12-5
*RST — reset	12-5
*TRG — trigger	12-5
*TRG programming example	12-5
*TST? — self-test query	12-6
*WAI — wait-to-continue	12-6

13 SCPI Signal-Oriented Measurement Commands

Command summary	13-2
Acquiring readings	13-2
FETCH?	13-2
[:SENSe[1]]:DATA[:LATest]?	13-3
[:SENSe2]:DATA[:LATest]?	13-3
[:SENSe3]:DATA[:LATest]?	13-3
READ?	13-3
MEASure?	13-3

14 SCPI Command Reference

Reference tables	14-2
Calculate subsystems	14-14
Select laser diode math function	14-15
FORMat <name>	14-15
Set MX + B parameters	14-15
MBFactor <n>	14-15
MMFactor <n>	14-15
UNITs <name>	14-16

Enable and read math function result	14-16
STATe 	14-16
DATA?	14-17
LATest?	14-17
DISPlay subsystem	14-17
Control display	14-17
ENABle 	14-17
ATTRibutes?	14-18
Read display	14-18
DATA?	14-18
Define :TEXT messages	14-18
DATA <a>	14-18
STATe 	14-19
FORMat subsystem	14-19
Data format	14-19
[:DATA] <type>[,length]	14-19
Data elements	14-22
ELEMents <item list>	14-22
Calculate data elements	14-23
CALCulate <item list>	14-23
TRACe data elements	14-24
TRACe <item list>	14-24
SOURce4 <name>	14-25
Byte order	14-25
BORDer <name>	14-25
Status register format	14-26
SREGister <name>	14-26
OUTPut subsystem	14-27
Turn sources on or off	14-27
[:STATe] 	14-27
Interlock status	14-27
TRIPped?	14-27
SENSe subsystem	14-27
Select laser diode voltage measurement range	14-28
[:UPPer] <n>	14-28
Select detector current measurement range	14-28
[:UPPer] <n>	14-28
Select polarity	14-29
POLarity <name>	14-29
Query voltage limit	14-29
TRIPped?	14-29
Query latest readings	14-30
[:LATest]?	14-30
Configure and control filter	14-30
COUNT <n>	14-30
[:STATe] 	14-31

Abort sweep	14-31
:CABort[:LEVel] <n>	14-31
:CABort:STATe 	14-31
SOURce subsystem	14-32
SOURce[1]	14-32
Control source outputs on-off	14-32
[:IMMediate]	14-32
Select sourcing mode	14-32
MODE <name>	14-32
Select source function	14-33
FUNction[:SHAPE] <name>	14-33
Select source range	14-33
RANGe <n>	14-33
Set amplitudes	14-34
[:IMMediate][:AMPLitude] <n>	14-34
LOW <n>	14-34
Set voltage limit	14-35
PROtEction[:LEVel] <NRf>	14-35
Select source polarity	14-35
POLarity <name>	14-35
Set pulse times	14-36
DELay <n>	14-36
WIDTh <n>	14-36
TRANSition[:STATe] 	14-36
Configure sweeps	14-37
SPACing <name>	14-37
STARt <n>	14-37
STOP <n>	14-37
CENTer <n>	14-38
SPAN <n>	14-38
STEP <n>	14-39
POINts <n>	14-40
DIRection <name>	14-40
Configure list	14-41
CURRent <NRf list>	14-41
APPend <NRf list>	14-41
POINts?	14-42
WIDTh <NRf list>	14-42
APPend <NRf list>	14-42
POINts?	14-42
DELay <NRf list>	14-43
APPend <NRf list>	14-43
POINts?	14-43

Sweep and list program examples	14-44
Linear staircase sweep	14-44
List sweep	14-44
Logarithmic staircase sweep	14-45
SOURce2 and SOURce3	14-46
Set amplitudes	14-47
[:IMMediate][:AMPLitude] <n>	14-47
SOURce4	14-47
Setting digital output	14-47
[:LEVel] <NRf> <NDN>	14-47
Setting bit size	14-48
BSIZe <n>	14-48
STATus subsystem	14-49
Read event registers	14-49
[:EVENT]?	14-49
Program event enable registers	14-49
ENABle <NDN> or <NRf>	14-49
Read condition registers	14-50
CONDition?	14-50
Select default conditions	14-50
PRESet	14-50
Error queue	14-50
[:NEXT]?	14-50
CLEar	14-50
ENABle <list>	14-51
DISable <list>	14-51
SYSTEM subsystem	14-51
Default conditions	14-51
PRESet	14-51
POSetup	14-52
Error queue	14-52
[:NEXT]?	14-52
ALL?	14-52
COUNt?	14-53
CODE[:NEXT]?	14-53
CODE:ALL?	14-53
CLEar	14-53
Simulate key presses	14-53
KEY	14-53
Read version of SCPI standard	14-54
VERSion?	14-54
RS-232 interface	14-55
LOCal	14-55
REMote	14-55
RWLock	14-55

Reset timestamp	14-55
RESet	14-55
TRACe subsystem	14-56
Read sample buffer	14-56
DATA?	14-56
VALue? [<NRf>]	14-56
Configure sample buffer	14-57
POINts <n>	14-57
Trigger subsystem	14-57
Initiate source/measure cycle	14-57
INITiate	14-57
Abort source/measure cycle	14-58
ABORt	14-58
Program trigger model	14-58
COUNt <n>	14-58
SOURce <name>	14-58
TIMer <n>	14-59
ILINe <NRf>	14-60
OLINe <NRf>	14-60
OUTPut <name>	14-60

A Specifications

B Status and Error Messages

Introduction	B-2
Status and error messages	B-2
Eliminating common SCPI errors	B-7
-113, "Undefined header"	B-7
-410, "Query INTERRUPTED"	B-7
-420, "Query UNTERMINATED"	B-8

C Data Flow

Introduction	C-2
Buffers	C-2
SENS1, SENS2, and SENS3	C-3
INIT	C-3
FETCh?	C-3
READ? and MEASure?	C-4
CALCulate1:DATA?, CALCulate2:DATA?, CALCulate3:DATA?	C-4
CALCulate4:DATA?	C-4
TRACe:DATA? and TRACe:DATA:VALue?	C-4

D IEEE-488 Bus Overview

Introduction	D-2
Bus description	D-2
Bus lines	D-5
Data lines	D-5
Bus management lines	D-5
Handshake lines	D-5
Bus commands	D-7
Uniline commands	D-8
Universal multiline commands	D-8
Addressed multiline commands	D-9
Address commands	D-9
Unaddress commands	D-9
Common commands	D-10
SCPI commands	D-10
Command codes	D-10
Typical command sequences	D-12
IEEE command groups	D-13
Interface function codes	D-14

E IEEE-488 and SCPI Conformance Information

Introduction	E-2
--------------------	-----

F Measurement Considerations

Optimizing laser diode connections	F-2
Current pulse output circuit model	F-2
Cable inductance	F-3
Increasing cable length	F-5
Exposed loop area	F-6
Sense lead connections	F-8
Magnetic coupling	F-10
Increasing laser diode pulse measurement speed	F-11
Overview	F-11
Laser diode impedance matching	F-12
Model 2520 output circuit model	F-13
Transmission line model	F-14
Forward voltage measurement	F-15
Photodiode current measurement channels	F-16
Noise and source impedance	F-17
DUT resistance	F-17
Source capacitance	F-18
Generated currents	F-18
Offset currents	F-19
Dielectric absorption	F-19
Voltage burden	F-20
General measurement considerations	F-20

Ground loops	F-20
Light	F-21
Electrostatic interference	F-22
Magnetic fields	F-22
Electromagnetic Interference (EMI)	F-23

G GPIB 488.1 Protocol

Introduction	G-2
Selecting the 488.1 protocol	G-2
Protocol differences	G-3
Message exchange protocol (MEP)	G-3
Using SCPI-based programs	G-3
Bus hold-off	G-4
Trigger-on-talk	G-4
Message available	G-4
General operation notes	G-4

H Example Programs

Introduction	H-2
Hardware requirements	H-2
Software requirements	H-2
General program instructions	H-2
Laser diode test program	H-3
Linear staircase sweep program	H-4
List sweep program	H-5

I Continuous Pulse Mode

Continuous pulse mode	I-2
Pulse test advantage	I-2
Duty cycle	I-2
Configuring the 2520 to use Continuous Pulse Mode	I-3
Front panel	I-3
Remote configuration over GPIB/IEEE-488	I-4
Related modes	I-4

List of Illustrations

1 Getting Started

Figure 1-1	Mainframe front panel	1-6
Figure 1-2	Mainframe rear panel	1-8
Figure 1-3	Testhead front panel	1-9
Figure 1-4	Testhead rear panel	1-10

2 Connections

Figure 2-1	Testhead connections	2-4
Figure 2-2	Testhead signal connectors	2-5
Figure 2-3	DETECTOR connector terminals	2-6
Figure 2-4	Remote interlock connections	2-7
Figure 2-5	Laser diode test connections	2-8
Figure 2-6	Equivalent circuit of laser diode test connections	2-9

3 Basic Operation

Figure 3-1	Basic circuit configuration	3-5
Figure 3-2	Laser diode current source polarity	3-6
Figure 3-3	Laser diode measure polarity	3-7
Figure 3-4	Detector current measurement polarity	3-8

4 Laser Diode Testing

Figure 4-1	Circuit configuration for laser diode testing	4-3
------------	---	-----

5 Source-Measure Concepts

Figure 5-1	Delay-pulse cycle	5-2
Figure 5-2	Front panel fixed mode pulse parameters	5-4
Figure 5-3	Front panel staircase sweep mode pulse parameters	5-5
Figure 5-4	Front panel staircase sweep mode DC parameters	5-5
Figure 5-5	Remote fixed mode pulse parameters	5-6
Figure 5-6	Remote staircase sweep mode pulse parameters	5-7
Figure 5-7	Pulse characteristics	5-7
Figure 5-8	Sweep waveform types	5-9
Figure 5-9	Custom sweep waveform	5-9
Figure 5-10	Current source limit lines	5-10
Figure 5-11	Loading effects	5-11
Figure 5-12	Data flow-front panel	5-13

6 Range, Filter, and Math

Figure 6-1	Averaging filter during sweep	6-5
------------	-------------------------------------	-----

7	Sweep Operation	
Figure 7-1	Linear staircase sweep	7-2
Figure 7-2	Logarithmic staircase sweep	7-3
Figure 7-3	Custom pulse sweep	7-4
Figure 7-4	Sweep configuration menu tree	7-5
8	Triggering	
Figure 8-1	Trigger model (front panel operation)	8-2
Figure 8-2	Rear panel pinout	8-5
Figure 8-3	Trigger link input pulse specifications	8-6
Figure 8-4	Trigger link output pulse specifications	8-6
Figure 8-5	Configure trigger menu tree	8-8
Figure 8-6	Trigger model (remote operation)	8-10
9	Digital I/O Port, Interlocks, and Pulse Sync Output	
Figure 9-1	Digital I/O port	9-2
Figure 9-2	Sink operation	9-3
Figure 9-3	Source operation	9-4
Figure 9-4	Interlock operation	9-6
Figure 9-5	Pulse sync output waveform	9-8
Figure 9-6	Pulse sync out connections	9-9
10	Remote Operations	
Figure 10-1	IEEE-488 connector	10-4
Figure 10-2	IEEE-488 multi-unit test system connections	10-4
Figure 10-3	IEEE-488 and RS-232 connector location	10-5
Figure 10-4	RS-232 interface connector	10-18
11	Status Structure	
Figure 11-1	Model 2520 status register structure	11-3
Figure 11-2	16-bit status register	11-5
Figure 11-3	Status byte and service request (SRQ)	11-7
Figure 11-4	Standard event status	11-12
Figure 11-5	Operation event status	11-13
Figure 11-6	Measurement event status	11-15
Figure 11-7	Questionable event status	11-16
14	SCPI Command Reference	
Figure 14-1	ASCII data format	14-20
Figure 14-2	IEEE-754 single precision data format (32 data bits)	14-21

C	Data Flow	
Figure C-1	Data flow block diagram	C-2
D	IEEE-488 Bus Overview	
Figure D-1	IEEE-488 bus configuration	D-4
Figure D-2	IEEE-488 handshake sequence	D-6
Figure D-3	Command codes	D-11
F	Measurement Considerations	
Figure F-1	Model 2520 pulse output circuit model	F-2
Figure F-2	Rise time of 4A current pulse	F-4
Figure F-3	Rise time of 0.45A current pulse	F-5
Figure F-4	Effects of open loop area	F-6
Figure F-5	Ideal response of 2A pulse using 10 inch cables	F-7
Figure F-6	Response of 2A pulse with two square inch loop	F-7
Figure F-7	Sense lead connections	F-8
Figure F-8	Response of 2A pulse with sense leads 1/4 inch away from DUT	F-9
Figure F-9	Magnetic coupling	F-10
Figure F-10	Optical pulse propagation through differing indices of refraction	F-11
Figure F-11	Model 2520 output circuit model	F-13
Figure F-12	Minimal impedance mismatch	F-14
Figure F-13	Compromised shield provides laser diode access	F-14
Figure F-14	Voltage measurement circuit model	F-15
Figure F-15	Pulse source and forward voltage cable interconnections ...	F-15
Figure F-16	Model 2520 photo current measurement channels with dual bias supplies	F-16
Figure F-17	Voltage burden	F-20
Figure F-18	Eliminating ground loops	F-21
Figure F-19	Power line ground loops	F-21

List of Tables

1	Getting Started	
Table 1-1	Line fuse	1-12
Table 1-2	Basic display command	1-14
Table 1-3	Factory default settings	1-16
Table 1-4	Main menu	1-18
Table 1-5	COMM, SETUP, and DIG OUT menus	1-20
Table 1-6	PW, DELAY, and COMPL menus	1-21
Table 1-7	LASER and DETECTOR configuration menus	1-22
Table 1-8	TRIG and FILTER configuration menus	1-23
Table 1-9	SWEEP and MATH configuration menus	1-24
3	Basic Operation	
Table 3-1	Laser diode current source ranges	3-2
Table 3-2	Laser diode voltage measurement ranges	3-3
Table 3-3	Photodiode current measurement ranges	3-4
Table 3-4	Source and measure configuration commands	3-13
Table 3-5	Basic source and measure configuration example	3-14
4	Laser Diode Testing	
Table 4-1	Source and measure configuration menus	4-2
Table 4-2	Laser diode test commands	4-6
Table 4-3	Basic laser diode test command sequence	4-8
6	Range, Filter, and Math	
Table 6-1	Laser diode voltage measurement ranges	6-2
Table 6-2	Photodiode current measurement ranges	6-2
Table 6-3	Laser diode current source ranges	6-3
Table 6-4	Range commands	6-3
Table 6-5	Range programming example	6-4
Table 6-6	Filter commands	6-6
Table 6-7	Filter programming example	6-6
Table 6-8	Math configuration menu	6-8
Table 6-9	Math function commands	6-9
Table 6-10	Math function programming example	6-10
7	Sweep Operation	
Table 7-1	Logarithmic sweep points	7-4
Table 7-2	Linear and log staircase sweep commands	7-8
Table 7-3	Linear staircase sweep programming example	7-9
Table 7-4	Custom sweep commands	7-10
Table 7-5	Custom sweep programming example	7-11

8	Triggering	
Table 8-1	Remote trigger commands	8-14
Table 8-2	Remote triggering example	8-14
9	Digital I/O Port, Interlocks, and Pulse Sync Output	
Table 9-1	Digital output line settings	9-5
10	Remote Operations	
Table 10-1	General bus commands	10-6
Table 10-2	RS-232 connector pinout	10-19
Table 10-3	PC serial port pinout	10-19
11	Status Structure	
Table 11-1	Common and SCPI commands to reset registers and clear queues	11-4
Table 11-2	Data format commands for reading status registers	11-7
Table 11-3	Status byte and service request enable register commands	11-10
Table 11-4	Status byte programming example	11-10
Table 11-5	Condition register commands	11-17
Table 11-6	Event register commands	11-17
Table 11-7	Event enable registers commands	11-18
Table 11-8	Program and read register programming example	11-19
Table 11-9	Error queue commands	11-21
12	Common Commands	
Table 12-1	IEEE-488.2 common commands and queries	12-2
Table 12-2	*OPC programming example	12-4
Table 12-3	*SAV, *RCL programming example	12-5
Table 12-4	*TRG programming example	12-6
13	SCPI Signal-Oriented Measurement Commands	
Table 13-1	Signal-oriented measurement command summary	13-2
14	SCPI Command Reference	
Table 14-1	CALCulate command summary	14-3
Table 14-2	DISPlay command summary	14-5
Table 14-3	FORMat command summary	14-6
Table 14-4	OUTPut command summary	14-6
Table 14-5	SENSe command summary	14-7
Table 14-6	SOURce command summary	14-9
Table 14-7	STATus command summary	14-12

Table 14-8	SYSTem command summary	14-13
Table 14-9	TRACe command summary	14-13
Table 14-10	TRIGger command summary	14-14

B Status and Error Messages

Table B-1	Status and error messages	B-3
-----------	---------------------------------	-----

D IEEE-488 Bus Overview

Table D-1	IEEE-488 bus command summary	D-7
Table D-2	Hexadecimal and decimal command codes	D-10
Table D-3	Typical addressed multiline command sequence	D-12
Table D-4	Typical addressed common command sequence	D-12
Table D-5	IEEE command groups	D-13
Table D-6	Model 2520 interface function codes	D-14

E IEEE-488 and SCPI Conformance Information

Table E-1	IEEE-488 documentation requirements	E-3
Table E-2	Coupled commands	E-4

F Measurement Considerations

Table F-1	Minimum recommended source resistance values	F-17
-----------	--	------

1 Getting Started

- **General information** — Covers general information that includes warranty information, contact information, safety symbols and terms, inspection, and available options and accessories.
- **Product overview** — Summarizes the features of the Model 2520 Pulsed Laser Diode Test System.
- **Familiarization** — Summarizes the controls and connectors on the unit.
- **Power-up** — Covers line power connection, line voltage settings, fuse replacement, and the power-up sequence.
- **Display** — Provides information about the Model 2520 display.
- **Default settings** — Covers factory default setups and saving and recalling user setups.
- **Menus** — Covers the main and configuration menus as well as rules to navigate menus.

General information

Warranty information

Warranty information is located at the front of this manual. Should your Model 2520 require warranty service, contact the Keithley representative or authorized repair facility in your area for further information. When returning the instrument for repair, be sure to fill out and include the service form at the back of this manual to provide the repair facility with the necessary information.

Contact information

Worldwide phone numbers are listed at the front of this manual. If you have any questions, please contact your local Keithley representative or call one of our Application Engineers at 1-800-348-3735 (U.S. and Canada only). Additional information may be obtained at www.keithley.com.

Manual addenda

Any improvements or changes concerning the instrument or manual will be explained in an addendum included with the manual. Be sure to note these changes and incorporate them into the manual.

Specifications

Model 2520 specifications shown throughout the body of this manual and the detailed specifications listed in Appendix A were current at the time of printing, but they are subject to change without notice. For the most recent specifications, refer to the web site at www.keithley.com.

Safety symbols and terms

The following symbols and terms may be found on the instrument or used in this manual.

The  symbol on an instrument indicates that the user should refer to the operating instructions located in the manual.

The  symbol on the instrument shows that high voltage may be present on the terminal(s). Use standard safety precautions to avoid personal contact with these voltages.

The **WARNING** heading used in this manual explains dangers that might result in personal injury or death. Always read the associated information very carefully before performing the indicated procedure.

The **CAUTION** heading used in this manual explains hazards that could damage the instrument. Such damage may invalidate the warranty.

Inspection

The Model 2520 was carefully inspected electrically and mechanically before shipment. After unpacking all items from the shipping carton, check for any obvious signs of physical damage that may have occurred during transit. (There may be a protective film over the display lens, which can be removed.) Report any damage to the shipping agent immediately. Save the original packing carton for possible future shipment. The following items are included with every Model 2520 order:

- Model 2520 mainframe with line cord.
- Model 2520 testhead with two connecting cables.
- Two triax connecting cables for detector signal connections.
- Four unterminated 15 Ω BNC coaxial connecting cables for laser diode signal connections.
- Accessories as ordered.
- Certificate of calibration.
- User's Manual.
- Manual addenda, containing any improvements or changes to the instrument or manual.

If an additional user's manual is required, order the appropriate manual package (for example, 2520-900-00). The manual packages include a manual and any pertinent addenda.

Options and accessories

The following options and accessories are available from Keithley for use with the Model 2520.

Signal cables and adapters

CA-289-1A Cable — This 1m low-noise triax cable is terminated at one end with a 3-slot male triax connector and is unterminated on the other end.

CA-290-1A Cable — This 1m BNC cable is terminated at one end with a male BNC connector and is unterminated on the other end.

Model 7078-TRX Triax Cables — These low-noise triax cables are terminated at both ends with 3-slot male triax connectors. The Model 7078-TRX is available in 0.3m (1ft), 0.9m (3ft), 1.5m (5ft), and 3m (10ft) lengths.

Model 7078-TRX-BNC Adapter — This is a 3-slot male triax to female BNC adapter. This adapter lets you connect a BNC cable to the triax detector inputs of the Model 2520 testhead.

Model 237-TRX-TBC Connector — This is a 3-lug female triax bulkhead connector with cap for assembly of custom panels and interface connections.

Interface cables

Models 7007-1 and 7007-2 shielded GPIB cables — Connect the Model 2520 to the GPIB bus using shielded cables and connectors to reduce Electromagnetic Interference (EMI). The Model 7007-1 is 1m long; the Model 7007-2 is 2m long.

Model 7009-5 shielded RS-232 cable — Connect the Model 2520 to computer serial port using shielded cables and connectors to reduce EMI.

Models 8501-1 and 8501-2 trigger link cables — Connect the Model 2520 to other instruments with Trigger Link connectors (e.g., Model 7001 Switch System). The Model 8501-1 is 1m long; the Model 8501-2 is 2m long.

Model 8502 trigger link adapter — Lets you connect any of the six Trigger Link lines of the Model 2520 to instruments that use the standard BNC trigger connectors.

Model 8503 DIN to BNC trigger cable — Lets you connect Trigger Link lines one (Voltmeter Complete) and two (External Trigger) of the Model 2520 to instruments that use BNC trigger connectors. The Model 8503 is 1m long.

Rack mount kits

Model 4288-1 single fixed rack mount kit — Mounts a single Model 2520 in a standard 19-inch rack.

Model 4288-2 side-by-side rack mount kit — Mounts two instruments (Models 182, 428, 486, 487, 2000, 2001, 2002, 2010, 2015, 2016, 2400, 2410, 2420, 2430, 2500, 2510, 2520, 6430, 6517, 7001) side-by-side in a standard 19-inch rack.

Model 4288-3 side-by-side rack mount kit — Mounts a Model 2520 and a Model 199 side-by-side in a standard 19-inch rack.

Model 4288-4 side-by-side rack mount kit — Mounts a Model 2520 and a 5.25-inch instrument (Models 195A, 196, 220, 224, 230, 263, 595, 614, 617, 705, 740, 775, etc.) side-by-side in a standard 19-inch rack.

Model 4288-5 dual fixed rack mounting kit — Mounts a Model 2520 and another 3½-inch high instrument (Model 182, 428, 486, 487, 2000, 2010, 2400, 2410, 2420, 2430, or 7001) side-by-side in a standard 19-inch rack.

Product overview

The Model 2520 Pulsed Laser Diode Test System combines high-current laser diode pulse and voltage measurement capabilities, and two stable DC bias voltage sources with two low-noise ammeters for dual-channel photodiode measurements. The unit has 0.3% basic laser diode voltage measurement accuracy, and 0.3% basic photodiode current measurement accuracy. A separate, remote testhead allows versatility for signal connections.

The Model 2520 has the following source and measure capabilities:

- Source DC laser diode current from 10 μ A to 1A.
- Source laser diode current pulses from 10 μ A to 5.0A.
- Measure laser diode voltage from 0.33mV to 10.5V.
- Measure photodiode current from 0.7 μ A to 105mA on each of two channels.
- Source photodiode bias voltage on each of two channels from 0 to \pm 20V.

Some additional capabilities of the Model 2520 include:

- Sweep capabilities: linear and logarithmic staircase, and custom sweeps for the laser diode current source.
- Digital I/O port to control other instruments.
- Programming language and remote interfaces — The Model 2520 uses the SCPI programming language and two remote interface ports (IEEE-488/GPIB and RS-232C).
- Trigger-Link interface to Keithley Series 7000 switching hardware.
- Pulse sync out — Allows synchronizing external instruments with current pulse.
- Math functions — V/I, I/V, power, and MX + B functions.
- Reading and setup storage — Voltage and current readings and seven setups (five user defaults, factory default, *RST default) can be stored and recalled.
- Closed-cover calibration — The instrument can be calibrated either from the front panel or remote interface.

Mainframe front and rear panel familiarization

Front panel summary

The front panel of the Model 2520 mainframe is shown in [Figure 1-1](#).

Figure 1-1
Mainframe front panel

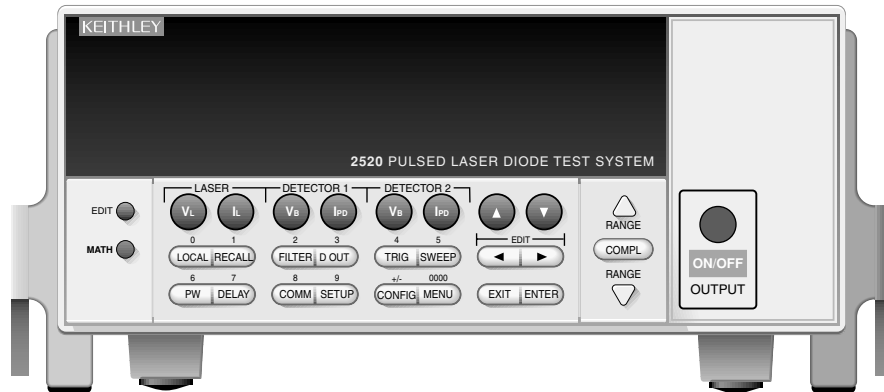

LASER keys:

- V_L Configure laser diode voltage measure.
- I_L Control laser diode current source.

DETECTOR 1 keys:

- V_B Control photodiode detector #1 bias voltage source.
- I_{PD} Configure photodiode detector #1 current measure.

DETECTOR 2 keys:

- V_B Control photodiode detector #2 bias voltage source.
- I_{PD} Configure photodiode detector #2 current measure.

EDIT keys:

- ▲ Increase value.
- ▼ Decrease value.
- ◀ Move cursor left.
- ▶ Move cursor right.

COMPL and RANGE keys:

- COMPL Set laser diode source voltage compliance (limit).
- RANGE ▲ Increase range.
- RANGE ▼ Decrease range.

Operation keys:

EDIT	Enter EDIT mode.
MATH	Enable math function.
LOCAL	Cancel remote operation.
RECALL	Display stored readings and timestamp.
FILTER	Control digital filter.
DIG OUT	Set Digital I/O port output value.
TRIG	Trigger a measurement from the front panel.
SWEEP	Start configured sweep.
PW	Set laser diode current source pulse width.
DELAY	Set laser diode current source pulse delay period.
COMM	Select remote interface, set GPIB and RS-232 operating parameters.
SETUP	Save/recall default or user instrument setup configurations.
CONFIG	Press CONFIG and then appropriate key to configure function or operation.
MENU	Access and configure Main Menu selections. When entering numeric data, use to clear reading to minimum absolute value.
EXIT	Cancels selection. Use to back out of menu structures.
ENTER	Accepts selection.

Annunciators:

EDIT	Instrument in edit mode.
ERR	Questionable reading, invalid cal step.
MATH	Math function enabled.
REM	Instrument in GPIB remote mode.
TALK	Instrument addressed to talk over GPIB.
LSTN	Instrument addressed to listen over GPIB.
SRQ	Service request over GPIB.
FILT	Digital filter enabled.
ARM	Source-measure operations being performed.
TRIG	External trigger source selected.

Output control:

ON/OFF OUTPUT Turns the source outputs on or off.

Handle:

Pull out and rotate to desired position.

Rear panel summary

The rear panel of the Model 2520 mainframe is shown in [Figure 1-2](#).

Figure 1-2
Mainframe rear panel

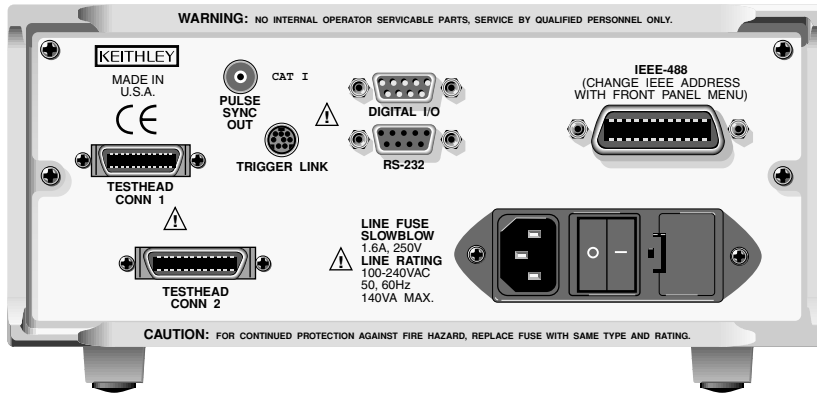

TESTHEAD connectors:

TESTHEAD CONN 1
TESTHEAD CONN 2

Connects to testhead MAINFRAME CONN1 connector.
Connects to testhead MAINFRAME CONN2 connector.

Pulse sync connector:

PULSE SYNC OUT

BNC connector provides TTL-compatible pulses synchronized with laser diode current source pulses.

Trigger link connector:

TRIGGER LINK

8-pin micro-DIN connector for sending and receiving trigger pulses. Use a trigger link cable or adapter, such as Models 8501-1, 8501-2, 8502, 8504.

Digital input/output port:

DIGITAL I/O

Male DB-9 connector for digital output lines, output enable line, and start-of-test signal.

RS-232 connector:

RS-232

Connector for RS-232 remote operation. Use a straight through (not null modem) DB-9 cable such as a Keithley Model 7009-5.

GPIB connector:

IEEE-488

Connector for GPIB remote operation. Use a shielded cable (Keithley Model 7007-1 or 7007-2).

Power module:

Contains the AC line receptacle, power on-off switch, and the power line fuse.

Testhead front and rear panel familiarization

Front panel summary

The front panel of the Model 2520 testhead is shown in [Figure 1-3](#).

Figure 1-3
Testhead front panel

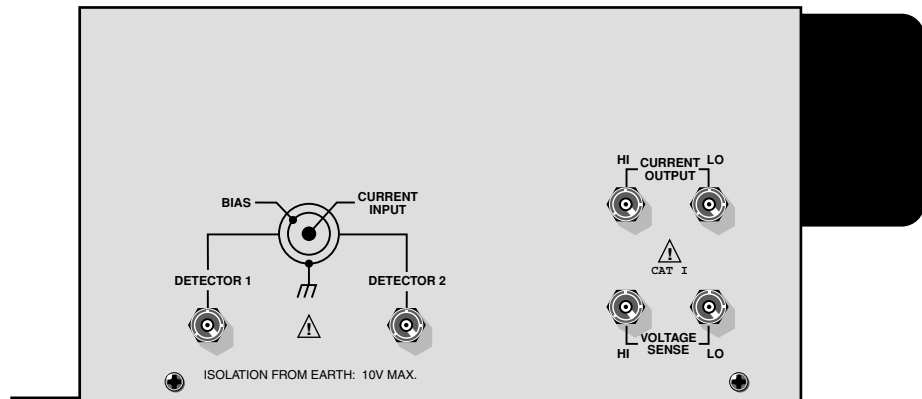

DETECTOR connectors:

DETECTOR 1 Use to bias and measure photodiode detector #1.
DETECTOR 2 Use to bias and measure photodiode detector #2.

Triax connector terminals: Center conductor – Current input
Inner shell – Voltage bias source output.
Outer shell – Chassis ground.

WARNING Isolation from earth is 10V maximum. Exceeding this value may result in a shock hazard.

Laser diode connectors:

CURRENT OUTPUT Current source HI and LO output terminals to laser diode.
VOLTAGE SENSE HI and LO sense terminals to measure laser diode voltage.

BNC connector terminals: Center conductor – Signal input or output.
Outer shell – Chassis ground.

Rear panel summary

The rear panel of the Model 2520 testhead is shown in [Figure 1-4](#).

Figure 1-4
Testhead rear panel

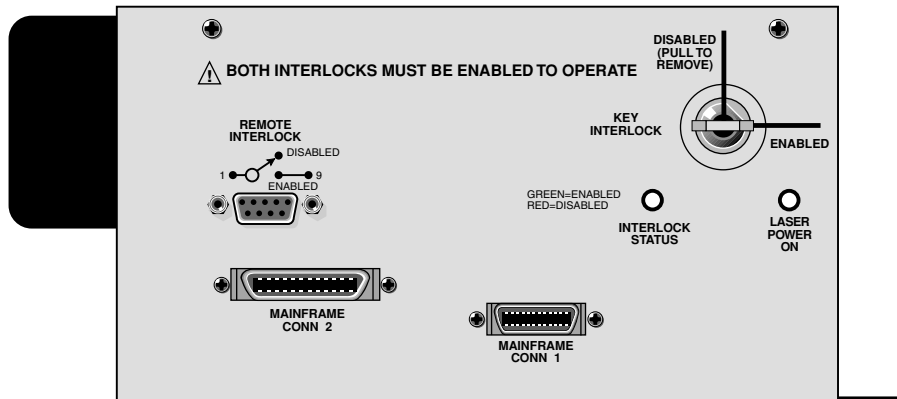

MAINFRAME connectors:

MAINFRAME CONN 1
MAINFRAME CONN 2

Connects to mainframe TESTHEAD CONN 1 connector.
Connects to mainframe TESTHEAD CONN 2 connector.

INTERLOCKS:

REMOTE INTERLOCK
KEY INTERLOCK

DB-9 connector for a remote interlock switch.
Key interlock switch (key must be inserted and rotated to ENABLED position to operate).

NOTE Both interlocks must be enabled to operate.

Indicator lights:

INTERLOCK STATUS
LASER POWER ON

Shows interlock status. Glows blue when disabled (source outputs cannot be turned on). Glows green when enabled (source outputs can be turned on).
Indicates when source outputs are turned on.

WARNING If at any time the indicators provided on the testhead, for **INTERLOCK STATUS** or **LASER POWER ON**, should fail to light or to properly indicate status, immediately contact a Keithley service representative for repair. Failure to do so may expose the user to hazards without proper warnings.

See “[Interlock status indicator test sequence](#),” [page 9-7](#), for instructions on verification of correct operation of the indicators.

Power-up

Line voltage

The Model 2520 operates from a line voltage in the range of 100V to 240V at a frequency of 50 or 60Hz. Line voltage selection is automatic.

CAUTION Operating the instrument on an incorrect line voltage may cause damage, possibly voiding the warranty.

Line power connection

Perform the following steps to connect the Model 2520 to line power and turn it on:

1. Before plugging in the power cord, make sure the rear panel power switch (located in the power module) is in the off (0) position.
2. Connect the female end of the supplied power cord to the AC receptacle on the rear panel.

WARNING The power cord supplied with the Model 2520 contains a separate ground for use with grounded outlets. When proper connections are made, instrument chassis is connected to power line ground through the ground wire in the power cord. Failure to use a grounded outlet may result in personal injury or death due to electric shock.

3. Turn on the instrument by pressing the rear panel power switch to the on (1) position.

Power-up sequence

On power-up, the Model 2520 performs self-tests on its EPROM and RAM and momentarily lights all segments and annunciators. If a failure is detected, the instrument momentarily displays an error message, and the ERR annunciator turns on. Error messages are listed in [Appendix B](#).

NOTE *If a problem develops while the instrument is under warranty, return it to Keithley Instruments, Inc., for repair.*

If the instrument passes the self-tests, the firmware revision levels are displayed. For example:

REV A01 A02 A03

where: A01 is the main processor ROM revision.

A02 is the DSP ROM revision.

A03 is the display board ROM revision.

The communication interface status is briefly displayed. If the IEEE-488 bus is the presently selected interface, the identification message will include the primary address. For example, if the primary address is 25 (factory default), the "IEEE Addr=25" message is displayed. If the RS-232 interface is selected, the "RS-232" message is displayed.

After the power-up sequence, the instrument goes to its normal display state with the output off (blue ON/OFF OUTPUT indicator and testhead POWER lights off).

System identification

To obtain the serial number and revision information, use the MENU/SERIAL # selection or the *IDN? query via remote.

Fuse replacement

A rear panel fuse protects the power line input of the Model 2520. If the line fuse needs to be replaced, perform the steps below:

WARNING Disconnect the line cord and all cables and test leads from the instrument before changing the line fuse.

1. The fuse is located in a holder in the power module adjacent to the AC receptacle (Figure 1-2.) At the right of the fuse holder is a small tab. At this location, use a small bladed screwdriver to release the fuse holder.
2. Slide the fuse holder out to gain access to the fuse carrier and fuse.
3. Remove the carrier with blown fuse, and replace the fuse with the correct type listed in Table 1-1.

CAUTION For continued protection against fire or instrument damage, replace the fuse only with the type and rating listed. If the instrument repeatedly blows fuses, locate and correct the cause of the problem before replacing the fuse.

4. Install the fuse carrier in the fuse holder, then insert the fuse holder in the power module.

Table 1-1

Line fuse

Line voltage	Fuse rating	Keithley part no.
100-240V	1.6A slow blow, 250V, 5 X 20mm	FU-106-1.6

Display

Display format

The Model 2520 display is used primarily to display measured readings and source values. The top line displays source values and the bottom line shows measured values.

Display example

The following example shows the unit displaying the laser diode source value on the top line, and the laser diode voltage, detector 1 current and detector 2 current from left to right on the bottom line:

```
Ipulse:100.00mA  
+1.0000 V +05.000mA +10.000mA
```

Display units

Measurement reading information can be displayed using either engineering units or scientific notation in either fixed- or floating-point format. Use the NUMBERS selection of the main MENU to select the display format, as discussed under “Menus,” page 1-17.

Engineering units example: 12.345mA

Scientific notation example: 1.23e -2A

Annunciators, which are located along the top of the reading/message display, indicate various states of operation, as covered previously in “Front panel summary,” page 1-6.

Status and error messages

Status and error messages are displayed momentarily. During Model 2520 operation and programming, you will encounter a number of front panel messages. Typical messages are either status or error in nature and are listed in [Appendix B](#).

Remote display programming

The display can also be controlled by various SCPI :DISPlay subsystem commands. [Table 1-2](#) summarizes the basic command to enable or disable the display. See [DISPlay subsystem](#) in [Section 14](#) for more information on using this and other display commands.

Table 1-2
Basic display command

Command	Description
:DISPlay:ENABLE <state>	Enable/disable display (state = ON or OFF).

Front panel display tests

Use the DISPLAY TESTS selection of the main MENU to test various aspects of the front panel. Test selections include:

- **KEYS** — Front panel keys are tested. Pressing a key displays a message that identifies that key. Pressing EXIT twice cancels this test.
- **DISPLAY PATTERNS** — Use this selection to turn on all display pixels and annunciators. Subsequent key presses cycle through tests that turn off annunciators and corner pixels of each digit, turn on the rows of the top-left display digit, and turn on all annunciators and pixels of each digit in a sequential manner. Press EXIT to cancel this test.
- **CHAR SET** — This test displays special characters. Press EXIT to cancel the test.

See “[Menus](#),” [page 1-17](#), for more menu information.

Default settings

By using appropriate menu selections, you can save and recall various instrument setups, define the power-on configuration, or restore factory defaults as outlined below.

Saving and restoring user setups

You can save and restore up to five of your own user setups using the following procedures.

Saving setups

1. Select the various instrument operating modes you wish to save.
2. Press the SETUP key.
3. From the SAVESETUP MENU, select SAVE, then press ENTER.
4. Select the setup position (0-4) to save, then press ENTER to complete the process.

Restoring setups

1. Press the SETUP key.
2. From the SAVESETUP MENU, select RESTORE, then press ENTER.
3. Select the setup position (0-4) to restore, then press ENTER to complete the process.

Power-on configuration

You can also define which of the stored setups (factory default or user) the instrument assumes as the power-on configuration as follows:

1. Press the SETUP key.
2. From the SAVESETUP MENU, select POWERON, then press ENTER.
3. From the SET POWER-ON DEFAULT menu, choose the power-on configuration: BENCH or GPIB (see below), or USER-SETUP-NUMBER.
4. If you chose to use a user setup as the power-on configuration, select the user setup number (0-4), then press ENTER.

Factory default settings

[Table 1-3](#) summarizes BENCH (front panel) and GPIB (remote) factory defaults for operating modes available from the front panel. (Some features are available only via remote; see [Section 14](#).) You can restore either of these default conditions from the front panel as follows:

1. Press the SETUP key.
2. From the SAVESETUP menu, select RESET, then press ENTER.
3. Select BENCH or GPIB defaults as desired, then press ENTER to complete the process.

Table 1-3
Factory default settings

Setting	BENCH default	GPIB default
Digital output		
Level	15	15
Filter:		
State	Disabled	Disabled
Average count	10	10
GPIB address	No effect	No effect
Math function		
V_L format	Resistance	Resistance
M factor (gain)	1	1
B factor (slope)	0	0
V_L units	X	X
I_{PD} units	W	W
State	Disabled	Disabled
Numbers	No effect	No effect
Output	Off	Off
Power-on default	No effect	No effect
Polarity		
Measure (V_L)	Positive	Positive
Source (I_L , V_B)	Positive	Positive
Range (measure)		
V_L	10V	10V
I_{PD}	100mA	100mA
RS-232	No effect	No effect
Sources		
I_L mode	Fixed	Fixed
I_L function	Pulse	Pulse
I_L range	500mA	500mA
I_L amplitude	0A	0A
I_L low amplitude	0A	0A
I_L pulse width	10 μ s	10 μ s
I_L pulse delay	0.1ms	0.1ms
I_L compliance	10V	10V
V_B amplitude	0V	0V

Table 1-3 (continued)
Factory default settings

Setting	BENCH default	GPIB default
Sweeps (I _L only)		
Type	None	None
Direction	Up	Up
Sweep points	1000	1000
Start	0A	0A
Stop	0A	0A
Step	0A	0A
Center	0A	0A
Span	0A	0A
Triggering		
Trigger input		
Event	Immediate	Immediate
Timer	0.1	0.1
Input line	1	1
Trigger output		
Event	Off	Off
Output line	2	2
Count	1	1
Init	Off	Off

Remote setups

You can also save and recall setups via remote using the following SCPI commands:

- Save and recall user setups using *SAV and *RCL (Section 13).
- Restore GPIB defaults using *RST (Section 13).
- Restore BENCH defaults using :SYSTem:PRESet (Section 14).
- Save the power-on configuration using :SYSTem:POSetup (Section 14).

Menus

The following paragraphs discuss the main menu, operation menus, configuration menus, and rules to navigate menus.

Main menu

Use the MENU key to access the Main Menu to select, configure, and/or perform various instrument operations. These include default setup conditions, communications (GPIB or RS-232), calibration, front panel tests, digital output states, auto zero, timestamp, and numeric display format.

The Main Menu structure is summarized in [Table 1-4](#). Use the “Rules to navigate menus” to check and/or change menu options.

Table 1-4
Main menu

Menu item ¹	Description
CAL ²	Calibrate Model 2520.
UNLOCK	Unlock calibration.
EXECUTE	Execute calibration.
VIEW-DATES	View last and next calibration dates.
SAVE	Save calibration constants.
CHANGE-PASSWORD	Change password.
TIMESTAMP	Reset timestamp (YES or NO).
TEST	Perform tests on Model 2520.
DISPLAY-TESTS ³	Test front panel keys and display digits.
KEYS	Test front panel keys.
DISPLAY-PATTERNS	Test display pixels and annunciators.
CHAR SET	Test special display characters.
SERIAL#	Display serial number, firmware revision, SCPI version.
NUMBERS	Select ENGR (engineering) units or SCIENTIFIC notation display format for measurement readings.

NOTES

1. Top level menu choices indicated in bold. Indentation identifies each lower submenu level.
2. Password is required to unlock calibration. (See Service Manual.) Only VIEW-DATES is accessible without password.
3. Press EXIT key to cancel test.

Rules to navigate menus

Many functions and operations are configured from the front panel menus. Use the following rules to navigate through these configuration menus:

- A menu item is selected by placing the cursor on it and pressing ENTER. Cursor position is denoted by the blinking menu item or option. The EDIT ◀ and ▶ keys control cursor position.
- A displayed arrow on the bottom line indicates there are one or more additional items (or messages) to select from. Use the appropriate cursor key to display them.

- A measurement or source range is changed by selecting the function by pressing any one of the LASER or DETECTOR function keys and using the RANGE ▲ or ▼ keys. (The unit must be in the edit mode to change the laser diode source range.) Note that when the next higher or lower range is selected, the reading increases or decreases by a decade.
- A parameter value is keyed in by placing the cursor on the digit to be changed and using one of the following methods:

NOTE You can clear a parameter value by pressing the 0000 (MENU) key.

- Use the EDIT ▲ or ▼ or RANGE ▲ or ▼ keys to increment or decrement the digit.
- Use the number keys (0 through 9) to key in the value at the selected digit.
- Use the ± key to change source value polarity, regardless of cursor position.
- Boolean selections (such as ON/OFF and HIGH/LOW) are toggled by placing the cursor on the selection and pressing an EDIT ▲ or ▼ or RANGE ▲ or ▼ key.
- A change is only executed when ENTER is pressed. Entering an invalid parameter generates an error, and the entry is ignored. However, entering an out-of-range value (too small or too large) selects the lower or upper limit, respectively.
- The EXIT key is used to back out of the menu structure. Any change that is not entered is cancelled when EXIT is pressed.

Main operation menus

The main operation menus described in [Table 1-5](#) are accessed by pressing one of these main operation keys:

- **COMM** — Selects GPIB or RS-232 interface, programs interface parameters.
- **SETUP** — Saves and recalls user and factory configurations.
- **DIG OUT** — Sets Digital I/O port binary output value.

Table 1-5
COMM, SETUP, and DIG OUT menus

Menu item ¹	Description
COMM	Select and set up GPIB or RS-232 interface.
COMMUNICATIONS SETUP ²	Communications setup menu.
GPIB	Select and set up GPIB interface.
ADDRESS	Set primary address (0-30). Default: 25.
GPIB PROTOCOL	Select protocol (see Appendix G).
488.1	Select 488.1 protocol.
SCPI	Select SCPI protocol.
RS-232	Select and set up RS-232 interface.
BAUD	Set baud rate (300, 600, 1200, 2400, 2800, 9600, 19200, 38400, 57600).
BITS	Set data bits (7 or 8).
PARITY	Set parity (NONE, ODD, or EVEN).
TERMINATOR	Select terminator (<CR>, <CR+LF>, <LF>, <LF+CR>).
FLOW-CTRL	Select flow control (NONE or XON-XOFF).
SETUP	Save and recall factory and user setups.
SAVESETUP MENU	Setup menu.
SAVE	Save user setups (0-4).
RESTORE	Restore user setups.
POWERON	Set power-on configuration.
BENCH	Use BENCH defaults as power-on.
GPIB	Use GPIB defaults as power-on.
USER-SETUP-NUMBER	User setup 0-4 as power-on default.
RESET	Restore factory default configuration.
BENCH	Restore bench (front panel) factory defaults.
GPIB	Restore GPIB (remote) factory defaults.
DIG OUT	
DIGITAL OUTPUT: 00000	Set digital output value (0-15; 0-65535 with 2499-DIGIO 16-bit option).

1. Main operating keys in bold.
2. Changing interface causes reset.

Table 1-6
PW, DELAY, and COMPL menus

Menu item	Description
PW PW: 0010.uS	Set laser diode current source (I_L) pulse width. Pulse width from 500ns to 5ms.*
DELAY PD: 00.10ms	Set laser diode current source pulse delay. Pulse delay from 20 μ s to 500ms.*
COMPL CMPL: 10.000 V	Set laser diode current source voltage compliance. Compliance (limit) from 3V to 10.5V.

* Settings affected by maximum duty cycle. See Section 5.

The main operation keys listed in Table 1-6 program these functions:

- **PW** — Sets laser diode current source (I_L) pulse width.
- **DELAY** — Sets laser diode current source pulse delay.
- **COMPL** — Sets laser diode current source voltage compliance (limit).

These operating modes are covered in more detail in later sections of this manual.

Configuration menus

There are a number of configuration menus that can be accessed by pressing the CONFIG key followed by the appropriate function or mode key. For example, you can configure the measurement functions by pressing CONFIG then LASER V_L , DETECTOR 1 I_{PD} , or DETECTOR 2 I_{PD} . Configuration menus, which are summarized in Table 1-7 through Table 1-9, are available for the following operating modes:

- Measure and source functions (LASER and DETECTOR keys): Table 1-7.
- TRIG and FILTER: Table 1-8.
- SWEEP and MATH: Table 1-9.

These various configuration menus are covered in detail in the pertinent sections of this manual.

Table 1-7
LASER and DETECTOR configuration menus

Configuration menu item	Description
CONFIG LASER V_L	Configure laser diode voltage measurement.
CHANNEL1 POLARITY	Select laser diode measurement polarity.
POSITIVE	Select positive measurement polarity.
NEGATIVE	Select negative polarity.
CONFIG DETECTOR 1 I_{PD}	Configure photodiode detector #1 current measurement.
CHANNEL2 POLARITY	Select photodiode detector #1 measurement polarity.
POSITIVE	Select positive measurement polarity.
NEGATIVE	Select negative polarity.
CONFIG DETECTOR 2 I_{PD}	Configure photodiode detector #2 measurement.
CHANNEL3 POLARITY	Select photodiode #2 measurement polarity.
POSITIVE	Select positive measurement polarity.
NEGATIVE	Select negative polarity.
CONFIG LASER I_L	Configure laser diode voltage current source.
CONFIGURE I SOURCE	
POLARITY	Select source polarity.
POSITIVE	Select positive polarity.
NEGATIVE	Select negative polarity.
SHAPE	Select current source output mode.
DC	DC current output.
PULSE	Pulse current output.
LOW	Set pulse low amplitude (0-15mA, 500mA range; 0 to 150mA, 5A range).

Table 1-8
TRIG and FILTER configuration menus

Configuration menu item	Description
CONFIG TRIG	Configure triggering.
CONFIGURE TRIGGER	
COUNT	Specify trigger count.
FINITE	Programmable count.
INFINITE	Never ending count.
INIT	Enable/disable INIT continuous.
ON	Turn on continuous.
OFF	Turn off continuous.
HALT	Return unit to idle.
TRIGGER-IN	Configure input triggers.
EVENT	Select trigger input detection event.
IMMEDIATE	Immediate event detection.
GPIB	GPIB GET or *TRG.
TIMER	After timer interval elapses (enter interval).
MANUAL	Front panel TRIG key.
TLINK	Enter trigger link line (1-6) and state.
↓STEST	When Digital I/O SOT is pulsed low.
↑STEST	When Digital I/O SOT line is pulsed high.
↑↓STEST	When Digital I/O SOT line is pulsed either high or low.
TIMER	Set trigger timer interval.
TRIGGER-OUT	Configure output triggers.
LINE	Select trigger link output line (1-6).
EVENTS	Enable/disable output events.
TRIG-LAYER-DONE	Enable (ON) or disable (OFF) on exiting trigger layer.
CONFIG FILTER	
AVG: 10 RDGS (1-100)	Program number of averaged filter readings (1-100).

Table 1-9
SWEEP and MATH configuration menus

Configuration menu item	Description
CONFIG SWEEP	Configure sweeps for laser diode current source (I_L).
CONFIGURE SWEEPS	
TYPE	Select sweep type.
NONE	Disable sweeps.
STAIR	Linear staircase sweep, program START, STOP and STEP.
LOG	Log staircase sweep, program START, STOP, NO OF POINTS.
SWEEP-COUNT	Set sweep count.
FINITE	Program sweep count value.
INFINITE	Never-ending sweep.
CONFIG MATH	Configure math functions.
CONFIGURE MATH	
CHANNEL1	Program V_L (laser diode voltage) math function.
I/V	Select conductance function (I_L/V_L).
V/I	Select resistance function (V_L/I_L).
MX+B_UNIT	Select $MX + B$ function, program M, B, and units.
P ζ	Select power function ($V_L \times I_L$).
CHANNEL2	Program I_{PD} (detector #1) $MX + B$, M, B, and units.
CHANNEL3	Program I_{PD} (detector #2) $MX + B$, M, B, and units.

2

Connections

- **Connection precautions** — Summarizes precautions that should be observed when making test connections to the Model 2520.
- **Testhead preparation** — Discusses testhead mounting and how to connect the Model 2520 mainframe to the testhead.
- **Signal connectors** — Shows the locations of the signal jacks used for laser diode and photodiode source and measurement and details the terminal configuration of the triax connectors on the testhead.
- **Interlock connections** — Details connections to the remote interlock circuit, which is used to inhibit the outputs with external switching.
- **Laser diode test connections** — Provides detailed diagrams for connecting the Model 2520 signal connectors to the laser diode and photodiodes in a laser diode test system.

Connection precautions

WARNING While the Model 2520 does not incorporate a laser, it is designed to operate (power) laser diode devices. Read all safety precautions listed at the beginning of this manual. The following safety practices must be used to protect operators and other users of this product from potential exposure to laser radiation:

- Operators must be protected from radiation and electrical hazards at all times.
- The installer must comply with all applicable laws and regulations on laser safety. This requirement includes warning signs and operator training.
- The interlock is required for safe operation. The test fixtures must ensure that the interlock circuit is disabled (source outputs inhibited) so that an operator is not exposed to any radiation. The test fixture interlock must not be defeated.
- The testhead key control must be used to prevent operation unless authorized by the responsible body. This requirement must be part of the facilities administrative controls for laser safety.
- When servicing the test system, any required personnel protection equipment (e.g. laser safety goggles) must be provided by the customer's responsible body.
- The customer's laser safety officer (LSO) must review and approve all installations before being put into operation. Any safety concerns must be immediately reported to the customer's LSO.
- If at any time, the indicators provided on the testhead for INTERLOCK STATUS or LASER POWER ON should fail to light or properly indicate status, immediately contact a Keithley service representative for repair. Failure to do so may expose the user to hazards without proper warnings. See [“Interlock status indicator test sequence,” page 9-7](#), for details on testing the indicator lights.
- Maximum isolation from earth ground is 10V. Exceeding this value may result in a shock hazard.
- When making connections, do not leave any exposed connections. Be sure that all external circuits are properly insulated.

Testhead preparation

Testhead mounting

The Model 2520 has a mounting ear with two holes (2.5 inches on-center) that allow the unit to be mounted in a location convenient to the test fixture. When mounting the testhead, be sure to allow sufficient clearance around the heat sink for proper cooling.

CAUTION To prevent damaging heat build-up and thus, ensure specified performance, adhere to the following precautions:

- Keep the heat sink free of dust, dirt, and contaminants, since its ability to dissipate heat could become impaired.
- Do not position any devices adjacent to the testhead that force air (heated or not) into or onto its surfaces or cooling vents. This additional airflow could compromise accurate performance.
- Make sure there is adequate airflow around the bottom and sides to ensure proper cooling. Adequate airflow enables air temperatures within approximately one inch of the testhead surfaces to remain within specified limits under all operating conditions.

Testhead connections

CAUTION Turn off the mainframe power before connecting or disconnecting the testhead to the mainframe.

Figure 2-1 shows connections between the Model 2520 mainframe and the testhead. Using the supplied cables, make connections as follows:

- Connect the mainframe TESTHEAD CONN 1 connector to the testhead MAINFRAME CONN 1 connector.
- Connect the mainframe TESTHEAD CONN 2 connector to the testhead MAINFRAME CONN 2 connector.

Figure 2-1
Testhead connections

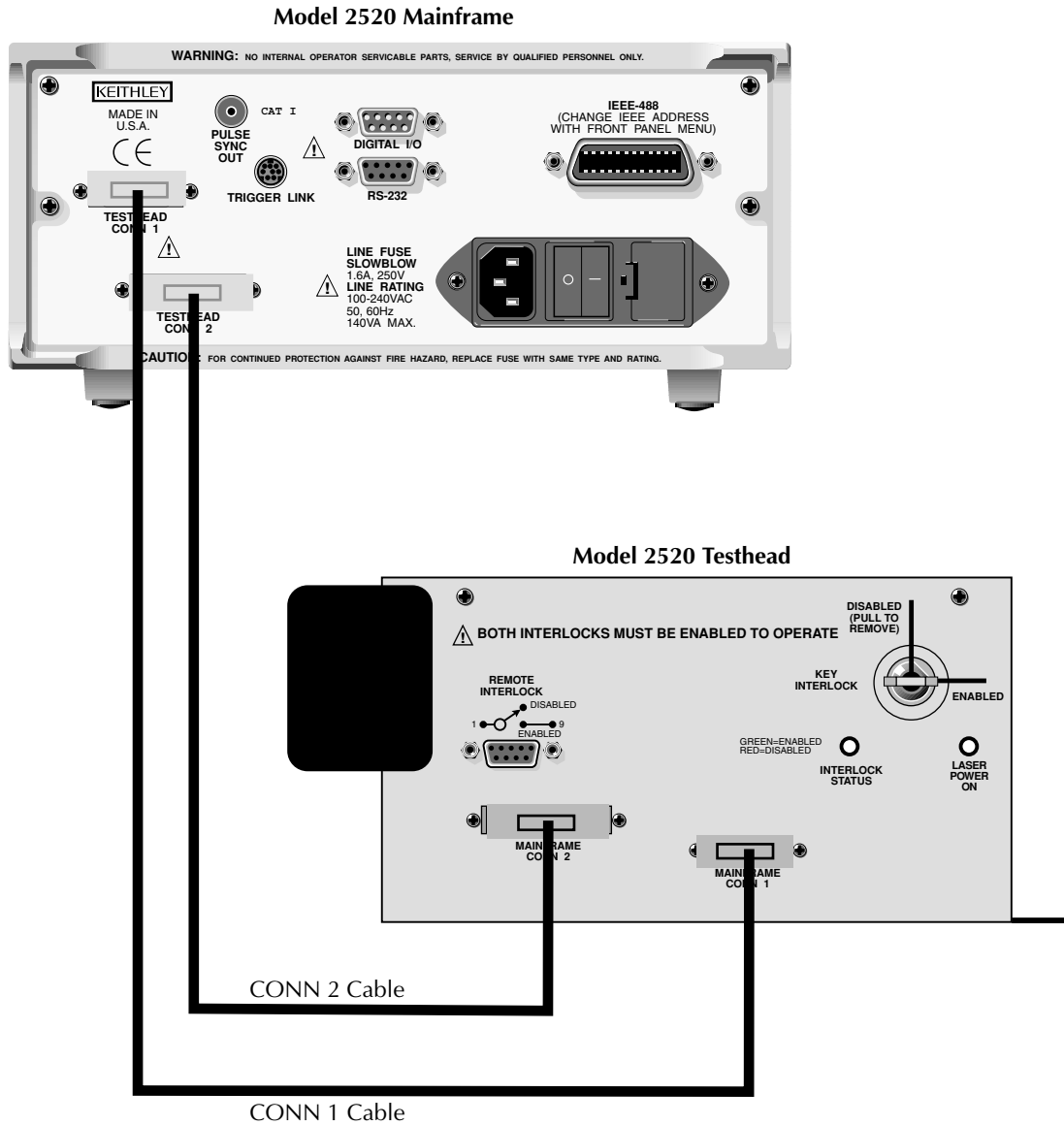

Signal connectors

Signal connectors

Figure 2-2 shows the location of the signal connectors on the front panel of the testhead. These connectors are further described below.

Figure 2-2
Testhead signal connectors

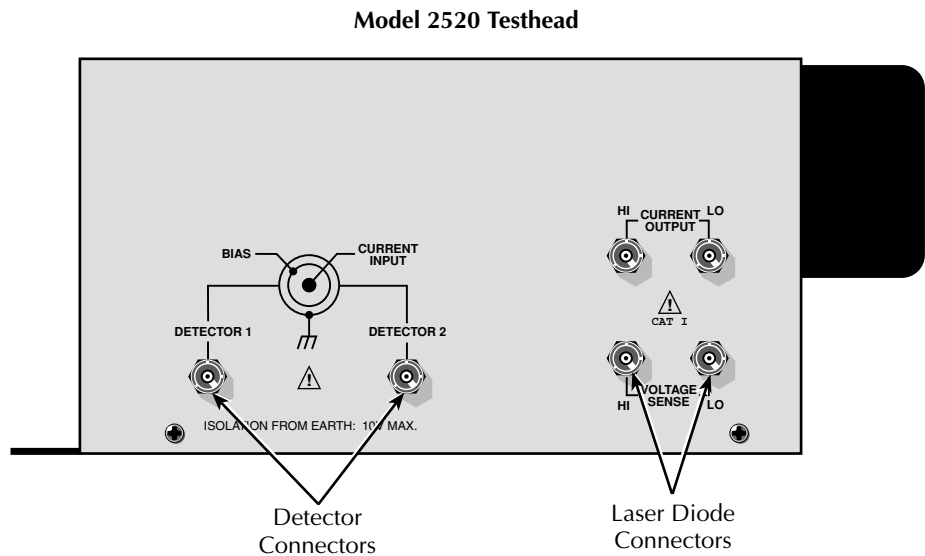

Triax DETECTOR connectors

The electrical configuration of each triax DETECTOR connector is shown in [Figure 2-3](#). Connector terminals are designated as follows:

- Center conductor of the connector (and triax cable): current input. This terminal connects to one terminal of the photodiode being used as a detector.
- Inner ring of the connector and inner cable shield: voltage bias source. This terminal connects to the other photodiode terminal.
- Outer ring of connector (shell) and outer cable shield: chassis ground.

Figure 2-3
DETECTOR connector terminals

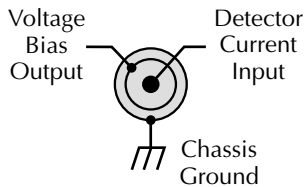

CURRENT OUTPUT and VOLTAGE SENSE connectors

CURRENT OUTPUT and VOLTAGE SENSE are BNC jacks used for making connections to the laser diode under test. CURRENT OUTPUT HI and LO provide current source connections to the DUT, while VOLTAGE SENSE HI and LO sense the voltage across the DUT. Note that the center pin of each connector is signal, while the outer shell is chassis ground.

Interlock connections

The Model 2520 has two interlock circuits, a remote interlock and a key interlock.

NOTE *Both interlocks must be enabled to operate. Otherwise the source outputs will not turn on.*

Remote interlock connections

A remote interlock switch should be wired to pins 1 and 9 of the REMOTE INTERLOCK connector, as shown in [Figure 2-4](#). (Connections can also be made between pins 1 and 5). The switch must be configured to close contacts (enabled) to operate. See [Section 9](#) for more information.

Figure 2-4
Remote interlock connections

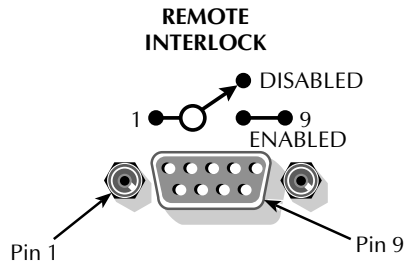

Key interlock

The key must be inserted into KEY INTERLOCK and rotated to the ENABLED position to operate the unit. Rotate the key to the DISABLED position and remove the key to inhibit the source outputs.

Laser diode test connections

Connecting cables

For optimum performance, use only the supplied connecting cables or the equivalent. Be sure the connector insulating boots are in place and properly seated to assure ESD (electro-static discharge) protection.

Typical connections

Figure 2-5 shows typical connections to the laser diode, the back detector photodiode, and the front detector photodiode in a laser diode test setup (interlock connections are not shown; see Figure 2-4). Connections are as follows:

- The center conductors of the CURRENT OUTPUT and VOLTAGE SENSE HI and LO terminals connect to the laser diode under test. Current is applied to the laser diode through the CURRENT OUTPUT HI and LO terminals, and voltage across the DUT is measured through the VOLTAGE SENSE HI and LO terminals.
- DETECTOR 1 connects to the forward detector photodiode. The CURRENT INPUT (center conductor) is connected to one photodiode terminal while the BIAS terminal (inner shield) is connected to the other photodiode terminal.
- DETECTOR 2 connects to the back detector photodiode. The CURRENT INPUT (center conductor) is connected to one photodiode terminal while the BIAS terminal (inner shield) is connected to the other photodiode terminal.

NOTE The BNC cable shields should be connected as shown if possible. If one terminal of the laser diode is to be earth grounded, it must be the anode.

Figure 2-5
Laser diode test connections

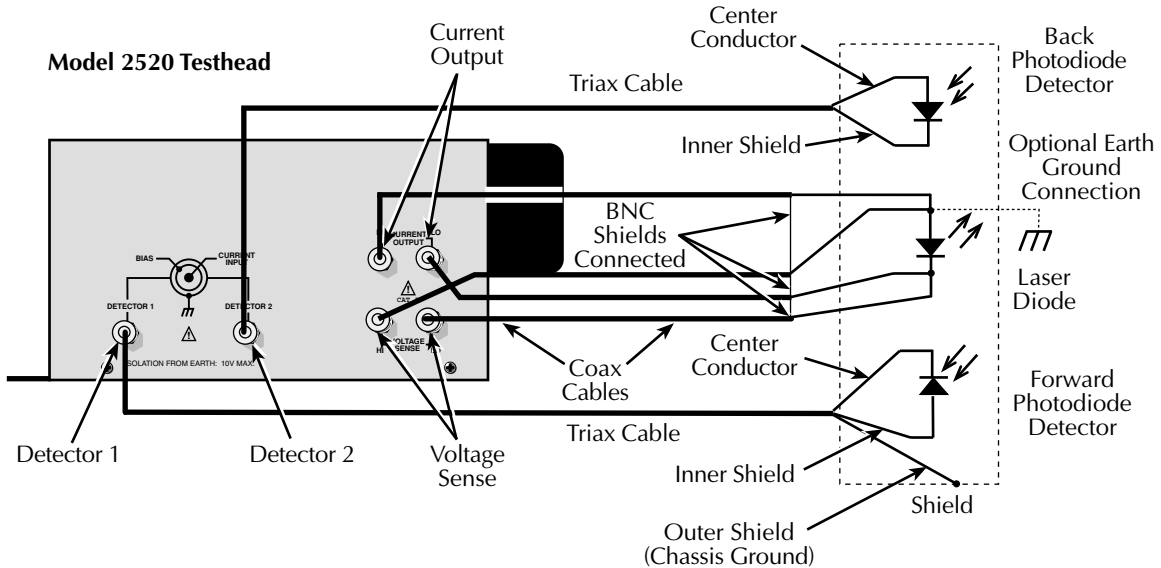

Equivalent circuit

Figure 2-6 shows an equivalent circuit for the connection scheme shown in Figure 2-5. The circuit includes the current source and voltmeter to excite and measure the laser diode, two ammeters to make photodiode current measurements, and two voltage sources to bias the photodiodes.

Polarity considerations

All measurements are unipolar. If a particular measurement polarity is set up incorrectly, the Model 2520 will display the “OVERFLOW” message. For detector (I_{PD}) measurements, current flowing into the ammeter (center conductor of the DETECTOR triax connector) is negative, while current flowing out is positive. For laser diode voltage (V_L) measurements, the measurement is positive when the HI terminal is at a higher polarity than the LO terminal, and negative when the HI terminal is at a lower polarity than the LO terminal.

Figure 2-6
Equivalent circuit of laser diode test connections

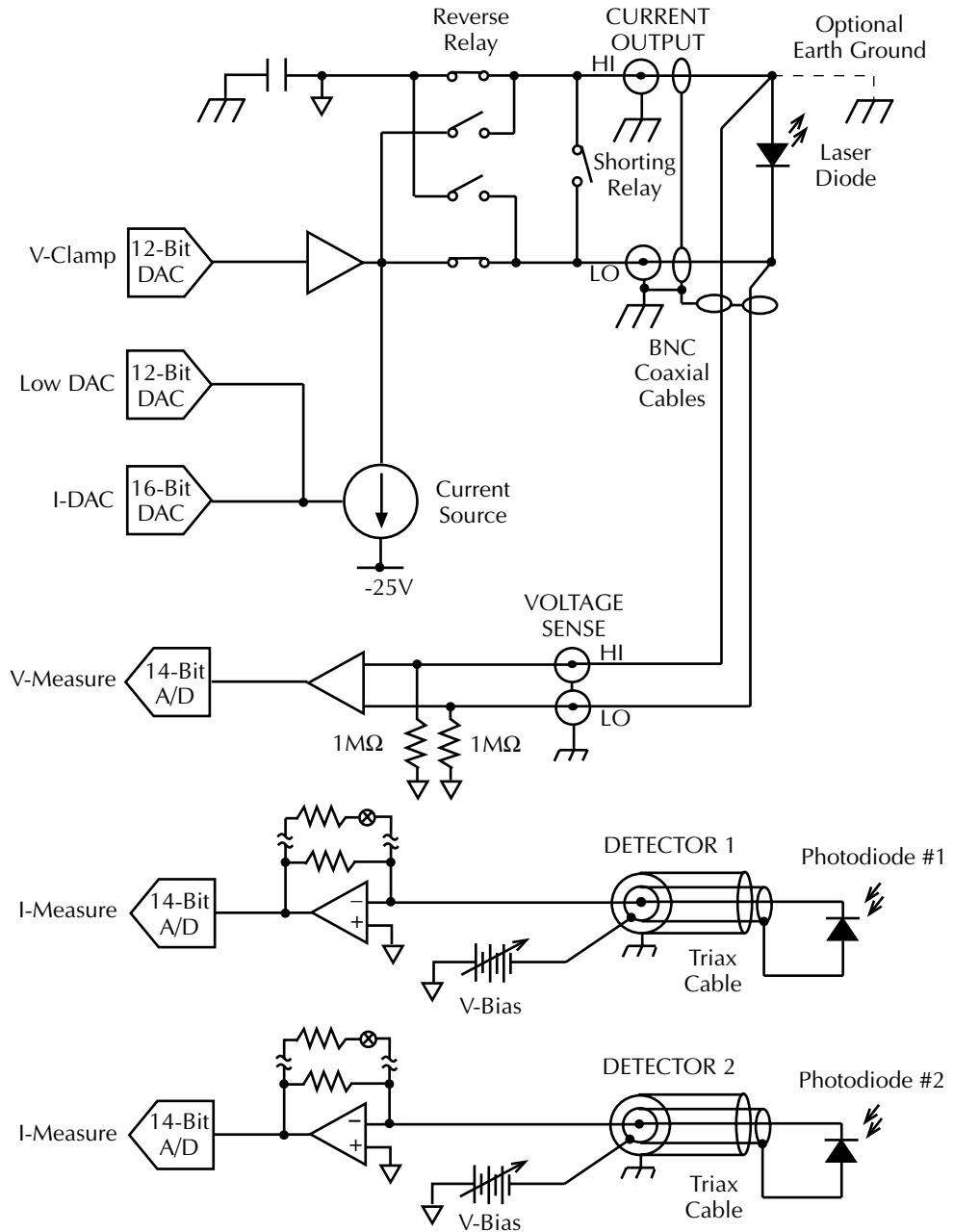

Connection considerations

When making connections to the laser diode, observe the following considerations to avoid pulse degradation due to distributed inductance and other effects:

- Use only the supplied 15 Ω coaxial cables.
- Keep cable lengths to a minimum.
- Connect the four cable shields together at the DUT.
- Carry cable shields as close to the DUT as possible. Minimize the length of exposed (unshielded) signal lines.
- Dress the VOLTAGE SENSE cables as far away from the CURRENT OUTPUT cables to avoid magnetic coupling. Twist the SENSE cables together to further reduce magnetic coupling.
- Connect the VOLTAGE SENSE leads as close to the body of the DUT as possible.

NOTE See *Appendix F, "Measurement Considerations,"* for information on these and other possible measurement problems and how to avoid them.

3

Basic Operation

- **Operation overview** — Discusses current and voltage source and measure capabilities, ranges, compliance, and fundamental measurement and voltage bias circuit configuration.
- **Configuring sources** — Covers setting up the laser diode current source and photodiode voltage bias source values.
- **Configuring measurements** — Covers setting up both laser diode voltage and photodiode current measurements.

Operation overview

Laser diode source and measure capabilities

The Model 2520 has the following laser diode current source and voltage measurement capabilities:

- **Source Current** — The Model 2520 can source DC current to the laser diode from 8 μ A to 1A (DC or pulse mode), 5.0A (pulse mode only). In the pulse mode, pulse on time (pulse width) is adjustable from 500ns to 5ms in 100ns increments, and pulse off time (pulse delay) is adjustable from 20 μ s to 500ms in 10 μ s increments.

NOTE Pulse width and delay settings are affected by maximum duty cycle. See [Section 5](#).

- **Measure Voltage** — The Model 2520 can measure laser diode DC voltage from 0.33mV to 10.5V on two ranges: 5V and 10V.

WARNING It is the responsibility of the customer to operate instruments in a safe manner. Follow all applicable safety regulations for installing, configuring and using the Model 2520. The Model 2520, as installed, should be approved by the appropriate safety personnel, such as the responsible Laser Safety Officer or equivalent.

Suggested starting points for workplace regulations and standards: ANSIZ136.1, IEC 825, OSHA 29 CFR 1910.

In short, always be aware of workplace hazards, strive to minimize them, and work safely.

Laser diode source and measure ranges

[Table 3-1](#) summarizes laser diode current source ranges, resolutions, and maximum output values while [Table 3-2](#) lists voltage measurement ranges, resolutions, and maximum voltages. See [Section 6](#) for more details on ranging.

Table 3-1
Laser diode current source ranges

Current range	Maximum resolution	Maximum output
500mA	10 μ A	500mA
5A	100 μ A	5.0A*

* Pulse mode only, Maximum DC current is 1A.

Table 3-2
Laser diode voltage measurement ranges

Voltage range	Resolution	Maximum reading
5V	0.33mV	±5.25V
10V	0.66mV	±10.5V

Laser diode source compliance

The laser diode current source has a maximum DC output level of 1A @ 9.9V, for a maximum power of 9.9W. Maximum pulse output level is 5A @ 9V, for a maximum pulse power of 45W. If the load resistance is high enough so that the unit exceeds the programmed voltage limit, the unit is considered to be in compliance, and the source display field will blink. See [Section 5](#), “[Source-Measure Concepts](#)” for more information. The unit can be programmed to generate an SRQ under compliance conditions over the GPIB ([Section 11](#)).

The compliance voltage is sensed at the pulser circuit board, so any I/R drops in the cables or connections is not sensed, and no corrections are made for these resistances.

Photodiode source and measure capabilities

Each Model 2520 photodiode channel has the following current measurement and voltage bias capabilities:

- **Measure Current** — Each Model 2520 photodiode channel can measure DC currents from 0.7 μ A to 105mA. Each channel has four current ranges: 10mA, 20mA, 50mA, and 100mA.
- **Source Voltage** — Each Model 2520 photodiode bias source can output DC voltage from 0 to \pm 20V.

Photodiode source and measure ranges

Table 3-3 summarizes photodiode current measurement ranges, resolutions, and maximum readings. Note that each photodiode voltage bias source has a single 20V range. See Section 6 for more details on ranging.

Table 3-3
Photodiode current measurement ranges

Current range	Maximum resolution	Maximum reading
10mA	0.7 μ A	\pm 10.5mA
20mA	1.4 μ A	\pm 21mA
50mA	3.4 μ A	\pm 52.5mA
100mA	6.8 μ A	\pm 105mA

Basic circuit configuration

The fundamental circuit configuration for Model 2520 is shown in Figure 3-1. (See Figure 2-6 for a more detailed equivalent circuit.) In addition to the laser diode current source and voltage measurement circuits, the unit has two separate photodiode channels, each of which includes a feedback ammeter and a $0 \pm 20V$ voltage bias source.

Figure 3-1
Basic circuit configuration

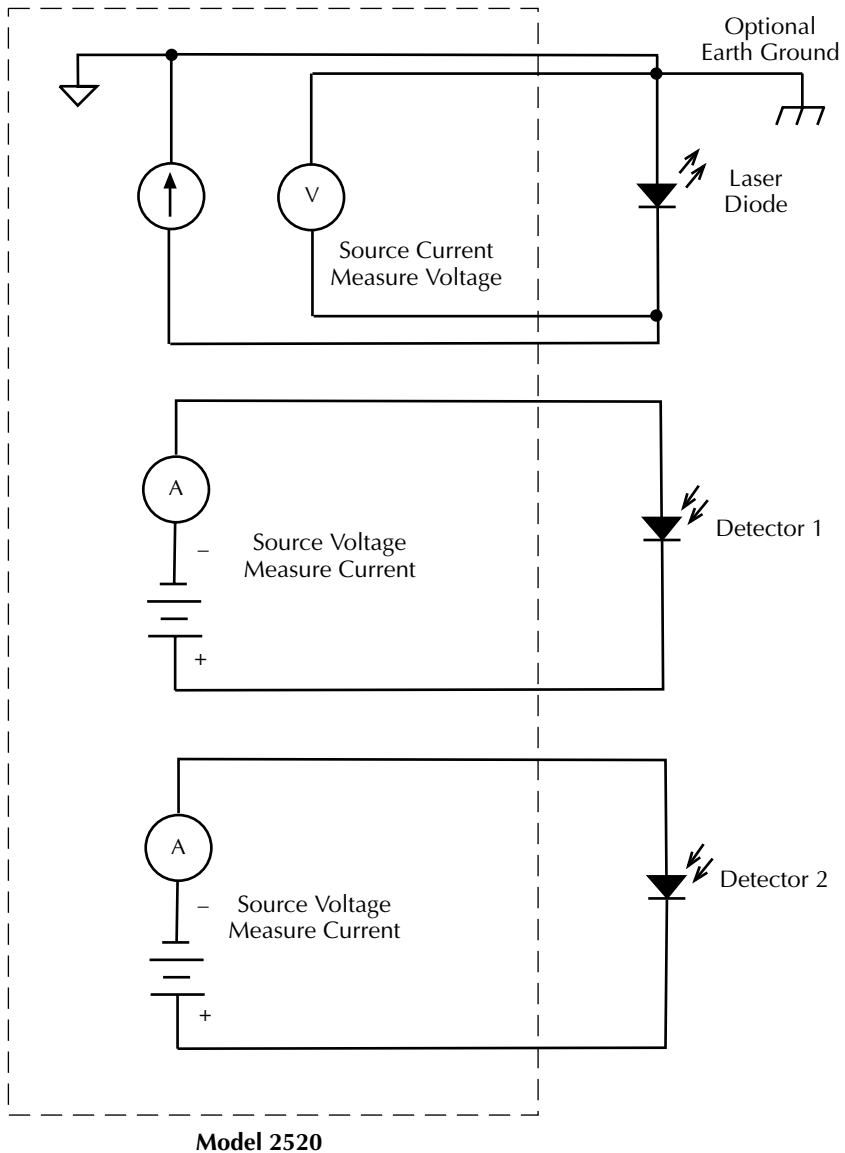

Polarity

Polarity for the laser diode current source, both detector current measurements, and laser diode voltage measurement can be controlled by using the POLARITY selections in the corresponding configuration menus (see “Configuring sources,” page 3-9, and “Configuring measurements,” page 3-12, for procedures to set the polarity).

Laser diode current source polarity

Figure 3-2 shows a comparison of positive and negative current source polarity. With the positive polarity shown in A, current across the DUT develops a voltage such that the positive DUT terminal is connected to CURRENT OUTPUT HI, and the negative DUT terminal is connected to CURRENT OUTPUT LO. With the negative polarity shown in B, the negative DUT terminal is connected to CURRENT OUTPUT HI, and the positive terminal is connected to CURRENT OUTPUT LO.

Figure 3-2

Laser diode current source polarity

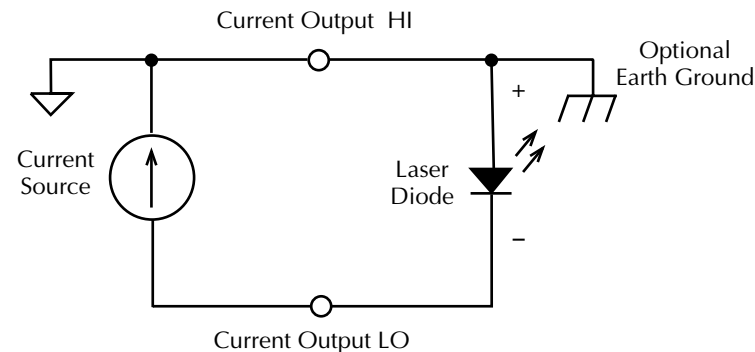

A. Positive Polarity

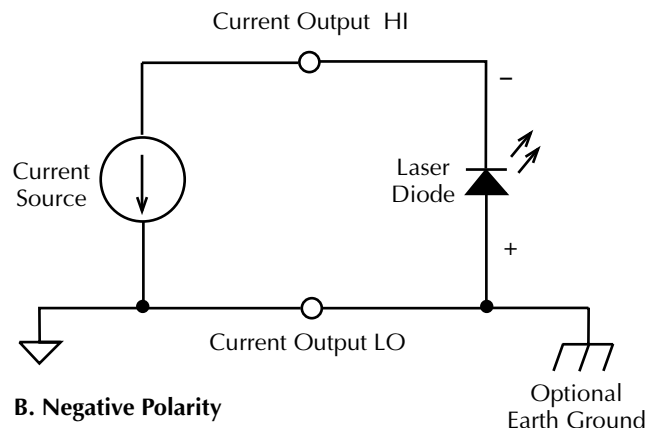

B. Negative Polarity

Laser diode voltage measurement polarity

Figure 3-3 shows the basic configuration for laser diode voltage measurement polarity. Figure 3-3A shows correct connections for POSITIVE polarity. In this case, the laser diode positive terminal is connected to the VOLTAGE SENSE HI terminal, while the negative laser diode terminal is connected to the VOLTAGE SENSE LO terminal. Figure 3-3B shows correct connections for NEGATIVE polarity. In this case, the laser diode positive terminal is connected to the VOLTAGE SENSE LO terminal, while the negative laser diode terminal is connected to the VOLTAGE SENSE HI terminal.

NOTE *Laser diode voltage measurements are essentially unipolar, and the polarity setting must agree with the polarity connections of the laser diode. If the polarity is set incorrectly, an overflow reading will be displayed.*

In order to reduce common-mode errors in voltage measurements, connect the HI voltage measurement terminal to the same terminal as current source HI, and connect the LO voltage measurement terminal to current source LO (Figure 2-6). In this situation, set the voltage measurement polarity to the same setting (POSITIVE or NEGATIVE) as the current source polarity.

Figure 3-3

Laser diode measure polarity

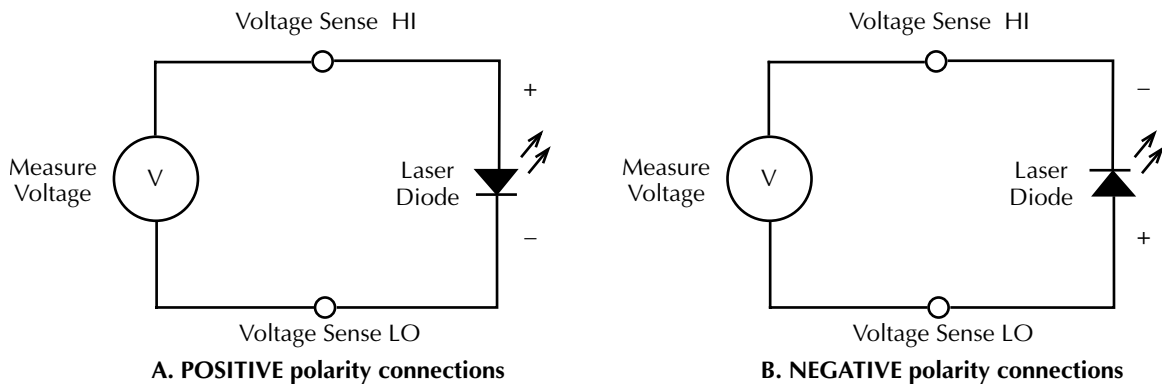

Note: Incorrect polarity setting will result in overflow voltage reading.

Detector measurement polarity

Figure 3-4 shows the basic configuration for detector current measurement polarity. With connections shown in Figure 3-4A, current will flow into the current input (center conductor of the triax connector). Under these conditions, the measured current is negative, and the polarity setting must also be NEGATIVE. Conversely, if the current is flowing out of the triax connector (Figure 3-4B), the measured current is positive, and the polarity setting must be POSITIVE.

NOTE *Detector current measurements are essentially unipolar, and the polarity setting must agree with the polarity connections of the photodiode. If the polarity is set incorrectly, an overflow reading will be displayed.*

Voltage bias polarity

The voltage bias outputs are bipolar, and there is no separate polarity setting. Simply set the voltage bias value to the desired value in the range of $\pm 20\text{V}$. This bias voltage value will be output on the inner shield of the detector triax jack relative to the center conductor terminal. For example, if you set the bias voltage to $+10\text{V}$, the inner shield will be at a potential of $+10\text{V}$ relative to the center conductor of the triax jack.

Figure 3-4

Detector current measurement polarity

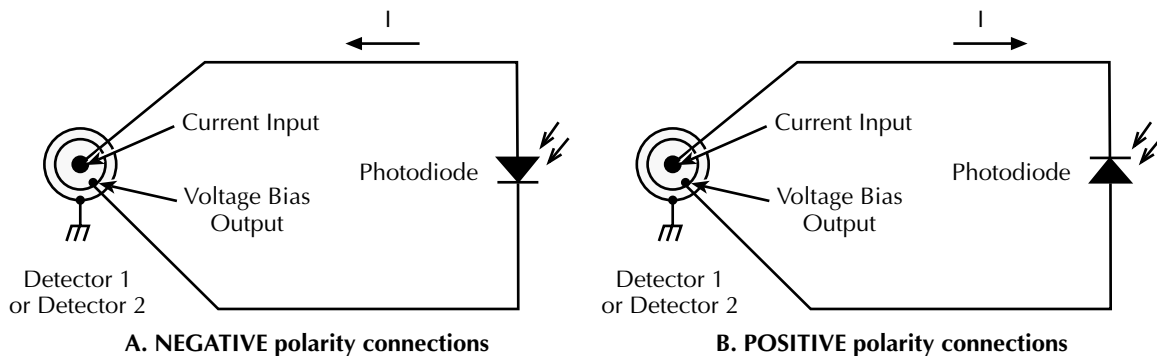

Note: Incorrect polarity setting will result in overflow current reading

Configuring sources

Follow the general procedures below to set source and compliance values for the laser diode current source as well as bias voltage values for the two photodiode sources.

Editing source values

Use the following keys to edit source values:

- **LASER IL, DETECTOR 1 VB, and DETECTOR 2 VB** — selects the laser diode, photodiode #1, or photodiode #2 source for editing.
- **EDIT** — edits the last selected source. A blinking cursor will appear in the field to be edited, and the EDIT annunciator will turn on while in the edit mode. If no key is pressed within a few seconds, the edit mode will be cancelled automatically.
- **COMPL** — allows editing of the laser diode current source voltage compliance.
- **EDIT ◀ and ▶** — places the display cursor on the display digit to be changed.
- **EDIT ▲ or ▼** — increments or decrements the source value. Note that pressing either of these keys will automatically enable the source edit mode.
- **RANGE ▲ or ▼** — selects the laser diode source range (500mA or 5A) while in edit mode.
- **ENTER** — Completes source editing without waiting for time-out period.
- **Numeric keys (0-9)** — allow you to directly enter source values.
- **EXIT** — exits the edit mode without waiting for the time-out period.

Configuring laser diode source

The basic procedure for setting up laser diode current source values for both DC and pulse modes is outlined below.

DC mode

1. Press CONFIG then LASER I_L to access the source configuration menu.
2. Choose POLARITY, then press ENTER.
3. Select POSITIVE or NEGATIVE as desired, then press ENTER. (See [Figure 3-2](#) for a comparison of positive and negative source polarity.)
4. Select SHAPE, then press ENTER.
5. Choose DC, then press ENTER.
6. Press EXIT to return to normal display.
7. Press the LASER I_L key, then the EDIT key so the blinking cursor is in the I_L source display field.
8. While in the edit mode, use the RANGE \blacktriangle and \blacktriangledown keys to select the desired source range (500mA or 5A). Use the lowest range possible for best accuracy.
9. To simply increment or decrement the displayed source value, use the EDIT \blacktriangleleft and \blacktriangleright keys to place the blinking cursor on the digit to be changed, then increment or decrement the value with the EDIT \blacktriangle and \blacktriangledown keys. Note that the source value will be updated immediately; you need not press ENTER to complete the process, but you can press ENTER to exit the edit mode immediately.
10. To enter the source value directly, simply key in the desired value with the numeric keys while the cursor is blinking. Again, the source value will be updated immediately.
11. Press the COMPL key, then set the voltage compliance (limit) to the desired value. Press ENTER to complete your selection and return to normal display.

Pulse mode

1. Press CONFIG then LASER I_L to access the source configuration menu.
2. Choose POLARITY, then press ENTER.
3. Select POSITIVE or NEGATIVE as desired, then press ENTER (Figure 3-2).
4. Select SHAPE, then press ENTER.
5. Choose PULSE, then press ENTER.
6. Select LOW, then press ENTER.
7. Set the pulse low amplitude to the desired value, then press ENTER.
8. Press EXIT to return to normal display.
9. Press the PW key, then set the pulse width to the desired value.
10. Press the DELAY key, then set the pulse delay as required.
11. Press the LASER I_L key, then press EDIT to enter the edit mode.
12. While in the edit mode, use the RANGE \blacktriangle and \blacktriangledown keys to select the desired source range (500mA or 5A).
13. Use the EDIT \blacktriangle and \blacktriangledown or numeric keys to set the source amplitude to the desired level. For the pulse mode, this value will be the high pulse level.
14. Press the COMPL key, then set the voltage compliance (limit) to the desired value. Press ENTER to complete your selection and return to normal display.

Setting photodiode detector source values

The basic procedure for editing photodiode detector source values is outlined below.

1. Press the DETECTOR 1 V_B or DETECTOR V_B key, then the EDIT key so the blinking cursor is in the source display field to be edited.
2. To simply increment or decrement the displayed source value, use the EDIT \blacktriangleleft and \blacktriangleright and \blacktriangle and \blacktriangledown keys, or use the numeric keys to enter the value directly. Again, the source value will be updated immediately; you need not press ENTER to complete the process.
3. Repeat steps 1 and 2 for the other photodiode source.

Configuring measurements

Follow the general procedures below to set the range and polarity for both laser diode and photodiode measurements.

NOTE *The pulse width setting affects not only the source, but the measurement as well. The larger the pulse width, the more A/D samples that will be averaged to generate a measurement, which decreases noise, but increases test time. In the DC mode, the pulse width setting effectively becomes the aperture (sample time) for the entire measurement.*

Configuring laser diode measurements

1. Press CONFIG then LASER V_L to access the laser diode measurement configuration menu.
2. Choose POLARITY, then press ENTER.
3. Select POSITIVE or NEGATIVE as desired, then press ENTER (Figure 3-3).
4. Press the LASER V_L key.
5. Use the RANGE ▲ and ▼ keys to select the desired measurement range (5V or 10V). Use the lowest range possible for best accuracy.

Configuring photodiode measurements

1. Press CONFIG then either DETECTOR 1 I_{PD} or DETECTOR 2 I_{PD} to access the photodiode measurement configuration menu.
2. Choose POLARITY, then press ENTER.
3. Select POSITIVE or NEGATIVE as desired, then press ENTER (Figure 3-4).
4. Press the DETECTOR 1 I_{PD} or DETECTOR 2 I_{PD} key.
5. Use the RANGE ▲ and ▼ keys to select the desired measurement range (10mA, 20mA, 50mA, or 100mA). Use the lowest range possible for best accuracy.
6. Repeat steps 1 through 6 for the other photodiode detector channel.

Remote source and measure configuration

Source and measure configuration can also be performed via remote by sending appropriate commands. The following paragraphs summarize these commands and give a simple programming example.

Source and measure configuration commands

Table 3-4 summarizes commands used for source and measure configuration. See Section 14 for more information on using these and other commands.

Table 3-4

Source and measure configuration commands

Command	Description
Configure measurements: :SENSe[1]:VOLTage:RANGe <range> :SENSe[1]:VOLTage:POLarity <polarity> :SENSe2:CURRent:RANGe <range> :SENSe2:CURRent:POLarity <polarity> :SENSe3:CURRent:RANGe <range> :SENSe3:CURRent:POLarity <polarity> Configure sources: :SOURce[1]:CURRent:MODE FIXEd :SOURce[1]:CURRent:RANGe <range> :SOURce[1]:CURRent <current> :SOURce[1]:CURRent:POLarity <polarity> :SOURce[1]:VOLTage:PROTection <limit> :SOURce[1]:FUNctIon <function> :SOURce[1]:PULSe:DELay <delay> :SOURce[1]:PULSe:WIDTh <width> :SOURce[1]:CURRent:LOW <low_current> :SOURce2:VOLTage <voltage> :SOURce3:VOLTage <voltage>	Set laser diode voltage measure range (5 or 10). Set laser diode measure polarity (POSitive or NEGative). Set detector #1 measure range (0.01, 0.02, 0.05, 0.1). Set detector #1 measure polarity. Set detector #2 measure range (0.01, 0.02, 0.05, 0.1). Set detector #2 measure polarity. Select fixed (not sweep) laser diode current source mode. Select laser diode source range (0.5 or 5). Set laser diode source current (0 to +5.0). ¹ Set laser diode source polarity (POSitive or NEGative). Set laser source voltage compliance limit (1 to 10). Select laser diode current source function (DC or PULSe). Set laser diode source pulse delay (20e-6 to 0.5). ² Set laser diode source pulse width (500e-9 to 5e-3). ² Set low pulse amplitude for pulse mode (0 to 15e-3, 500mA range; 0 to 150e-3, 5A range). Set detector #1 source voltage (0 to ±20). Set detector #2 source voltage (0 to ±20).

¹ 5.0A maximum pulse mode only. 1A maximum in DC mode.

² Settings affected by maximum duty cycle. See Section 5.

Programming example

Table 3-5 summarizes the command sequence for basic source and measure configuration.

NOTE See Section 4 for complete test procedures.

These commands set up the Model 2520 as follows:

- Laser diode voltage measurement range and polarity: 10V, positive.
- Photodiode measurement polarity: negative (both detectors).
- Laser diode source: 0.5A range, +0.5A amplitude, 5V voltage limit, positive polarity.
- Laser diode source mode: pulse, delay = 100 μ sec, width = 10 μ sec, low I = 10mA.
- Detector #1 source: +20V amplitude.
- Detector #2 source: +10V amplitude.

Table 3-5

Basic source and measure configuration example

Commands	Comments
:SENS1:VOLT:RANG 10	Laser diode measure range = 10V.
:SENS1:VOLT:POL POS	Laser diode positive measure polarity.
:SENS2:CURR:POL NEG	Detector #1 negative measure polarity.
:SENS3:CURR:POL NEG	Detector #2 negative measure polarity.
:SOUR1:CURR:RANG 0.5	0.5A laser diode source range.
:SOUR1:CURR 0.5	Laser diode source output = 0.5A.
:SOUR1:VOLT:PROT 5	5V laser diode source voltage limit.
:SOUR1:CURR:POL POS	Laser diode source positive polarity.
:SOUR1:FUNC PULS	Laser diode source pulse mode.
:SOUR1:PULS:DEL 100e-6	100 μ sec pulse delay.
:SOUR1:PULS:WIDT 10e-6	10 μ sec pulse width.
:SOUR1:CURR:LOW 10e-3	10mA low current pulse.
:SOUR2:VOLT 20	Detector #1 bias source level = 20V.
:SOUR3:VOLT 10	Detector #2 bias source level = 10V.

4

Laser Diode Testing

- **Source and measure configuration menus** — Briefly summarizes the menus for configuring the laser diode source as well as all three measurement functions.
- **Front panel laser diode testing** — Provides a detailed procedure for performing laser diode tests from the front panel.
- **Remote laser diode testing** — Summarizes remote commands for testing laser diodes via remote and also gives a programming example.

Source and measure configuration menus

Table 4-1 summarizes the measurement and source configuration menus used in this section. See Section 3 for configuration procedures.

WARNING It is the responsibility of the customer to operate instruments in a safe manner. Follow all applicable safety regulations for installing, configuring and using the Model 2520. The Model 2520, as installed, should be approved by the appropriate safety personnel, such as the responsible Laser Safety Officer or equivalent.

Table 4-1
Source and measure configuration menus

Configuration menu item	Description
CONFIG LASER V_L CHANNEL1 POLARITY POSITIVE NEGATIVE	Configure laser diode voltage measurement. Select laser diode measurement polarity. Select positive measurement polarity. Select negative polarity.
CONFIG DETECTOR 1 I_{PD} CHANNEL2 POLARITY POSITIVE NEGATIVE	Configure detector #1 current measurement. Select detector #1 measurement polarity. Select positive measurement polarity. Select negative polarity.
CONFIG DETECTOR 2 I_{PD} CHANNEL3 POLARITY POSITIVE NEGATIVE	Configure detector #2 measurement. Select detector #2 measurement polarity. Select positive measurement polarity. Select negative polarity.
CONFIG LASER I_L CONFIGURE I SOURCE POLARITY POSITIVE NEGATIVE SHAPE DC PULSE LOW	Configure laser diode voltage current source. Select source polarity. Select positive polarity. Select negative polarity. Select current source output mode. DC current output. Pulse current output. Set pulse low amplitude (0-15mA, 500mA range; 0 to 150mA, 5A range).

Front panel laser diode testing

Test circuit configuration

The basic circuit configuration for the laser diode test procedures in this section is shown in Figure 4-1. (See Figure 2-5 for a more detailed drawing.) Note that connections for laser diode as well as both photodiode detectors are included, but the required interlock connections are not shown. See Section 2, "Connections," for detailed signal connection information as well as interlock connections.

Figure 4-1
Circuit configuration for laser diode testing

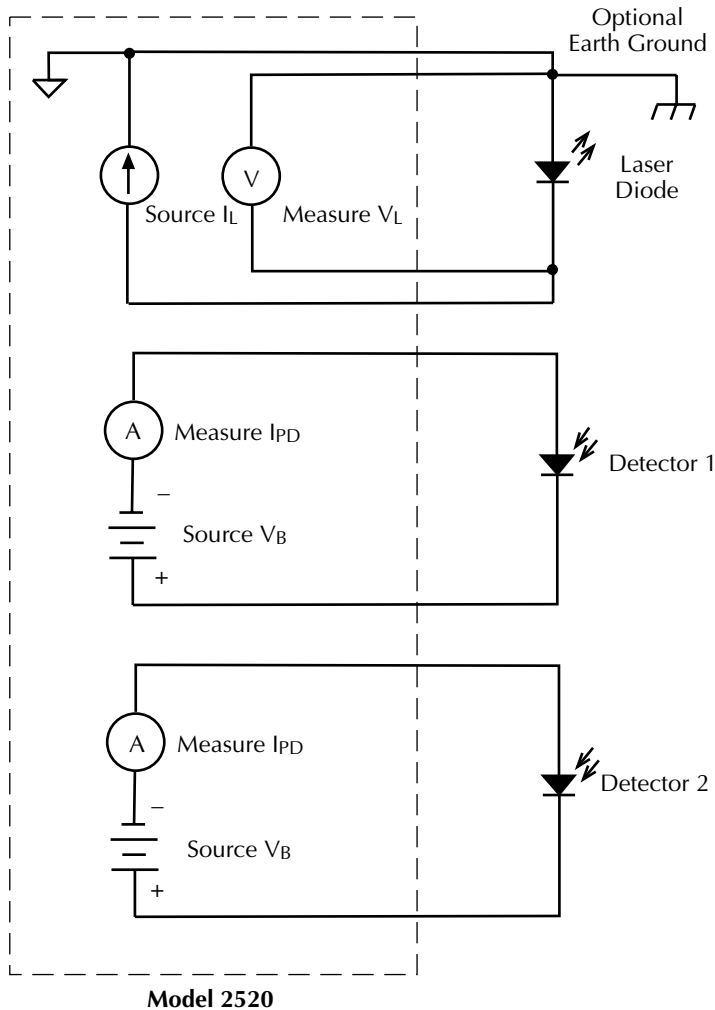

Front panel test procedure

Step 1: Configure laser diode measurement function.

Configure the laser diode measurement function as follows:

1. Press CONFIG then LASER V_L .
2. Choose POSITIVE or NEGATIVE polarity as desired, then press ENTER.
3. Press LASER V_L , then use the RANGE ▲ and ▼ keys to choose the measurement range (5V or 10V) based on the expected voltage measurement. Use the lowest range possible for best accuracy.

Step 2: Configure photodiode detector measurement functions.

Configure the photodiode detector measurement functions as follows:

1. Press CONFIG then DETECTOR 1 I_{PD} .
2. Choose POSITIVE or NEGATIVE polarity as desired, then press ENTER.
3. Press DETECTOR 1 I_{PD} , then use the RANGE ▲ and ▼ keys to choose the measurement range (10mA, 20mA, 50mA, or 100mA) based on the expected current measurement. Use the lowest range possible for best accuracy.
4. Repeat steps 1 through 3 for DETECTOR 2.

Step 3: Configure laser diode current source.

Set up the laser diode source as follows:

1. Press CONFIG then LASER I_L to access the source configuration menu.
2. Choose POLARITY, then set the polarity to POSITIVE or NEGATIVE as desired.
3. Choose SHAPE, then select the DC or PULSE mode as desired.
4. If you chose PULSE, select LOW, then set the pulse low amplitude.
5. Press EXIT to return to normal display.
6. If you chose the PULSE mode in step 3, program the pulse delay and width using the DELAY and PW keys.
7. Press the COMPL key then program the voltage compliance (limit) as desired.
8. Press LASER I_L , then press the EDIT key to enter the edit mode.
9. Use the RANGE ▲ and ▼ keys to select the source range (500mA or 5A) that will best accommodate the value you want to set.
10. Using either the EDIT or numeric entry keys, enter the desired current source value.

Step 4: Configure photodiode detector voltage bias sources.

Set up the photodiode detector voltage bias sources as follows:

1. Press DETECTOR 1 V_B to edit the photodiode #1 source.
2. Using either the EDIT or numeric entry keys, enter the desired source value (0 to $\pm 20V$).

3. Press DETECTOR 2 V_B to select the photodiode #2 source.
4. Again, using either the EDIT or numeric entry keys, set the bias source value to the desired value.

Step 5: Configure math functions.

Set up your math functions as desired. For example, these steps will set up the unit for laser diode power and detector 1 $MX + B$ math:

1. Press CONFIG then MATH.
2. Select CHANNEL1, then press ENTER.
3. Select P_f for power, then press ENTER.
4. Press CONFIG then MATH.
5. Choose CHANNEL2, then press ENTER.
6. At the subsequent prompts, set the $MX + B$ parameters (M, B, and units) to the desired values.

Step 6: Turn source outputs on and trigger readings.

Turn all three source outputs on by pressing the ON/OFF OUTPUT key. The blue OUTPUT indicator on the mainframe and the testhead POWER ON indicators will turn on to indicate the outputs are on. Press the TRIG key to trigger readings.

NOTE Interlocks must be enabled before outputs can be turned on. See Section 2.

Step 7: Observe readings on the display.

Observe the measurement readings on the display. For this example, the unit will display laser diode power, detector 1 $MX + B$ math, and detector 2 current on the lower line.

Step 8: Turn source outputs off.

When finished making measurements, turn all three source outputs off by pressing the ON/OFF OUTPUT key. The blue OUTPUT and POWER ON indicator lights will turn off.

Remote laser diode testing

Laser diode test procedures can also be performed via remote by sending appropriate commands in the right sequence. The following paragraphs summarize the commands and give a simple programming example.

Laser diode test commands

Table 4-2 summarizes commands used for basic laser diode testing, including those for the two photodiode detectors. See Section 14 for more information on using these and other commands for laser diode testing.

Table 4-2
Laser diode test commands

Command	Description
:CALCulate[1]:FORMat <format>	Define laser diode math format (MXB[1], CONDuctance[1], POWER[1], or RESistance[1]). ¹
:CALCulate[1]:DATA?	Request laser diode math reading.
:CALCulate[1]:STATe <state>	Enable/disable laser diode math (ON or OFF).
:CALCulate[1]:KMATH:MBFactor 	Set laser diode MX + B, B (offset) parameter.
:CALCulate[1]:KMATH:MMFactor <M>	Set laser diode MX + B, M (slope) parameter.
:CALCulate[1]:KMATH:MUNits "<units>"	Define laser diode MX + B units (1-character ASCII string).
:CALCulate2:DATA?	Request detector #1 math reading.
:CALCulate2:STATe <state>	Enable/disable detector #1 math (ON or OFF).
:CALCulate2:KMATH:MBFactor 	Set detector #1 MX + B, B (offset) parameter.
:CALCulate2:KMATH:MMFactor <M>	Set detector #1 MX + B, M (slope) parameter.
:CALCulate2:KMATH:MUNits "<units>"	Define detector 1 MX + B units (1-character ASCII string).
:CALCulate3:DATA?	Request detector #2 math reading.
:CALCulate3:STATe <state>	Enable/disable detector #2 math (ON or OFF).
:CALCulate3:KMATH:MBFactor 	Set detector #2 MX + B, B (offset) parameter.
:CALCulate3:KMATH:MMFactor <M>	Set detector #2 MX + B, M (slope) parameter.
:CALCulate3:KMATH:MUNits "<units>"	Define detector 2 MX + B units (1-character ASCII string).
:CALCulate4:DATA?	Request delta (detector #1 - detector #2 current reading).
:CALCulate4:STATe <state>	Enable/disable delta measurement (ON or OFF).
:FORMat:ELEMents <elements>	Select :READ? data elements (CURRent[1], VOLTage[1], CURRent2, VOLTage2, CURRent3, VOLTage3, STATus, or TIME). ²
:FORMat:ELEMents:CALCulate <elements>	Select CALC data elements (CALCulate, STATus, or TIME).
:INIT	Trigger readings.
:OUTPut[1] <state>	Turn all sources ON or OFF.
:READ?	Trigger and acquire readings.
:SENSe[1]:VOLTage:RANGe <range>	Set laser diode voltage measure range (5 or 10).
:SENSe[1]:VOLTage:POLarity <polarity>	Set laser diode measure polarity (POSITive or NEGative).
:SENSe2:CURRent:RANGe <range>	Set detector #1 measure range (0.01, 0.02, 0.05, 0.1).
:SENSe2:CURRent:POLarity <polarity>	Set detector #1 measure polarity.
:SENSe3:CURRent:RANGe <range>	Set detector #2 measure range (0.01, 0.02, 0.05, 0.1).
:SENSe3:CURRent:POLarity <polarity>	Set detector #2 measure polarity.

¹ COND = I_L/V_L ; RES = V_L/I_L ; POWER = $V_L * I_L$.

² CURR1 = I_L ; VOLT1 = V_L ; CURR2 = I_{PD1} ; VOLT2 = V_{B2} ; CURR3 = I_{PD3} ; VOLT3 = V_{B2} .

³ 5.0A maximum pulse mode only. 1A maximum in DC mode.

⁴ Settings affected by maximum duty cycle. See Section 5.

Table 4-2 (continued)

Laser diode test commands

Command	Description
:SOURce[1]:CURRent:MODE FIXEd	Select fixed (not sweep) laser diode current source mode.
:SOURce[1]:CURRent:RANGe <range>	Select laser diode source range (0.5 or 5).
:SOURce[1]:CURRent <current>	Set laser diode source current (0 to +5.0). ³
:SOURce[1]:CURRent:POLarity <polarity>	Set laser diode source polarity (POSitive or NEGative).
:SOURce[1]:VOLTage:PROTection <limit>	Set laser source voltage compliance limit (3 to 10.5).
:SOURce[1]:FUNction <function>	Select laser diode current source function (DC or PULSe).
:SOURce[1]:PULSe:DELay <delay>	Set laser diode source pulse delay (20e-6 to 0.5). ⁴
:SOURce[1]:PULSe:WIDTh <width>	Set laser diode source pulse width (500e-9 to 5e-3). ⁴
:SOURce[1]:CURRent:LOW <low_current>	Set low pulse amplitude for pulse mode (0 to 0.015, 500mA range; 0 to 0.150, 5A range).
:SOURce2:VOLTage <voltage>	Set detector #1 source voltage (0 to ±20).
:SOURce3:VOLTage <voltage>	Set detector #2 source voltage (0 to ±20).

¹ COND = I_L/V_L ; RES = V_L/I_L ; POWER = $V_L * I_L$.² CURR1 = I_L ; VOLT1 = V_L ; CURR2 = I_{PD1} ; VOLT2 = V_{B2} ; CURR3 = I_{PD3} ; VOLT3 = V_{B2} .³ 5.0A maximum pulse mode only. 1A maximum in DC mode.⁴ Settings affected by maximum duty cycle. See Section 5.

Programming example

Table 4-3 summarizes the command sequence for basic laser diode testing. Note that most steps correspond to those listed previously in “Front panel laser diode testing,” page 4-3. See Figure 4-1 for basic circuit configuration and Section 2 for detailed connection information.

These commands set up the Model 2520 as follows:

- Laser diode voltage measurement range and polarity: 10V, positive.
- Detector measurement polarity: negative (both detectors).
- Detector ranges: 10mA (detector #1); 50mA (detector #2).
- Laser diode source: 0.5A range, +0.5A amplitude, 5V voltage limit, positive polarity.
- Laser diode source mode: pulse, delay = 200µsec, width = 10µsec, low I = 10mA.
- Detector #1 bias source: +20V amplitude.
- Detector #2 bias source: +10V amplitude.
- Laser diode math function: power.
- Detector #1 math function: MX + B, B = 2, M = 0.5.
- Returned data: laser diode power, detector #1 MX + B math, detector #2 current.

NOTE See *Appendix H* for a functional program example.

Table 4-3

Basic laser diode test command sequence

Step ¹	Action	Commands ^{2,3}	Comments
1	Configure laser diode measure.	*RST :SENS1:VOLT:RANG 10	Restore GPIB defaults. LD measure range = 10V.
2	Configure detector measure.	:SENS1:VOLT:POL POS :SENS2:CURR:POL NEG :SENS3:CURR:POL NEG :FORM:ELEM CURR3	LD positive polarity. Det. #1 negative polarity. Det. #2 negative polarity. Det. #2 current data.
3	Configure laser source.	:SENS2:CURR:RANG 0.01 :SENS3:CURR:RANG 0.05 :SOUR1:CURR:RANG 0.5 :SOUR1:CURR 0.5 :SOUR1:VOLT:PROT 5 :SOUR1:CURR:POL POS :SOUR1:FUNC PULS :SOUR1:PULS:DEL 200e-6 :SOUR1:PULS:WIDT 10e-6 :SOUR1:CURR:LOW 10e-3	Det. #1 10mA range. Det. #2 50mA range. 0.5A LD source range. LD source output = 0.5A. 5V LD source voltage limit. LD source positive polarity. LD source pulse mode. 200µsec pulse delay. 10µsec pulse width. 10mA low current pulse.
4	Configure detector bias sources.	:SOUR2:VOLT 20 :SOUR3:VOLT 10	Det. #1 source output = 20V. Det. #2 source output = 10V.
5	Configure math functions.	:CALC1:FORM POWER1 :CALC2:KMAT:MBF 2 :CALC2:KMAT:MMF 0.5 :CALC1:STAT ON :CALC2:STAT ON	Select LD power math. Det. #1 B = 2. Det. #1 M = 0.5. Enable LD math function. Enable Det. #1 math.
6	Turn on outputs.	:OUTP1 ON	All source outputs on.
7	Trigger and read data.	:READ? :CALC1:DATA? :CALC2:DATA?	Trigger, get readings. Acquire LD math data. Acquire Det. #1 math data.
8	Turn off outputs.	:OUTP1 OFF	Outputs off after measuring.

¹Steps correspond to front panel steps previously in "Front panel laser diode testing," page 4-3.

²Commands must be sent in order given.

³Instrument must be addressed to talk after :READ?, :CALC1:DATA?, and :CALC2:DATA? to acquire data.

5

Source-Measure Concepts

- **Pulse concepts** — Describes the various aspects of the laser diode current source pulse mode.
- **Sweep operation** — Covers the various types of sweeps that can be performed.
- **Operating boundaries** — Covers output and limit operating boundaries for the laser diode current source.
- **Data flow** — Describes measurement readings and how data is stored in the buffer during a sweep.

Pulse concepts

Overview

The Model 2520 laser diode current source can output either DC or pulse waveforms. Maximum current is as follows:

- DC: 1A
- Pulse mode: 5A

In addition, the current source can be operated in either the fixed or sweep mode. In the fixed mode, the source simply outputs the programmed DC level (DC mode), or pulses at a fixed amplitude (pulse mode). In the sweep mode, the source DC or pulse amplitude can be swept across a series of steps at given increments. In addition, you can design your own sweep waveforms by using the custom (list) sweep mode. See “Sweep waveforms,” page 5-8, for more sweep information.

Delay-pulse cycle

Model 2520 laser diode current source and voltage measurements consist of a series of delay-pulse cycles (Figure 5-1). During each cycle, the following occurs:

1. Wait for the programmed delay period.
2. Output the programmed current pulse.
3. During the current pulse, the 10MHz A/D converter processes a number of raw voltage and current samples.
4. After the pulse, the raw samples are processed by a DSP (Digital Signal Processor) into one set of laser diode voltage and detector current readings.
5. Repeat the cycle.

Figure 5-1
Delay-pulse cycle

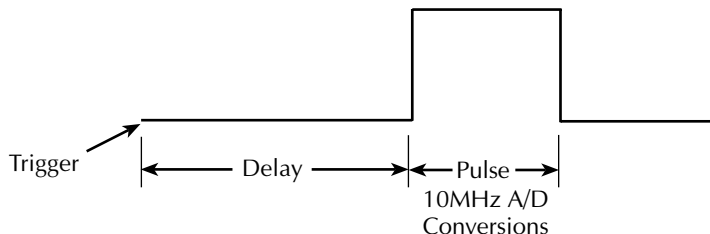

Delay phase

The programmable delay specifies the minimum time between two pulses (pulse off time) in a sweep. Note that data processing is part of the delay phase (Figure 5-1). The time needed for data processing is directly related to the length of the pulse phase. As the pulse width becomes large relative to the pulse delay, the actual time between pulses will depend more on the processing time rather than the programmable delay period.

The delay time for the sweep and fixed mode is defined as follows:

- For the list and sweep modes, the actual delay time is the same as the programmed delay period.
- For the fixed mode, the total delay is the sum of the programmed delay and the trigger latency.

Pulse phase

During the pulse phase, the unit outputs one current pulse at the specified amplitude with the programmed pulse width. Sampling on all three measurement channels (laser diode voltage; detector 1 and detector 2 current) is also performed during this phase. In the DC mode, the readings are taken during the pulse phase and then averaged. Pulse width therefore becomes the aperture or sample time of the system.

Duty cycle

The pulse duty cycle is defined as the ratio between the pulse on time (pulse phase) and the pulse off time (delay phase) expressed as a percentage:

$$DC = \frac{PW}{PW + PD} \times 100$$

Where: DC = duty cycle (%)

PW = pulse width (s)

PD = pulse delay (s)

NOTE *The Model 2520 will not output pulses at a duty cycle larger than 4% for currents more than 1A.*

Front panel pulse parameters

Fixed mode

Figure 5-2 shows how various front panel programming parameters control various fixed pulse waveform aspects. These parameters are programmed by pressing the appropriate key:

- **LASER I_L** — sets the pulse amplitude.
- **DELAY** — sets the pulse delay (time period between pulses).
- **PW** — sets the pulse width.

Figure 5-2

Front panel fixed mode pulse parameters

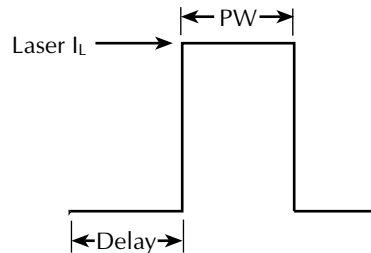

Staircase sweep mode

Figure 5-3 shows how various front panel programming parameters control various staircase sweep pulse waveform aspects. These parameters are programmed by pressing the appropriate key:

- **Pulse amplitudes:** determined by the programmed **START**, **STOP**, and **STEP** (or **# POINTS**) parameters in the **CONFIG SWEEP** menu.
- **DELAY** — sets the pulse delay (time between pulses).
- **PW** — sets the pulse width.
- **LOW** — This parameter, accessible in the **CONFIG LASER I_L** menu, sets the pulse low level. The pulse amplitude returns to this level during the pulse delay unless the pulse amplitude is below the low level, in which case the level is set to 0A.

Figure 5-3
Front panel staircase sweep mode pulse parameters

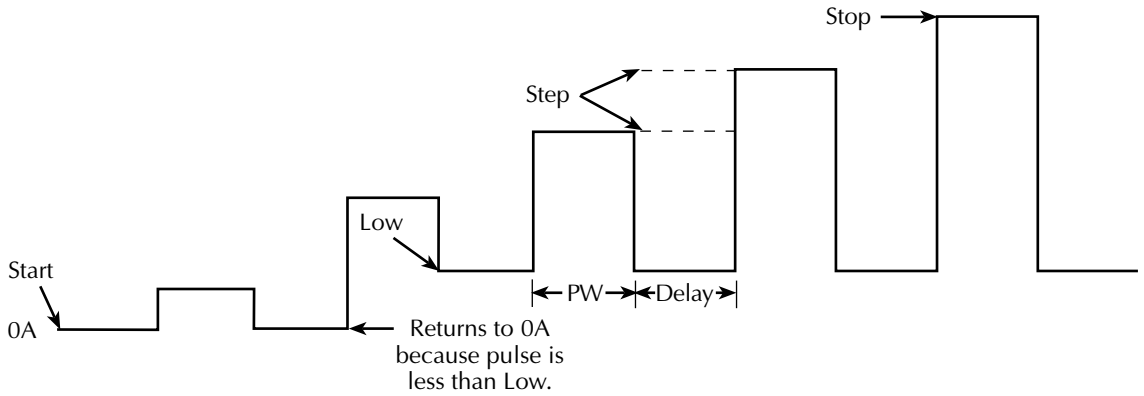
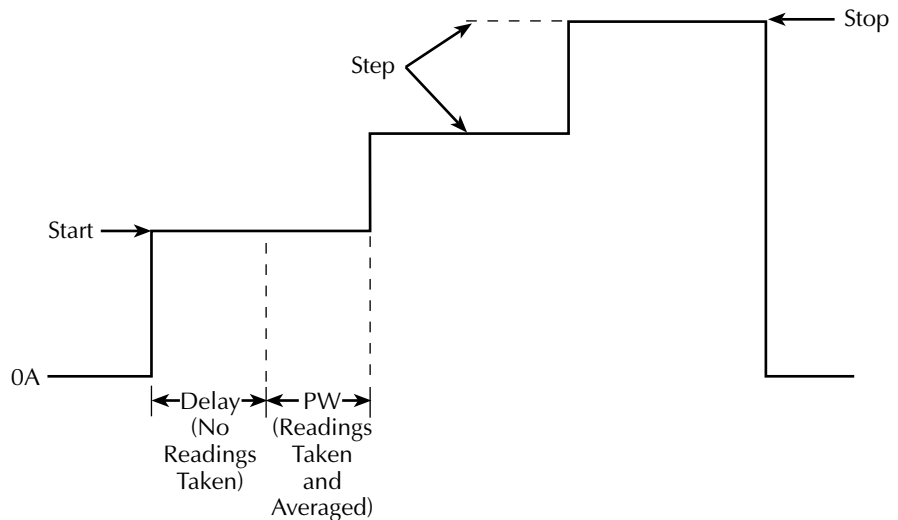

Figure 5-4 shows how various front panel programming parameters control various staircase sweep DC waveform aspects. These parameters are programmed by pressing the appropriate key:

- Pulse amplitudes: determined by the programmed START, STOP, and STEP (or # POINTS) parameters in the CONFIG SWEEP menu.
- DELAY + PW: determines the time at each step.

Figure 5-4
Front panel staircase sweep mode DC parameters



Remote pulse parameters

Fixed mode

Figure 5-5 shows how various remote commands control various fixed pulse waveform aspects. These parameters are programmed as follows:

- **SOUR1:CURR** — sets the pulse amplitude.
- **SOUR1:PULS:DEL** — sets the pulse delay (time between pulses).
- **SOUR1:PULS:WIDT** — sets the pulse width.

Figure 5-5

Remote fixed mode pulse parameters

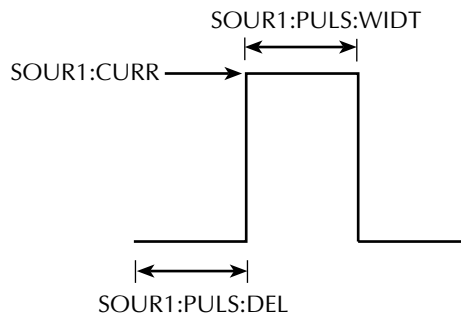

Staircase sweep mode

Figure 5-6 shows how various front panel programming parameters control various staircase sweep pulse waveform aspects. These parameters are programmed by sending the appropriate command:

- **Pulse amplitudes** — determined by parameters programmed with **SOUR1:CURR:STAR**, **SOUR1:CURR:STOP**, and **:SOUR1:CURR:STEP** (or **SOUR1:SWE:POINT** for LOG sweep) commands.
- **SOUR1:PULS:WIDT** — sets the pulse width.
- **SOUR1:PULS:DEL** — sets the pulse delay (time between pulses).
- **SOUR1:CURR:LOW** — This command sets the pulse low level. The pulse amplitude returns to this level during the pulse delay unless the pulse amplitude is below the low level, in which case the level is set to 0A.

Figure 5-6
Remote staircase sweep mode pulse parameters

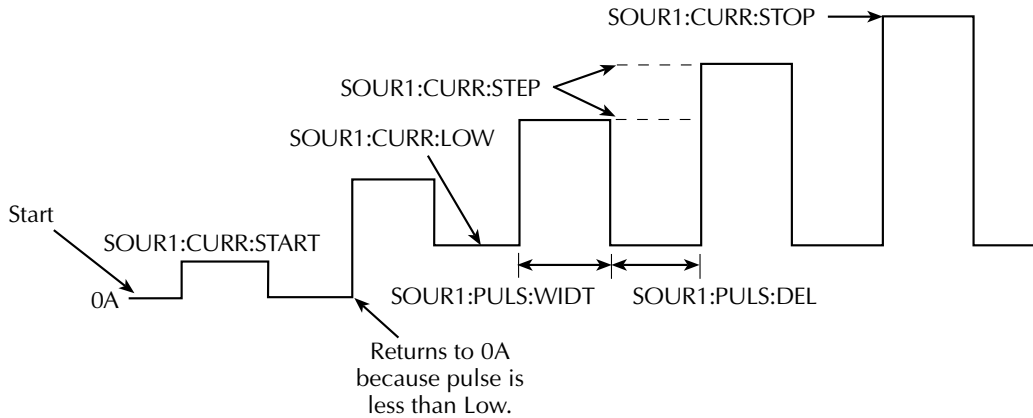

Pulse rise and fall times

As shown in [Figure 5-7](#), there are two additional pulse characteristics that require discussion: rise time and fall time. (Characteristics are exaggerated for clarity.) Note that these characteristics depend on cable connection configuration, setting and range, load, and operating mode. See the specifications in [Appendix A](#) for details.

Figure 5-7
Pulse characteristics

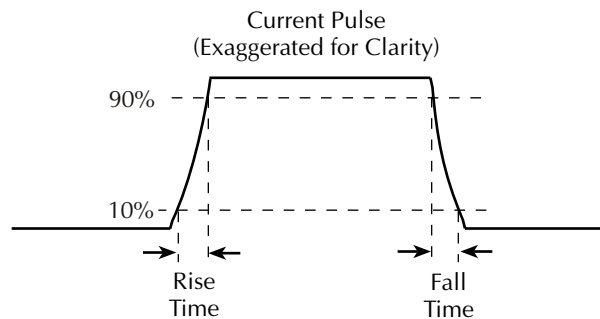

The rise and fall times of the current source pulse can be controlled with the `:SOURce1:PULSe:TRANsition` command, as covered in “[SOURce subsystem](#),” page [14-32](#). This command allows you to increase the rise time of the pulse. Increasing the rise time will help reduce overshoot and/or oscillations that could occur when long cables are used, or if poor connections are present in the test setup.

Sweep waveforms

There are three basic sweep types available: linear staircase, logarithmic staircase, and custom.

NOTE Staircase sweeps can be programmed both from the front panel and via remote, while custom sweeps are available only via remote.

Staircase sweeps

As shown in [Figure 5-8](#), the linear staircase sweep goes from the start level to the stop level in equal linear steps. The logarithmic staircase sweep is similar except it is done on a log scale with a specified number of steps per decade.

For the DC mode, the current will remain at a fixed amplitude for the duration of each sweep point. For the pulse mode, the current will remain at the sweep step amplitude for the programmed pulse width, and the time between steps depends on the programmed delay.

NOTE The duration of each step is the sum of the programmed pulse width and pulse delay times for both DC and pulse sweeps.

See [Section 7](#) for more details on staircase sweep operation. See also the SOUR1:CURR and SOUR1:SWE commands under “[SOURCE subsystem](#),” [page 14-32](#), for information on programming staircase sweeps via remote.

Custom sweep

The custom sweep lets you construct your own sweep by specifying the number of source-measure points (100 maximum) and the current source level, pulse width, and pulse delay at each point ([Figure 5-9](#)).

The SOUR1:LIST commands program various custom sweep parameters, including:

- **SOUR1:LIST:CURR** — Sets up a custom sweep list with up to 100 current values.
- **SOUR1:LIST:WIDT** — Specifies up to 100 pulse width values for a custom sweep.
- **SOUR1:LIST:DEL** — Specifies up to 100 pulse delay values for a custom sweep.

NOTE If the delay or width list is shorter than the current list, the last delay or width value will be used for the remainder of the current list points.

See the custom sweep information in [Section 7](#) and the LIST commands under “[SOURCE subsystem](#),” [page 14-32](#), for details.

Figure 5-8
Sweep waveform types

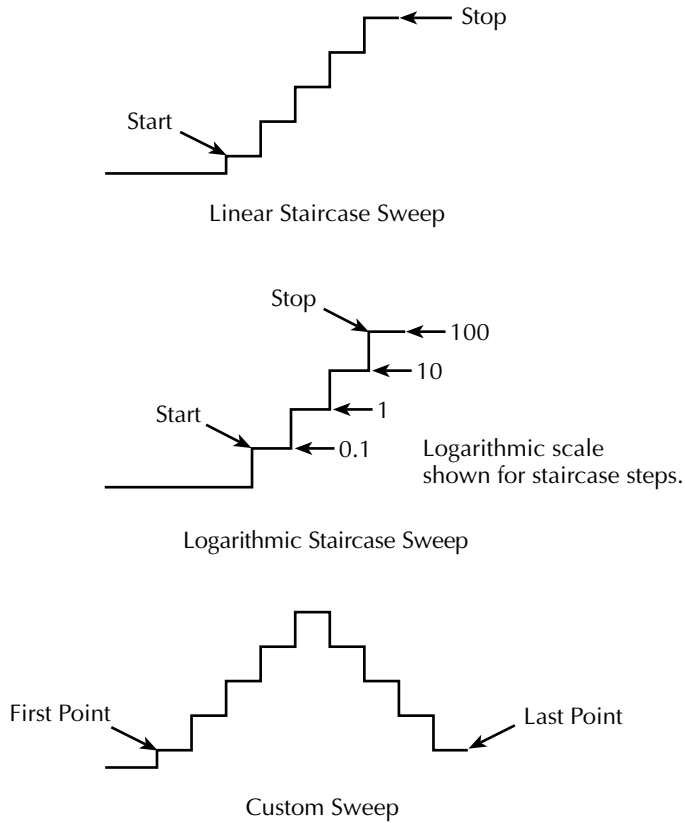

Note: DC mode waveforms shown.

Figure 5-9
Custom sweep waveform

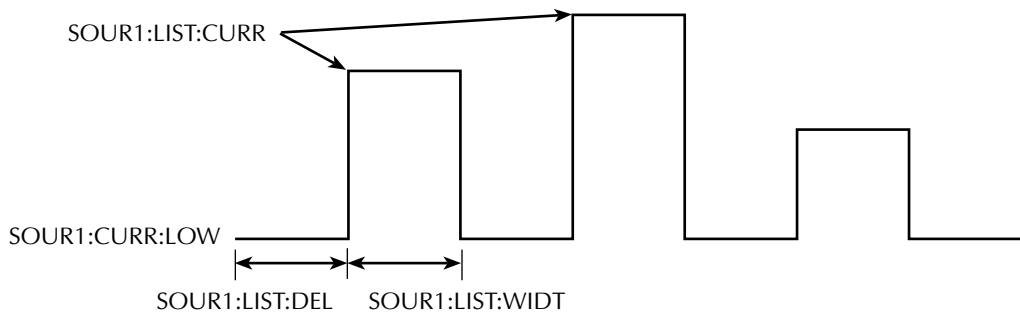

Current source operating boundaries

Limit lines

Figure 5-10 shows the operating boundaries, or limit lines for the laser diode current source. In the DC mode, the current source can output a maximum of 1A @ 9.9V. In the pulse mode, the current source can output 5A @ 9.5V. The voltage compliance (limit) can be set over a range of 3V to 10.5V. The compliance voltage is sensed at the pulser circuit board, so any I/R drops in the cables or connections is not sensed, and no corrections are made for these resistances.

Figure 5-10
Current source limit lines

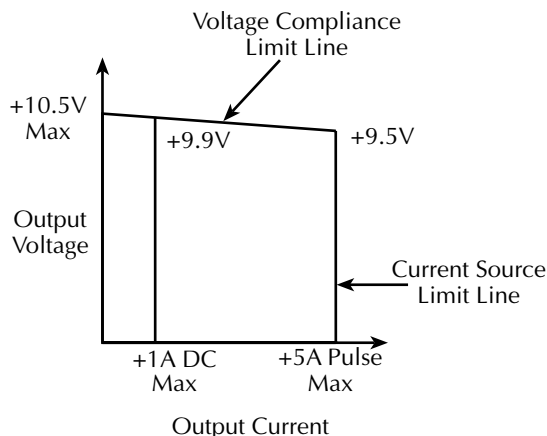

Loading effects

Where within the boundaries each Model 2520 current source operates depends on the resistance of the load (DUT) that is connected to the output. Figure 5-11 shows operation examples for resistive loads that are 50 Ω and 125 Ω , respectively. For these examples, the Model 2520 current source is programmed to source 100mA with a voltage limit of 10.5V.

In Figure 5-11A, the Model 2520 is sourcing 100mA into the 50 Ω load and subsequently develops 5V across the load resistance. As shown, the load line for 50 Ω intersects the 100mA current source line at 5V.

Figure 5-11B shows what happens if the resistance of the load is increased to 125 Ω . The DUT load line for 125 Ω intersects the 10.5V compliance limit line placing the Model 2520 in compliance. In compliance, the Model 2520 will not be able to source its programmed current (100mA). For the 125 Ω DUT, the unit will output only 80mA (at the programmed 10.5V limit).

Figure 5-11
Loading effects

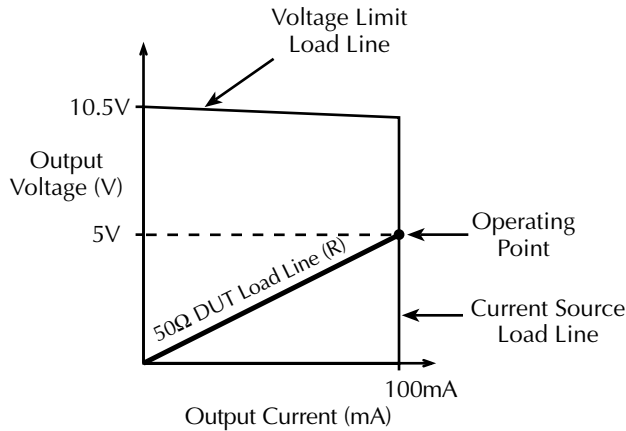

$$\begin{aligned}
 V &= I \cdot R \\
 &= (100\text{mA})(50\Omega) \\
 &= 5\text{V}
 \end{aligned}$$

A. Normal Current Source Operation

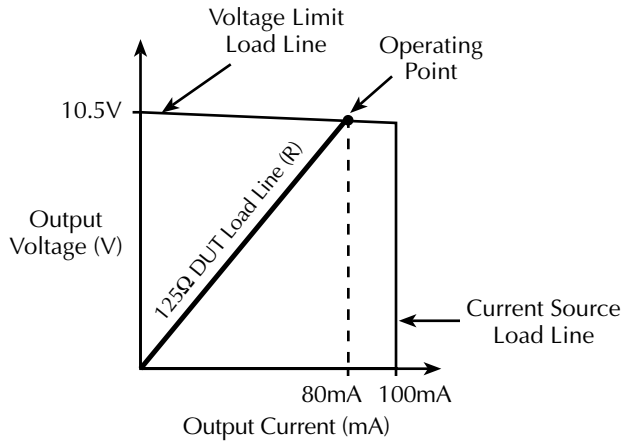

$$\begin{aligned}
 I &= V/R \\
 &= 10\text{V}/125\Omega \\
 &= 80\text{mA}
 \end{aligned}$$

B. Current Source in Compliance

Notice that as resistance increases, the slope of the DUT load line increases. As resistance approaches infinity (open output), the Model 2520 will source virtually 0mA at 10.5V. Conversely, as resistance decreases, the slope of the DUT load line decreases. At zero resistance (shorted output), the Model 2520 will source virtually 100mA at 0V.

Regardless of the load, voltage will never exceed the programmed compliance of 10.5V.

In the constant-current mode, the output impedance is extremely high. When the compliance voltage is exceeded, however, the source operates more like a voltage source with a finite output impedance. The open-circuit (compliance) voltage is programmable from 3V to 10.5V, and the nominal output impedance is 0.1Ω. As a result, the clamping voltage at the DUT will be lower than the compliance value by the following amount:

$$V_{\text{clamp at DUT}} = I_{\text{LD}} \times (0.1\Omega + R_{\text{cable}} + R_{\text{fixture}})$$

Data flow

Data flow for front panel operation is summarized by the block diagrams provided in [Figure 5-12](#).

NOTE See [Appendix C](#) for remote operation data flow information, as well as a diagnostic tool that allows you to access raw samples.

Basic reading display

With sweeps and math disabled ([Figure 5-12A](#)), the Model 2520 displays the configured laser diode voltage and detector current readings.

Math function display

With a math function enabled ([Figure 5-12B](#)), the Model 2520 displays the configured math functions. Laser diode math functions include V/I (resistance), I/V (conductance), power, and MX + B, while only MX + B is available for the two photodiode detector channels.

Sweep data storage

[Figure 5-12C](#) shows data flow when a sweep is enabled. All data is stored in the buffer while the sweep is in process. When the recall mode is activated by pressing the RECALL key, data comes from the buffer. Data includes laser diode source current and voltage measurement, detector current measurements, and buffer location number.

If the math function is enabled, math readings will be processed and displayed for each buffer location instead of basic voltage and current readings.

Figure 5-12
Data flow-front panel

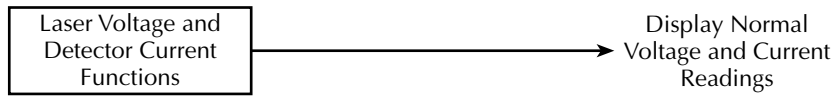

A. Math Function and Sweeps Disabled

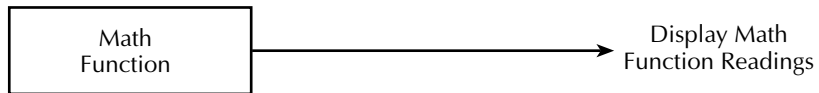

B. Math Function Enabled

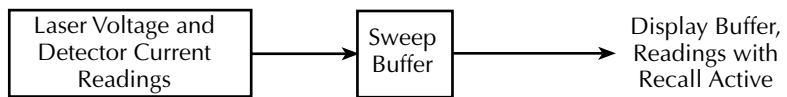

C. Sweep Enabled

6 Range, Filter, and Math

- **Range** — Discusses available ranges, maximum readings and source values, and ranging limitations.
- **Filter** — Provides information on the filtering process that can be used to reduce reading noise.
- **Math** — Outlines the math functions that can be performed on laser diode voltage measurement and photodiode current measurement data.

Range

Measurement ranges

The selected measurement range affects the accuracy of the laser diode voltage measurements, photodiode detector current measurements, as well as the maximum signal that can be measured.

Laser diode voltage ranges

Table 6-1 summarizes laser diode voltage ranges, resolution, and maximum readings.

Table 6-1

Laser diode voltage measurement ranges

Voltage range	Resolution	Maximum reading
5V	0.33mV	±5.25V
10V	0.66mV	±10.5V

Photodiode detector current ranges

Table 6-2 lists the available current measurement ranges, resolution values, and maximum readings for each Model 2520 photodiode detector.

NOTE The current measurement range can be individually set for each detector.

Table 6-2

Photodiode current measurement ranges

Current range	Resolution	Maximum reading
10mA	0.7μA	±10.5mA
20mA	1.4μA	±21mA
50mA	3.4μA	±52.5mA
100mA	6.8μA	±105mA

Maximum readings

The full scale input for each measurement range is shown in [Table 6-1](#) and [Table 6-2](#). Input levels that exceed the maximum levels cause the “Oflow” message to be displayed.

Setting the measurement range

Press the LASER V_L , DETECTOR 1 I_{PD} or DETECTOR 2 I_{PD} key, then use the RANGE ▲ and ▼ keys to select a range.

NOTE Use the lowest range possible without causing an overflow to ensure best accuracy and resolution.

Source ranging

As summarized in [Table 6-3](#), the laser diode current source has two ranges. To set the range, press the LASER I_L and EDIT keys, then use the RANGE ▲ and ▼ keys.

Table 6-3
Laser diode current source ranges

Current range	Resolution	Maximum output
500mA	10 μ A	500mA
5A	100 μ A	5.0A*

* Pulse mode only. 1A maximum in DC mode.

Remote range programming

[Table 6-4](#) summarizes the commands necessary to control range. See “SENSE subsystem,” [page 14-27](#), for more details on these commands.

Table 6-4
Range commands

Commands	Description
[[:SENSe[1]]:VOLTage:RANGe <range> :SENSe2:CURRent:RANGe <range> :SENSe3:CURRent:RANGe <range> :SOURce[1]:CURRent:RANGe <range>	Set laser diode voltage measure range (5 or 10). Set photodiode 1 current measure range (0.01, 0.02, 0.05, or 0.1). Set photodiode 2 current measure range (0.01, 0.02, 0.05, or 0.1). Set laser diode current source range (0.5 or 5).

Range programming example

Table 6-5 shows a programming example for controlling range. The Model 2520 is set up as follows:

- Laser diode voltage measure range: 5V.
- Laser diode current source range: 500mA.
- Detector 1 current range: 10mA.
- Detector 2 current range: 100mA.

Table 6-5

Range programming example

Command	Description
*RST	Restore GPIB defaults.
:SENS1:VOLT:RANG 5	5V laser diode measure range.
:SOUR1:CURR:RANG 0.5	500mA laser diode source range.
:SENS2:CURR:RANG 10e-3	10mA detector 1 current range.
:SENS3:CURR:RANG 100e-3	100mA detector 2 current range.
:OUTP1 ON	Turn on outputs.
:READ?	Trigger and acquire readings.
:OUTP1 OFF	Turn off outputs.

Filter

Filtering stabilizes noisy measurements caused by noisy input signals. The Model 2520 uses an averaging type filter for all three measurements. The number of readings averaged can be set between 1 and 100. However, the more filtering that is used (higher number of readings averaged), the slower the measurement process becomes.

Averaging filter overview

When the averaging filter is enabled, the unit cycles through the complete delay-pulse cycle for each filter sample measurement. (See Section 5 for delay-pulse details.) The measurement results for all delay-pulse cycles are then averaged to give one “filtered” reading.

If the filter is enabled in sweep mode (See Section 7), each step of the sweep will effectively be repeated for the filter count number of times. Figure 6-1 shows an example of a sweep from 10mA to 30mA with a filter count of 3. Note that three delay-pulse cycles are performed at each step. In this example, three readings per measurement channel will be returned by a READ? query.

Figure 6-1
Averaging filter during sweep

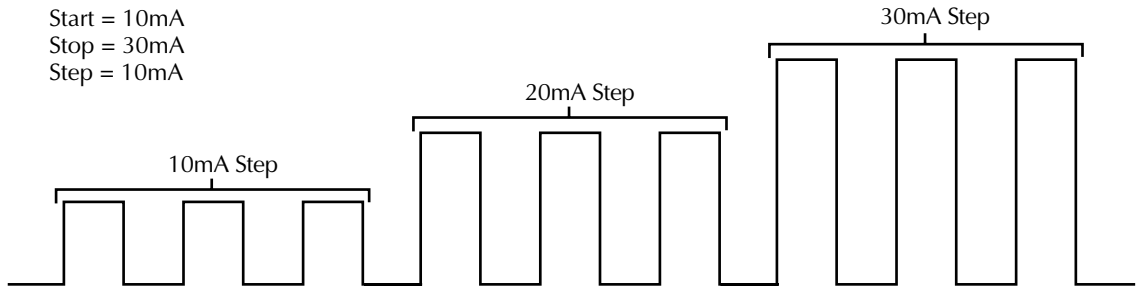

With filter count = 3, three delay-pulse cycles are performed at each sweep step.

Filter configuration

NOTE *The average filter setting is global and affects all three measurements (laser diode voltage and both detector current measurements).*

1. Press the CONFIG key and then the FILTER key to access the filter configuration menu.
2. Use the EDIT ◀, ▶, ▲ and ▼ keys to set the display to the desired count (1 to 100), and press ENTER.

Filter control

When filtering is being applied to the measured signals, the FILT annunciator will be on. The FILTER key is used to control filtering. Pressing FILTER turns on the FILT annunciator to indicate that the filter configuration is being applied to all three measurements. Pressing FILTER a second time turns the FILT annunciator off to indicate that filtering is turned off.

Remote filter programming

Filter command

Table 6-6 summarizes filter commands. See “SENSE subsystem,” page 14-27, for more details.

NOTE Filter commands are global. Changing the setting using the commands for one measurement function affects filtering for the other two functions.

Table 6-6

Filter commands

Commands	Description
[[:SENSe[1]]:AVERage:COUNT <count> [:SENSe[1]]:AVERage[:STATe] <state> :SENSe2:AVERage:COUNT <count> :SENSe2:AVERage[:STATe] <state> :SENSe3:AVERage:COUNT <count> :SENSe3:AVERage[:STATe] <state>	Set average filter count (1 to 100). Enable/disable average filter (ON or OFF). Set average filter count (1 to 100). Enable/disable average filter (ON or OFF). Set average filter count (1 to 100). Enable/disable average filter (ON or OFF).

Filter programming example

Table 6-7 summarizes the command sequence to program filter aspects as follows:

- Average filter on.
- Average filter count 20.

Table 6-7

Filter programming example

Command	Description
:AVER:COUNT 20	Set average count to 20.
:AVER ON	Enable average filter.

Measurement math functions

The Model 2520 has built-in math functions to calculate the following:

- Conductance
- Resistance
- $MX + B$
- Power
- Delta

NOTE Conductance, resistance, and power are available only for laser diode voltage measurements. $MX + B$ is available for all three measurement functions (laser diode voltage and both detector current measurements).

Conductance

This math function computes the conductance from the ratio between the laser diode current source value and the measured voltage:

$$\text{Conductance} = I_L/V_L$$

where: I_L = laser diode source current

V_L = measured laser diode voltage

Resistance

This math function computes the resistance using the ratio between the measured laser diode voltage and the source current:

$$\text{Resistance} = V_L/I_L$$

where: V_L = laser diode voltage measurement

I_L = laser diode source current

Power

This math function calculates power using the measured voltage and source current values as follows:

$$\text{Power} = V_L \times I_L$$

where: V_L = laser diode voltage measurement

I_L = laser diode source current

MX + B

This math function multiplies the measured laser diode voltage or photodiode detector current by an offset factor and adds an offset value as follows:

$$\text{Reading} = MX + B$$

where: M = gain (slope) factor

X = measured laser diode voltage (V_L) or photodiode current (I_{PD})

B = offset value

Delta (remote only)

This math function computes the difference between detector #1 and detector #2 current:

$$\text{Delta} = I_{PD1} - I_{PD2}$$

The calculation is performed point-by-point on individual A/D samples, not on the final current measurement. Delta is available using the CALC4 subsystem (See [Section 14](#)).

Front panel math functions

Math configuration menu

Table 6-8 summarizes the math configuration menu. Press CONFIG then MATH to access the menu.

Table 6-8

Math configuration menu

Configuration menu item	Description
CONFIGURE MATH	
CHANNEL1	Program V_L (laser diode voltage) math function.
I/V	Select conductance function (I_L/V_L).
V/I	Select resistance function (V_L/I_L).
MX+B_UNIT	Select MX + B function, program M, B and units.
P ζ	Select power function ($V_L \times I_L$).
CHANNEL2	Program photodiode detector #1 MX + B, M, B, and units.
CHANNEL3	Program photodiode detector #2 MX + B, M, B, and units.

Programming math functions

Follow these steps to program math functions:

1. Press CONFIG then MATH to access the math configuration menu.
2. Select the CHANNEL to be configured, then press ENTER.
3. For CHANNEL1 only, select the math function.
4. When programming the MX + B function for all three channels, enter the M and B values, and the units at the successive prompts, and press ENTER after each entry.

Remote math functions

Math function commands

Table 6-9 summarizes commands to control the measurement math functions by remote. See “Calculate subsystems,” page 14-14, for detailed information.

Table 6-9

Math function commands

Command	Description
:CALCulate[1]:DATA?	Request laser diode math reading.
:CALCulate[1]:FORMat <function>	Set laser diode math function (MXB[1], CONDUCTance[1], POWER[1], or RESistance[1]).
:CALCulate[1]:KMATH:MBFactor 	Set laser diode MX + B offset (B) value.
:CALCulate[1]:KMATH:MMFactor <M>	Set laser diode MX + B slope (M) value.
:CALCulate[1]:KMATH:MUNits “<units>”	Set 1-character MX + B units suffix.
:CALCulate[1]:STATe <state>	Enable/enable laser diode math (ON or OFF).
:CALCulate2:DATA?	Request detector #1 math reading.
:CALCulate2:KMATH:MBFactor 	Set detector #1 MX + B offset (B).
:CALCulate2:KMATH:MMFactor <M>	Detector #1 MX + B slope (M).
:CALCulate2:KMATH:MUNits “<units>”	Set 1-character MX + B units suffix.
:CALCulate2:STATe <state>	Enable/enable detector #1 math (ON or OFF).
:CALCulate3:DATA?	Request detector #2 math reading.
:CALCulate3:KMATH:MBFactor 	Set detector #2 MX + B offset (B).
:CALCulate3:KMATH:MMFactor <M>	Detector #2 MX + B slope (M).
:CALCulate3:KMATH:MUNits “<units>”	Set 1-character MX + B units suffix.
:CALCulate3:STATe <state>	Enable/enable detector #2 math (ON or OFF).
:CALCulate4:DATA?	Request delta (detector #1 current - detector #2 current).
:CALCulate4:STATe <state>	Enable/disable delta (ON or OFF).
:INIT	Trigger CALC readings (must use before sending CALCn:DATA?).

Math function programming example

Table 6-10 summarizes commands that program the following math function parameters:

- Laser diode math function: power
- Detector #1 MX + B slope (M): 0.5
- Detector #1 MX + B offset (B): 5e-3

Table 6-10

Math function programming example

Command	Description
:CALC1:FORM POWER1	Select laser diode power function.
:CALC1:KMAT:MUN 'W'	Set "W" math units.
:CALC1:STAT ON	Enable laser diode math.
:CALC2:KMAT:MBF 5e-3	Detector #1 MX + B offset (B) = 5e-3.
:CALC2:KMAT:MMF 0.5	Detector #1 slope (M) = 0.5.
:CALC2:STAT ON	Enable detector #1 math.
:OUTP1 ON	Turn on outputs.
:INIT	Trigger math readings.
:CALC1:DATA?	Request laser diode power result.
:CALC2:DATA?	Request detector #1 MX + B result.
:OUTP1 OFF	Outputs off.

7

Sweep Operation

- **Sweep types** — Describes the three basic sweep types: Linear staircase, logarithmic staircase, and custom sweep.
- **Configuring and running a sweep** — Discusses the procedure for setting up and performing sweeps including selecting and configuring a sweep and performing a sweep.

Sweep types

The three basic sweep types described in the following paragraphs include:

- Linear staircase
- Logarithmic staircase
- Custom

NOTE *Linear and logarithmic staircase sweeps are available both from the front panel and via remote. Custom sweeps can be performed only via remote.*

Linear staircase sweep

As shown in [Figure 7-1](#), this sweep steps from a start current source value to an ending (stop) current source value. Programmable parameters include the start, stop, and step source current levels. (This example shows the DC mode of operation.)

When this sweep is triggered to start, the current source output will go to the start source current level. The output will then change in equal steps until the stop source level is reached. The time duration at each step is determined by the time it takes to perform the measurement, which includes both the pulse width and the pulse delay.

Figure 7-1
Linear staircase sweep

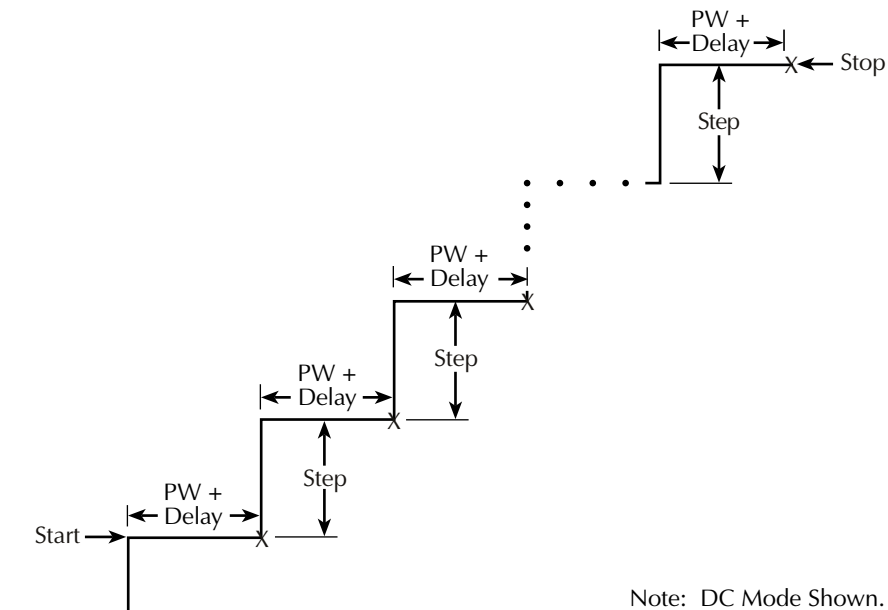

Note: DC Mode Shown.

Logarithmic staircase sweep

This sweep is similar to the linear staircase sweep. The steps, however, are done on a logarithmic scale as shown in the example sweep in [Figure 7-2](#). This is a 5-point log sweep from 1mA to 10mA. As with the staircase sweep, the measurement time is the same for all steps. (Again, DC mode waveforms are shown.)

Figure 7-2

Logarithmic staircase sweep

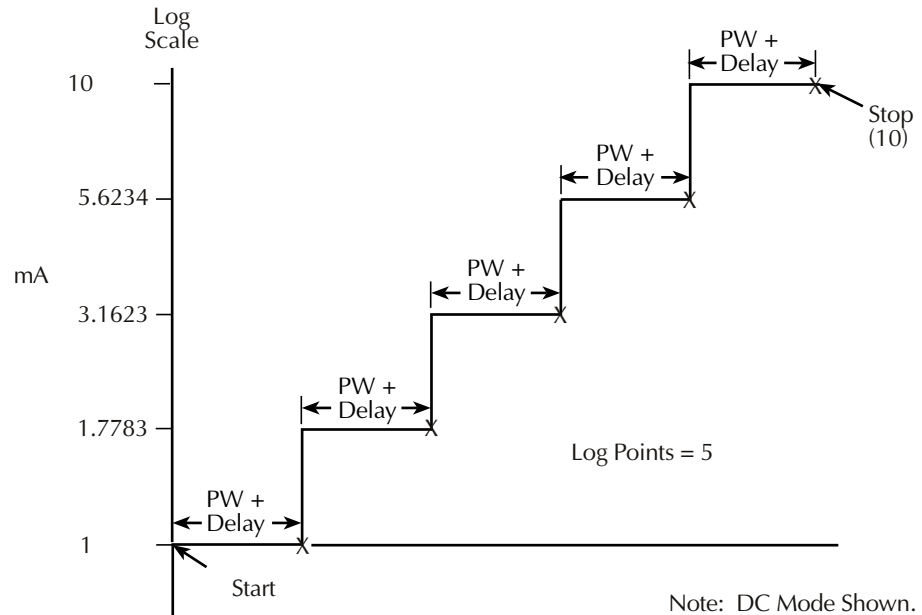

The programmable parameters for a log sweep include the start and stop levels and the number of measurement points for the sweep. The specified start, stop, and point parameters determine the logarithmic step size for the sweep. Step size for the sweep in [Figure 7-2](#) is calculated as follows:

$$\begin{aligned}
 \text{Log Step Size} &= \frac{\log_{10}(\text{stop}) - \log_{10}(\text{start})}{\text{Points} - 1} \\
 &= \frac{\log_{10}(10) - \log_{10}(1)}{5 - 1} \\
 &= \frac{(1 - 0)}{4} \\
 &= 0.25
 \end{aligned}$$

Thus, the five log steps for this sweep are 0, 0.25, 0.50, 0.75, and 1.00mA. The actual current source levels at these points are listed in [Table 7-1](#) (the current level is the anti-log of the log step).

Table 7-1
Logarithmic sweep points

Measure point	Log step	Current level (mA)
Point 1	0	1
Point 2	0.25	1.7783
Point 3	0.50	3.1623
Point 4	0.75	5.6234
Point 5	1.0	10

When this sweep is triggered to start, the output will go to the start source current level (1mA) and sweep through the symmetrical log points. The time duration at each step is determined by the time it takes to perform the measurement, which includes the pulse delay time.

Custom sweep

This sweep type lets you configure a customized sweep (via remote only). Programmable sweep list parameters include the number of measurement points in the sweep, the current source level at each point, pulse width, and pulse delay.

[Figure 7-3](#) shows an example of a custom sweep. When this sweep is started, the output goes to the first current level in the sweep after the delay period. The pulse period and time between pulses is determined by the programmed pulse and delay parameters. The sweep will continue through the points in the order they were programmed and stop after the last current point.

The size of the current list determines the custom sweep size. Normally, the pulse width list and delay list should be the same size as the current list. However, if the pulse width and/or pulse delay list is shorter than the current list, the last pulse width and/or delay point will be used for all subsequent current values.

Figure 7-3
Custom pulse sweep

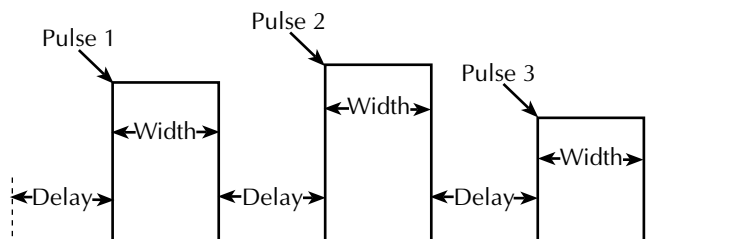

Configuring and running a sweep

Front panel sweep operation

Configuring a sweep

The sweep configuration menu is structured as follows and shown in [Figure 7-4](#). Note that bullets indicate the primary items of the sweep menu and dashes indicate the options of each menu item. Using [Section 1, “Rules to navigate menus,”](#) go through the following menu to select and configure the desired sweep.

CONFIGURE SWEEPS menu:

Press CONFIG then SWEEP to display the sweep configuration menu.

- **TYPE** — Use this menu item to select the type of sweep:
 - NONE — Disables all sweeps.
 - STAIR — When the linear staircase sweep is selected, you will be prompted to enter the START, STOP, and STEP levels.
 - LOG — When the logarithmic staircase sweep is selected, you will be prompted to enter the START and STOP levels and specify the NO OF POINTS (number of measurement points).
- **SWEEP-COUNT** — Use this menu item to specify how many sweeps to perform:
 - FINITE — Use this option to enter a discrete number of sweeps to perform with the results stored in the data store buffer. The maximum number of finite sweeps that can be performed is determined as follows:
 - maximum finite sweep count = $1000 / \# \text{ Points in sweep}$.
 - INFINITE — Select this option to continuously repeat the configured sweep. Use the EXIT key to stop the sweep. Data is not stored in the buffer.

Figure 7-4
Sweep configuration menu tree

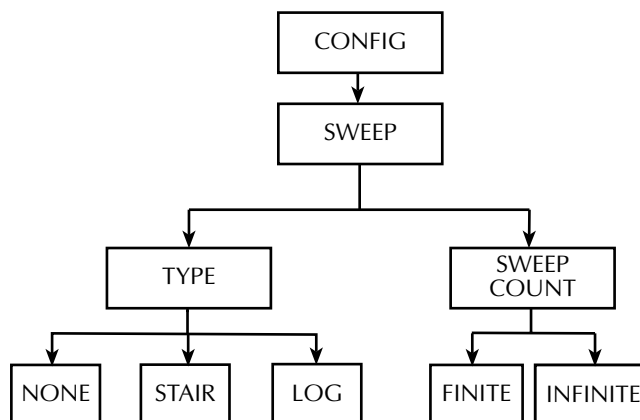

Performing sweeps

Procedures for the various sweep types are covered below.

NOTE The following procedure assumes that the Model 2520 is already connected to the DUT as explained in [Section 2](#).

Performing a linear staircase sweep

Step 1: Configure source and measure.

Configure the Model 2520 source and measure functions as follows:

1. Select the current source range by pressing LASER I_L then EDIT, then use the RANGE keys.
2. Press LASER V_L , then choose the desired measurement range.
3. Use the DETECTOR 1 V_B and DETECTOR 2 V_B keys, and EDIT keys to set the photodiode bias voltages to the desired values.
4. Set the current measurement ranges by pressing the DETECTOR 1 I_{PD} , DETECTOR 2 I_{PD} , and RANGE keys.

See [Section 3](#), “Basic circuit configuration,” for more information.

Step 2: Configure sweep.

Configure the sweep as follows:

1. Press CONFIG then SWEEP.
2. Select TYPE, then press ENTER.
3. Select STAIR, then press ENTER.
4. At the prompts, enter the desired START, STOP, and STEP values.
5. From the CONFIGURE SWEEPS menu, select SWEEP COUNT, press ENTER, then choose FINITE or INFINITE as desired.
6. Press EXIT to return to normal display.

Step 3: Turn outputs on.

Press the ON/OFF OUTPUT key to turn the outputs on (blue OUTPUT indicator turns on). The Model 2520 will output the photodiode bias voltages.

Step 4: Run sweep.

To run the sweep, press the SWEEP key. After the sweep is completed, turn the output off by pressing the ON/OFF OUTPUT key.

Step 5: Read buffer.

Use the RECALL key to access the readings stored in the buffer.

Performing a log staircase sweep

Step 1: Configure source and measure.

Configure the Model 2520 source and measure functions as follows:

1. Select the current source range by pressing LASER I_L then EDIT, then use the RANGE keys.
2. Press LASER V_L , then choose the desired measurement range.
3. Use the DETECTOR 1 V_B and DETECTOR 2 V_B keys, and EDIT keys to set the photodiode bias voltages to the desired values.
4. Set the current measurement ranges by pressing the DETECTOR 1 I_{PD} , DETECTOR 2 I_{PD} , and RANGE keys.

Step 2: Configure sweep.

Configure the sweep as follows:

1. Press CONFIG then SWEEP.
2. Select TYPE then press ENTER.
3. Select LOG then press ENTER.
4. At the prompts, enter the desired START, STOP, and NO-OF-POINTS values.
5. From the CONFIGURE SWEEPS menu, select SWEEP COUNT, press ENTER, then choose FINITE or INFINITE as desired.
6. Press EXIT to return to normal display.

Step 3: Turn outputs on.

Press the ON/OFF OUTPUT key to turn the outputs on (blue OUTPUT indicator turns on). The Model 2520 will output the photodiode bias voltages.

Step 4: Run sweep.

To run the sweep, press the SWEEP key. After the sweep is completed, turn the output off by pressing the ON/OFF OUTPUT key.

Step 5: Read buffer.

Use the RECALL key to access the readings stored in the buffer.

Remote sweep operation

Staircase sweep commands

Table 7-2 summarizes remote commands used for linear and log staircase sweep operation. See Section 14, “Configure sweeps,” for more details on these commands.

Table 7-2

Linear and log staircase sweep commands

Command	Description*
:SOURce[1]:CURRent:MODE SWEEp	Select staircase sweep mode.
:SOURce[1]:CURRent:START <current>	Specify sweep start current (0 to 5.0).
:SOURce[1]:CURRent:STOP <current>	Specify sweep stop current (0 to 5.0).
:SOURce[1]:CURRent:STEP <current>	Specify sweep step current (0 to 5.0).
:SOURce[1]:CURRent:CENTEr <current>	Specify sweep center current (0 to 5.0).
:SOURce[1]:CURRent:SPAN <current>	Specify sweep span current (0 to 5.0).
:SOURce[1]:SWEep:SPACing <type>	Select staircase sweep type (LINEar or LOGarithmic).
:SOURce[1]:SWEep:POINts <points>	Set number of sweep points (2 to 1000).
:SOURce[1]:SWEep:DIRectioN <direction>	Set sweep direction. UP (sweep start to stop) or DOWN (sweep stop to start).

* Maximum DC mode current is 500mA. Maximum pulse mode current is 5A.

Staircase sweep programming example

As an example of linear staircase sweep operation, assume the Model 2520 is to be used to test a laser diode. For the purposes of this test, assume the following basic sweep parameters:

- Source mode: sweep
- Start current: 10mA
- Stop current: 100mA
- Step current: 10mA

Table 7-3 lists the command sequence for laser diode programming example. See Section 2, “Connections” for details on how to connect the laser diode for the test.

NOTE See Appendix H for a functional program example.

Table 7-3

Linear staircase sweep programming example

Command	Description
*RST	Restore GPIB default conditions.
:FORM:ELEM	Laser diode voltage, detector current data.
VOLT1,CURR2,CURR3	
:SENS1:VOLT:RANG 5	5V measure range.
:SOUR1:CURR:RANG 0.5	500mA source range.
:SOUR1:CURR:STAR 10e-3	10mA start current.
:SOUR1:CURR:STOP 100e-3	100mA stop current.
:SOUR1:CURR:STEP 10e-3	10mA step current.
:SOUR1:CURR:MODE SWE	Select staircase sweep mode. ¹
:SOUR1:SWE:SPAC LIN	Select linear staircase sweep.
:SOUR2:VOLT 5	Detector 1 bias = 5V.
:SOUR3:VOLT 5	Detector 2 bias = 5V.
:OUTP1 ON	Turn on source outputs.
:READ?	Trigger sweep, request data.
:OUTP1 OFF	Turn off source outputs.

¹This command should normally be sent after START, STOP, and STEP to avoid delays caused by rebuilding sweep when each command is sent.

Custom sweep commands

Table 7-4 summarizes remote commands used for custom sweep operation. See Section 14, “Configure list,” for more details on these commands.

Table 7-4

Custom sweep commands

Command	Description
:SOURce[1]:CURRent:MODE LIST	Select current list (custom) sweep mode.
:SOURce[1]:LIST:CURRent < I-list>	Define I-source list (I1, I2,... In; 0 to 5.0, 100 max points).
:SOURce[1]:LIST:CURRent:APPend <I-list>	Add I-source list value(s) (I1, I2,...In; 0 to 5.0, 100 max).
:SOURce[1]:LIST:CURRent:POINts?	Query length of I-source list.
:SOURce[1]:LIST:DELay < D-list>	Define pulse delay (D1, D2,... Dn; 20e-6 to 0.5).*
:SOURce[1]:LIST:DELay:APPend <D-list>	Add pulse delay list value(s) (D1, D2,...Dn; 20e-6 to 0.5).*
:SOURce[1]:LIST:DELay:POINts?	Query length of pulse delay list.
:SOURce[1]:LIST:WIDTh < W-list>	Define pulse width list (W1, W2,... Wn; 500e-9 to 5e-3).*
:SOURce[1]:LIST:WIDTh:APPend <W-list>	Add pulse width list value(s) (W1, W2,...Wn; 500e-9 to 5e-3).*
:SOURce[1]:LIST:WIDTh:POINts?	Query length of pulse width list.
:SOURce[1]:LIST:DIRection <direction>	Set sweep direction (UP or DOWN).

*Settings affected by maximum duty cycle. See Section 5. If pulse delay and width are not programmed, default values of 1.5ms (delay) and 500ns (width) will be used and query will return 0.

Custom sweep programming example

As an example of custom sweep operation, assume a five-point sweep with the following sweep parameters:

- Current sweep mode: list (custom sweep).
- Sweep current points: 0.2A, 0.1A, 0.4A, 0.3A, 0.5A.
- Sweep delay points: 7ms, 4ms, 2ms, 8ms, 1ms.
- Sweep width points: 10 μ s, 50 μ s, 35 μ s, 20 μ s 60 μ s.

NOTE See Appendix H for a functional program example.

Table 7-5 summarizes the basic remote command sequence for performing the custom sweep described above.

Table 7-5

Custom sweep programming example

Command	Description
*RST :FORM:ELEM VOLT1,CURR2,CURR3 :SOUR1:CURR:MODE LIST :SOUR1:LIST:CURR 0.2, 0.1, 0.4, 0.3, 0.5 :SOUR1:LIST:DEL 7e-3, 4e-3, 2e-3, 8e-3, 1e-3 :SOUR1:LIST:WIDT 10e-6, 50e-6, 35e-6, 20e-6, 60e-6 :SOUR2:VOLT 5 :SOUR3:VOLT 5 :OUTP1 ON :READ? :OUTP1 OFF	Restore GPIB default conditions. Laser diode voltage, detector current data. Current list sweep mode. Set current sweep points. Set pulse delay sweep points. Set pulse width sweep points. Detector 1 bias = 5V. Detector 2 bias = 5V. Turn on source outputs. Trigger sweep, request data. Turn off source outputs.

8

Triggering

- **Trigger model** — Discusses the trigger model, including various layers, input triggers, and output trigger.
- **Trigger link** — Discusses the trigger link, including input triggers and output triggers.
- **Configuring triggering** — Details how to configure the various triggering aspects from the front panel.
- **Remote triggering** — Details the remote trigger model, summarizes trigger commands, and gives a basic triggering example.

Trigger model (front panel operation)

The flowchart in [Figure 8-1](#) summarizes triggering for front panel operation. The trigger model is modeled after the remote commands used to control triggering. Refer to “[Trigger model \(remote operation\)](#),” page 8-9. Key trigger model settings are included in the flowchart. Note that the BENCH defaults are denoted by the “+” symbol.

The trigger model consists of an Idle Layer and a Trigger Layer to provide versatility. A programmable counter allows operations to be repeated, and various input and output trigger options are available to provide synchronization between the Model 2520 and other instruments (via the Trigger Link).

Unless otherwise noted, the programmable aspects of the trigger model are performed from the CONFIGURE TRIGGER menu. See “[Configuring triggering](#),” page 8-7.

Figure 8-1
Trigger model (front panel operation)

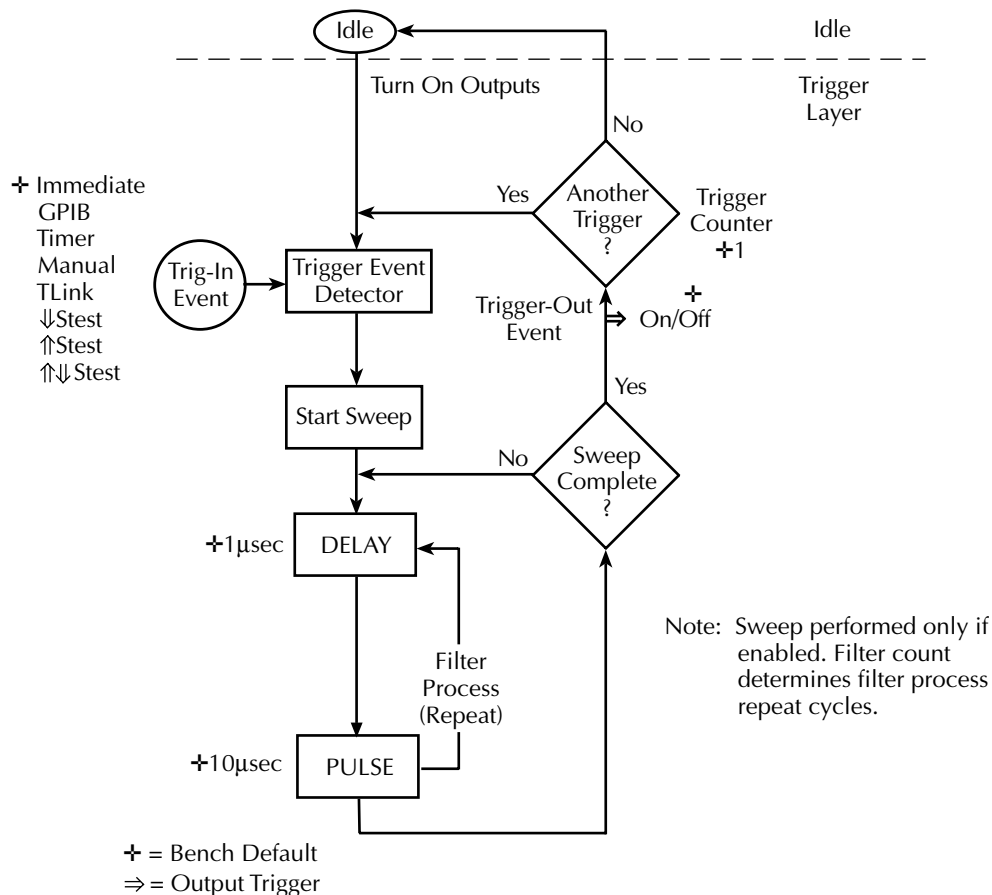

Idle layer

The Model 2520 is in the Idle Layer when it is not operating in the Trigger Layer of the trigger model. The Model 2520 can be returned to idle at any time by selecting the HALT menu item of the CONFIGURE TRIGGER menu. See [“Configuring triggering,” page 8-7](#).

Input triggers

The programmable trigger-in events for the Trigger Layer are described as follows:

IMMEDIATE — Event detection occurs immediately allowing operation to continue.

GPIB — Event detection occurs when a bus trigger (GET or *TRG) is received.

TIMER — With the Timer selected, event detection occurs immediately when the output is turned ON. On repeated passes via “Another Trigger? Yes”, event detection occurs when the programmed timer interval expires. If operation takes the “Another Trigger? No” route, the Timer resets allowing event detection to again occur immediately.

MANUAL — Event detection occurs when the TRIG key is pressed.

TLINK — Event detection occurs when an input trigger via the Trigger Link input line is received (see [“Trigger link,” page 8-5](#), for more information).

↓**STEST** — Event detection occurs when the start-of-test (SOT) line of the Digital I/O port is pulsed low. See [Section 9](#).

↑**STEST** — Event detection occurs when the SOT line of the Digital I/O port is pulsed high. See [Section 9](#).

↑↓**STEST** — Event detection occurs when the SOT line of the Digital I/O port is pulsed either high or low. See [Section 9](#).

Delay and pulse phases

The delay-pulse cycle consists of two phases: Delay and Pulse. (See [Section 5](#) for complete details.)

Delay phase

The programmable delay (set to between 20 μ s and 500ms with the DELAY key) is the time period between current pulses. Note, however, that the programmed delay is the minimum delay, and the actual delay depends on the pulse duty cycle (see [Section 5](#)).

Pulse phase

During the pulse phase, the unit outputs one current pulse with the programmed pulse width (set to between 500ns and 5ms with the PW key). If the unit is in the fixed (non-sweep mode), the pulse amplitude is the same for each cycle through the loop. However, if the unit is in the sweep mode, the pulse amplitude is set to the programmed value for that sweep point. 10MHz samples are taken during the pulse phase, and one set of voltage and current readings is DSP processed for each pulse.

Filtering

If the filter is enabled, the instrument cycles through the delay-pulse loop for the programmed filter count and averages the specified number of readings to yield a single set of filtered readings (measurements).

Sweep points

When a sweep is enabled, the unit cycles through the complete delay-pulse process (including filtering if enabled) for the programmed number of sweep points. For linear staircase sweeps, the number of points depends on the start, stop, and step current values. For log staircase sweeps, the number of points depends on the start and stop current values and the programmed number of points.

Counter

The programmable counter is used to repeat operations within the Trigger Layer. For example, to repeat a sweep three times, the trigger counter would be set to 3. If the sweep has a total of 10 points, a total of 30 measurements will be made.

The maximum finite trigger counter value is 5000. However, the product of the trigger count and the number of sweep points cannot exceed 5000.

Output trigger

The Model 2520 can be programmed to output a trigger (via rear panel Trigger Link connector) after various trigger model operations. An output trigger is used to trigger another instrument to perform an operation. See [“Trigger link,” page 8-5](#), for more information.

When enabled, the unit outputs a trigger when operation leaves the Trigger Layer and enters back into the Idle Layer. This output trigger is typically sent to another instrument to signal the end of a sweep.

Bench defaults

The bench defaults are listed as follows. They are also denoted in [Figure 8-1](#) by the “+” symbol.

- Trigger-In Event = Immediate
- Trigger Count = 1
- Timer = 0.1s
- Trigger Out Event = Off

Unless programmed otherwise, the Model 2520 will run in a continuous loop around the trigger model, processing one set of readings each time it goes through the loop.

Operation summary

The trigger model is designed to offer versatility for the various source and measure applications. It allows you to specify input and output triggers for both single-reading and sweep operation as follows:

- When sweeps are disabled, the unit will process one set of readings per Trigger-In Event and provide one output trigger per reading set. If the unit is in the Immediate trigger mode, it will process readings continuously.
- When a sweep is enabled, the unit will perform one sweep per Trigger-In Event. One output trigger will be generated when the sweep is completed.
- In order to use the RECALL mode, the unit must be placed in the INIT CONTINUOUS OFF mode. See “[Configuring triggering,](#)” page 8-7.

Trigger link

Input and output triggers are received and sent via the rear panel TRIGGER LINK connector. The trigger link has six lines. At the factory, line #2 is selected for output triggers, and line #1 is selected for input triggers. These input/output line assignments can be changed from the CONFIGURE TRIGGER menu. See “[Configuring triggering,](#)” page 8-7. The connector pinout is shown in [Figure 8-2](#).

Figure 8-2
Rear panel pinout

Rear Panel Pinout	Pin Number	Description
	1	Trigger Link 1
	2	Trigger Link 2
	3	Trigger Link 3
	4	Trigger Link 4
	5	Trigger Link 5
	6	Trigger Link 6
	7	Ground
	8	Ground

Input trigger requirements

An input trigger is used to satisfy event detection for a trigger model layer that is configured for the TRIGGER LINK event. See “[Trigger model \(front panel operation\)](#),” page 8-2. The input requires a falling-edge, TTL compatible pulse with the specifications shown in [Figure 8-3](#).

Figure 8-3
Trigger link input pulse specifications

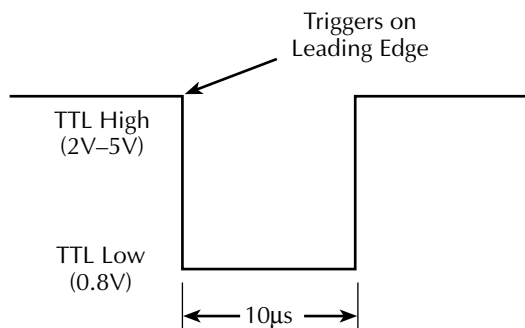

Output trigger specifications

The Model 2520 can be programmed to output a trigger after various trigger model actions. See “[Trigger model \(front panel operation\)](#),” page 8-2. The output trigger provides a TTL-compatible output pulse that can be used to trigger other instruments. The specifications for this trigger pulse are shown in [Figure 8-4](#). A trigger link line can source 1mA and sink up to 50mA.

Figure 8-4
Trigger link output pulse specifications

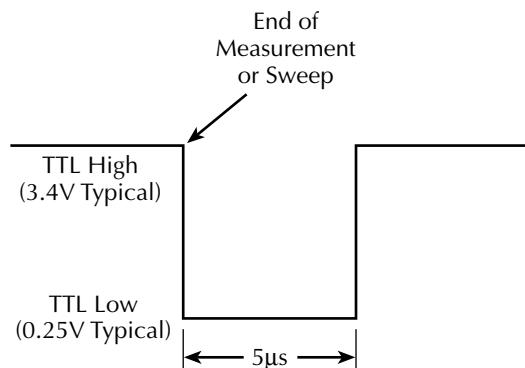

Configuring triggering

Triggering is configured from the CONFIGURE TRIGGER menu and is structured as follows.

NOTE See “*Trigger model (front panel operation)*,” page 8-2, for details on the following programmable aspects of triggering.

CONFIGURE TRIGGER menu

Press CONFIG and then TRIG to display the menu shown below and in [Figure 8-5](#). (Note that bullets indicate the primary items of the menu, while dashes and slashes indicate options. See [Section 1](#), “[Rules to navigate menus](#)” to check and/or change trigger options.)

- **COUNT** — Specify the arm count, FINITE (programmable count) or INFINITE (never ending count).
- **INIT** — Turns the INIT CONTINUOUS mode ON or OFF. For DC, non-sweep operation this mode is normally set to ON so that readings are processed continuously. For the RECALL mode, this mode must be set to OFF. OFF will automatically be selected if the PULSE mode is selected, or if a front panel sweep is initiated.
- **HALT** — Use to return the Model 2520 to the idle state. HALT does not turn off the output. The programmed source levels will still be available at the OUTPUT terminals. The following actions will take the Model 2520 out of idle:
 - Turn the outputs off and then on again.
 - Reselect the arm or trigger event.
 - Exit from the menu structure, and then re-enter it by pressing CONFIG and then TRIG.
- **TRIGGER-IN** — Use to select the detection event for the arm layer:
 - IMMEDIATE — Event detection occurs immediately.
 - GPIB — Event detection occurs when a bus trigger (GET or *TRG) is received.
 - TIMER — Initially, event detection is satisfied immediately. Subsequent event detection occurs after the timer interval elapses. After selecting this arm event, you will be prompted to specify the timer interval (in seconds).
 - MANUAL — Event detection occurs when the TRIG key is pressed.
 - TLINK — After selecting this arm event, you will be prompted to select the input line for the Trigger Link (#1 to #6).

- \downarrow STEST — Event detection occurs when the SOT line of the Digital I/O port is pulsed low (See Section 9).
- \uparrow STEST — Event detection occurs when the SOT line of the Digital I/O port is pulsed high.
- $\uparrow\downarrow$ STEST — Event detection occurs when the SOT line of the Digital I/O port is pulsed either high or low.
- **TRIGGER-OUT** — Use to configure the output trigger:
 - **LINE** — Select the Trigger Link line for the output trigger: line #1, #2, #3, #4, #5, or #6.
 - **EVENTS** — Enable (ON) or disable (OFF) the arm layer output triggers. TRIG-LAYER-DONE ON enables an output trigger on exiting the trigger layer.

Figure 8-5
Configure trigger menu tree

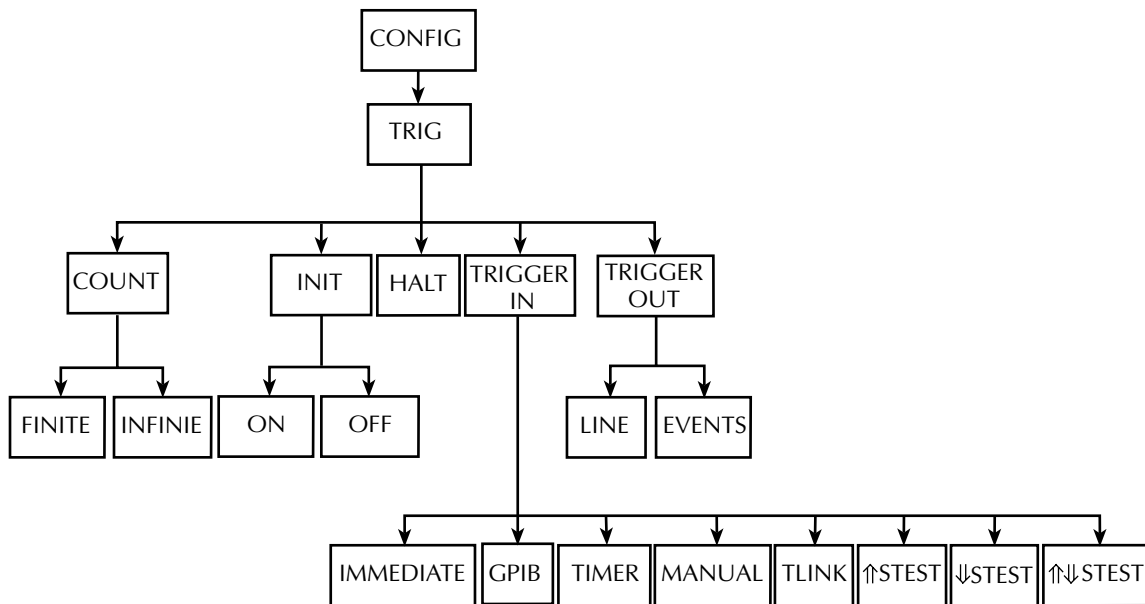

Remote triggering

Trigger model (remote operation)

The trigger model flowchart in [Figure 8-6](#) summarizes remote trigger operation. Operation is controlled by SCPI commands from the Trigger Subsystem. Key remote commands are included in the trigger model. Also note that the GPIB defaults are denoted by the “+” symbol.

The trigger model consists of two layers (Idle Layer and Trigger Layer) to provide versatility. A programmable counter allows operations to be repeated, and various input and output trigger options are available to provide synchronization between the Model 2520 and other instruments (via the Trigger Link).

Idle and initiate

The instrument is considered to be in the idle state when it is not operating within the trigger layer. While in the idle state, the instrument cannot perform any measurements. An initiate command is required to take the instrument out of idle. The following commands perform an initiate operation:

- :INITiate
- :READ?
- :MEASure?

Conversely, if the unit is taking readings, most commands (except DCL, SDC, IFC, and ABORt) are queued up and will not be executed until the unit returns to idle.

The :MEASure? command will automatically turn the output on. Note that after the instrument returns to the idle state, the output will remain on.

Figure 8-6
Trigger model (remote operation)

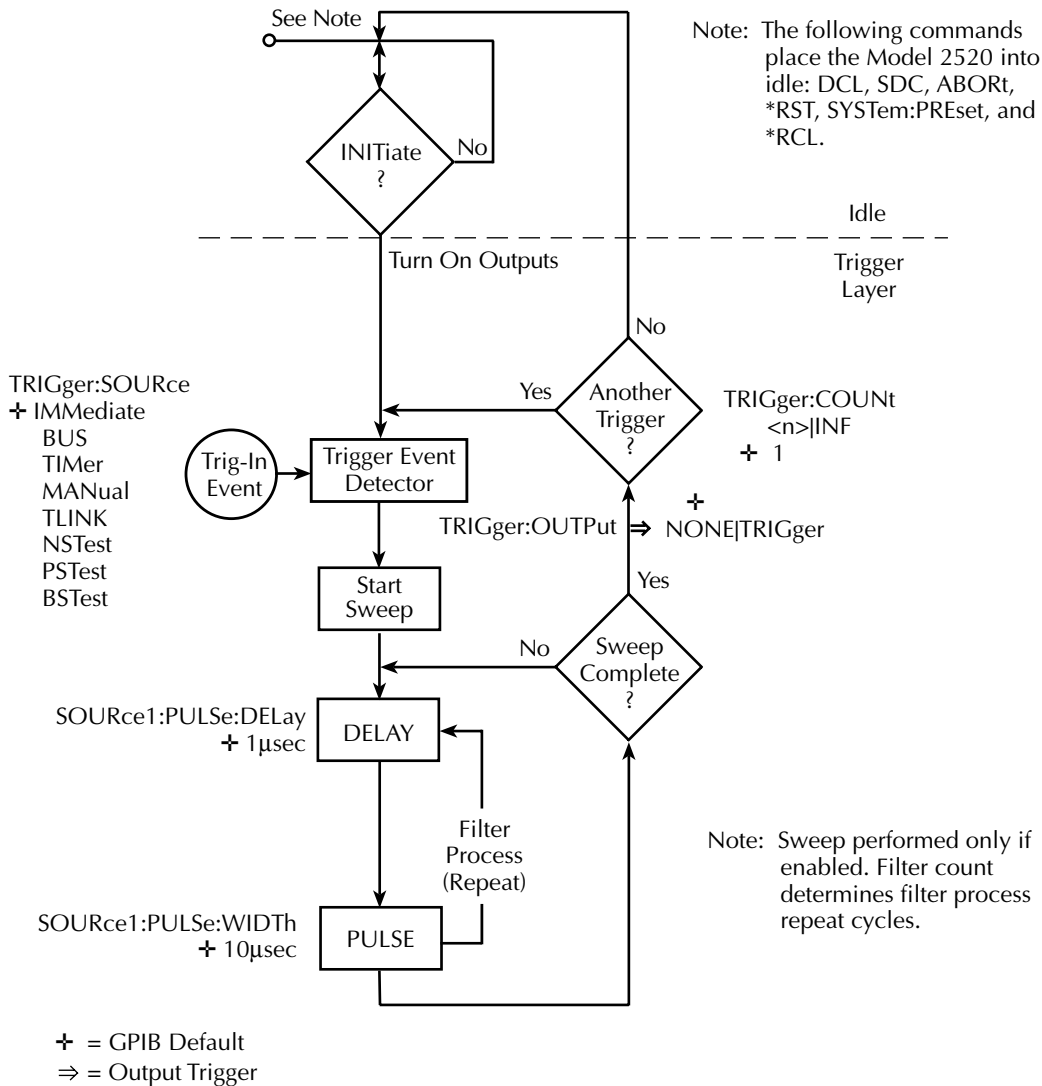

While operating within the trigger layer, most commands will not be executed until the Model 2520 completes all of its programmed source-measure operations and returns to the idle state. However, these commands will be processed while not in the idle state:

- :ABORt
- :SYSTem:PRESet
- *TRG or GET
- *RST
- *RCL
- SDC
- DCL
- IFC

NOTE SDC, DCL, or :ABORt place the Model 2520 in the idle state. For fastest response, use SDC or DCL to return to idle.

Event detection

Once the instrument is taken out of idle, operation proceeds through the trigger model to perform the measurement actions. In general, operation is held up at an event detector waiting for an input trigger until the programmed trigger event occurs.

Input triggers

The programmable trigger-in events for the Trigger Layer are described as follows:

IMMEDIATE — Event detection occurs immediately allowing operation to continue.

BUS — Event detection occurs when a bus trigger (GET or *TRG) is received.

TIMER — Event detection occurs immediately on the initial pass through the trigger model. Each subsequent detection is satisfied when the programmed timer interval elapses. The timer resets to its initial state when the instrument goes into idle.

MANUAL — Event detection occurs when the TRIG key is pressed. The Model 2520 must be in LOCAL mode for it to respond to the TRIG key. Press the LOCAL key or send GTL over the bus to take the Model 2520 out of remote.

TLINK — Event detection occurs when an input trigger via the Trigger Link input line is received (see “Trigger link,” page 8-5, for more information).

NSTest — Event detection occurs when the start-of-test (SOT) line of the Digital I/O port is pulsed low. See [Section 9](#).

PSTest — Event detection occurs when the start-of-test (SOT) line of the Digital I/O port is pulsed high. See [Section 9](#).

BSTest — Event detection occurs when the start-of-test (SOT) line of the Digital I/O port is pulsed either high or low. See [Section 9](#).

Delay and pulse phases

The delay-pulse cycle consists of two phases: Delay and Pulse. (See [Section 5](#) for details.)

Delay phase

The programmable delay is the time period between current pulses. The delay is set with the :DELAy commands and can be programmed in the range of 20 μ s to 500ms. Note, however, that the programmed delay is the minimum delay, and the actual delay depends on the pulse duty cycle (see [Section 5](#)).

Pulse phase

During the pulse phase, the unit outputs one current pulse with the programmed pulse width (set to between 500ns and 5ms with the :WIDTh commands). If the unit is in the fixed (non-sweep mode), the pulse amplitude is the same for each cycle through the loop. However, if the unit is in the sweep mode, the pulse amplitude is set to the programmed value for that sweep point. 10MHz samples are taken during the pulse phase, and one set of voltage and current readings is DSP processed for each pulse.

Filtering

If the filter is enabled, the instrument cycles through the delay-pulse loop for the programmed filter count and averages the specified number of readings to yield a single set of filtered readings (measurements).

Sweep points

When a sweep is enabled, the unit cycles through the complete delay-pulse process (including filtering if enabled) for the programmed number of sweep points. For linear staircase sweeps, the number of points depends on the start, stop, and step current values. For log staircase sweeps, the number of points depends on the start and stop current values and the programmed number of points. For custom sweeps, the number of points depends on the length of the sweep current list.

Counter

The programmable counter is used to repeat operations within the Trigger Layer. For example, to repeat a sweep three times, the trigger counter would be set to 3. If the sweep has a total of 10 points, a total of 30 measurements will be made.

The maximum finite trigger counter value is 5000. However, the product of the trigger count and the number of sweep points cannot exceed 5000.

Output trigger

As shown in [Figure 8-6](#), the Model 2520 can be programmed to output a trigger when operation leaves the Trigger Layer. This output trigger is typically sent to another instrument to signal the end of a sweep. The TRIG:OUTPut command is used to control this output trigger. The TRIGger parameter enables the trigger on exiting the Trigger Layer, and the NONE parameter disables the output trigger.

GPIB defaults

The GPIB defaults are listed as follows. They are also denoted in [Figure 8-6](#) by the “+” symbol.

- Trigger-In Source = Immediate
- Trigger Count = 1
- Timer = 0.1s
- Enabled output trigger = None

With outputs turned ON (OUTP1 ON), the Model 2520 will perform one measurement cycle when the INITiate command is sent. After the measurement, the Model 2520 returns to the idle state.

Operation summary

The trigger model is designed to offer versatility for the various source and measure applications. It allows you to specify input and output triggers for both single-reading and sweep operation as follows:

- When sweeps are disabled, the unit will process one set of readings per Trigger-In Event and provide one output trigger per reading. If the unit is in the Immediate trigger mode, it will process readings continuously.
- When a sweep is enabled, the unit will perform one sweep per Trigger-In Event. One output trigger will be generated when the sweep is completed.

Remote trigger commands

[Table 8-1](#) summarizes remote trigger commands. These commands are covered in more detail in [Section 14](#), “Trigger subsystem” except for *TRG, a common command covered in [Section 12](#).

Table 8-1
Remote trigger commands

Command	Description
:INITiate	Take Model 2520 out of idle state.
:ABORt	Reset trigger system.
:TRIGger:COUNt <count>	Set trigger count (1 to 5000).
:TRIGger:ILINe <line>	Select trigger link input line (1 to 6).
:TRIGger:OLINe <line>	Select trigger link output line (1 to 6).
:TRIGger:OUTPut <event>	Enable/disable output trigger. (TRIGger or NONE).
:TRIGger:SOURce <source>	Select trigger input source (IMMEDIATE, TIMER, BUS, TLINK, PSTest, NSTtest, or BSTest).
:TRIGger:TIMer <time>	Set trigger timer (0 to 99999.99s).
*TRG	Trigger Model 2520 (if BUS source selected).

Remote trigger example

Table 8-2 summarizes the command sequence for basic trigger operation. These commands set up Model 2520 triggering as follows:

- Trigger input source: bus
- Output trigger: enabled
- Trigger link output line: 1

After the unit is set up, :INIT is sent to take the unit out of idle. *TRG is sent to trigger the unit, after which it performs one measurement cycle.

Table 8-2
Remote triggering example

Command	Description
*RST	Restore GPIB defaults.
:SOUR1:CURR 0.1	Source 100mA.
:TRIG:SOUR BUS	Select bus trigger input source (*TRG command).
:TRIG:OUTP TRIG	Enable output trigger.
:TRIG:OLIN 1	Trigger link output line = #1.
:OUTP1 ON	Turn on source output.
:INIT	Take unit out of idle.
*TRG	Trigger reading.
:OUTP1 OFF	Turn off source output.
:FETC?	Request readings.

9 Digital I/O Port, Interlocks, and Pulse Sync Output

- **Digital I/O Port** — Discusses the various input/output lines on the Digital I/O Port as well as the +5V line that can be used to power external logic circuits.
- **Interlocks** — Describes how to use to determine the status of the interlocks.
- **Pulse sync output** — Describes the pulse sync output pulse that can be used to synchronize external equipment to current source pulses.

Digital I/O port

The Model 2520 has a digital input/output port that can be used to control external digital circuitry.

Port configuration

The Digital I/O Port is located on the rear panel and is shown in [Figure 9-1](#). Note that a standard male DB-9 connector is used for the Digital I/O port.

Figure 9-1
Digital I/O port

- 1 = Digital Output #1
- 2 = Digital Output #2
- 3 = Digital Output #3
- 4 = Digital Output #4
- 5 = Ground
- 6 = SOT (Start-of-Test) Input
- 7 = +5V
- 8 = Not Connected
- 9 = Ground

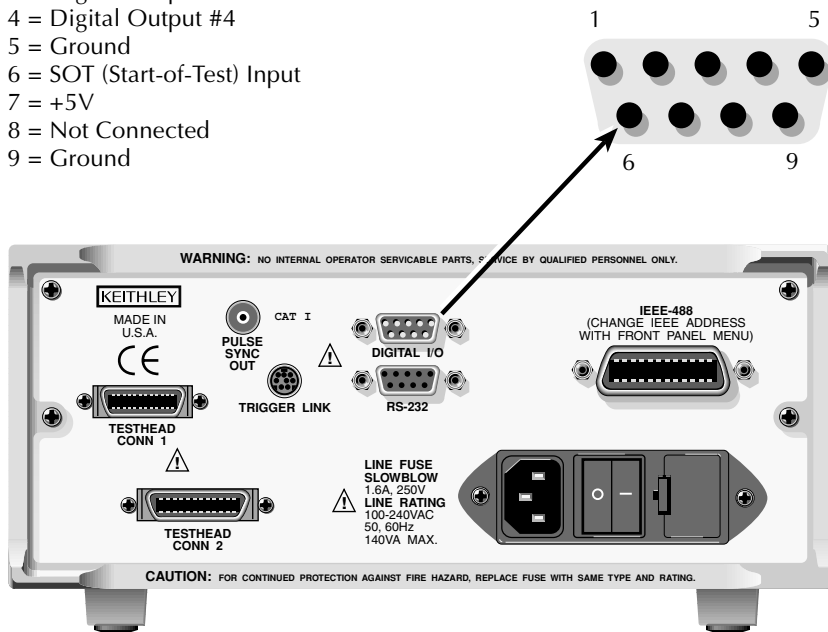

Digital output lines

The port provides four output lines and one input line. Each open-collector output can be set high (+5V) or low (0V). Each output line can source up to 2mA or sink up to 500mA.

Start-of-test (SOT) line

The input line (SOT) is a TTL-compatible logic line used by external equipment to start a test. With the \downarrow STEST trigger event selected, a low SOT pulse starts the testing process. With the \uparrow STEST trigger event selected, a high SOT pulse starts the testing process. With the $\uparrow\downarrow$ STEST trigger event selected, a high or low SOT pulse starts the testing process. See Section 8 for triggering information.

NOTE SOT input pulses are referenced to ground (pin 9).

+5V output

The Digital I/O Port provides a +5V output that can be used to drive external logic circuitry. Maximum current output for this line is 300mA. This line is protected by a self-resetting fuse.

Digital output configuration

There are two basic methods to connect external components to the digital output lines, sink operation and source operation.

Sink operation

Figure 9-2 shows the basic output configuration for sink operation. Note that the external relay coil is connected between the digital output line (pins 1 to 4) and +5V (pin 7). With this configuration, the digital output line must be set LO to energize the relay, and the maximum sink current is 500mA.

Figure 9-2
Sink operation

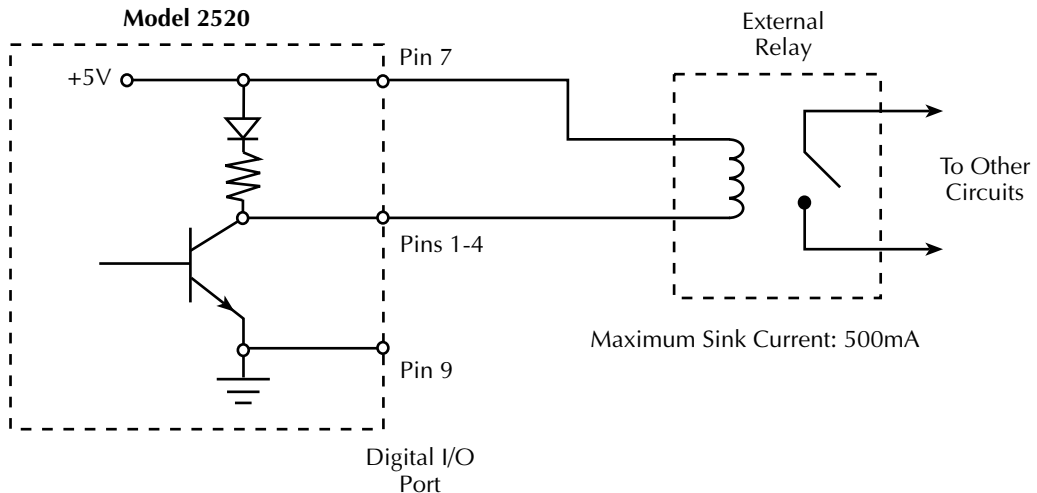

Source operation

Figure 9-3 shows the basic output configuration for source operation. In this case, the external relay coil is connected between the digital output line (pins 1 to 4) and ground (pin 9). With this configuration, the digital output line must be set HI to energize the relay, and the maximum source current is 2mA.

Figure 9-3
Source operation

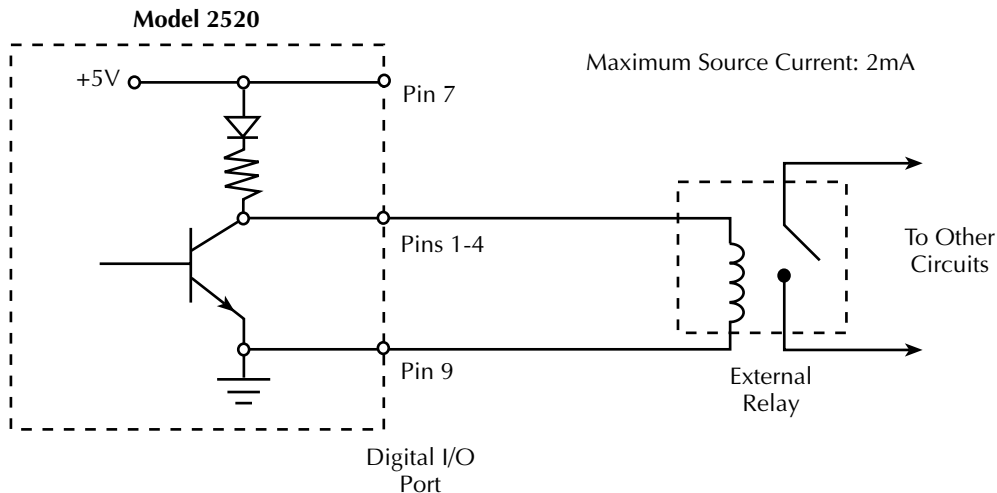

Controlling digital output lines

The Digital I/O lines can be used to control external relays or indicator lights. You can control these lines either from the front panel or via remote as covered below.

Front panel digital output control

Set digital output line logic levels from the front panel as follows:

1. Press the DIG OUT key.
2. Using the EDIT keys, set the digital output parameter to the desired decimal value (Table 9-1). For example, to set the output lines to L, H, H, H, set the digital output parameter value to 7.
3. Press EXIT to return to normal display.

Remote digital output control

Use the :SOURce4:TTL <NRf> command to control the digital output line logic levels, where <NRf> is the decimal value shown in [Table 9-1](#). For example, send the following command to set the output lines to L, H, L, H:

```
:SOUR4:TTL 5
```

Table 9-1

Digital output line settings

OUT 4	OUT 3	OUT 2	OUT 1	Decimal value
L	L	L	L	0
L	L	L	H	1
L	L	H	L	2
L	L	H	H	3
L	H	L	L	4
L	H	L	H	5
L	H	H	L	6
L	H	H	H	7
H	L	L	L	8
H	L	L	H	9
H	L	H	L	10
H	L	H	H	11
H	H	L	L	12
H	H	L	H	13
H	H	H	L	14
H	H	H	H	15

L = Low (Gnd)

H = High (>+3V)

Interlocks

The Model 2520 testhead is equipped with two interlock protection devices. The REMOTE INTERLOCK connector is a DB-9 connector intended for such applications as a remote interlock switch, while the KEY INTERLOCK connector is intended for connections for a security key switch.

NOTE Both interlocks must be enabled for operation. Otherwise the source outputs will not turn on.

See [Section 2](#) for detailed interlock connection information.

Interlock operation

Figure 9-4 shows typical connections to the REMOTE INTERLOCK connector. If the fixture switch is closed (Figure 9-4A), the three source outputs are enabled and can be turned on. If the lid of the test fixture opens (Figure 9-4B), the switch opens, and the three source outputs are disabled and cannot be turned on.

Figure 9-4
Interlock operation

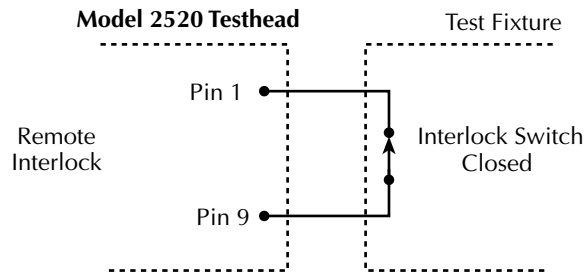

A. Model 2520 outputs can be turned on.

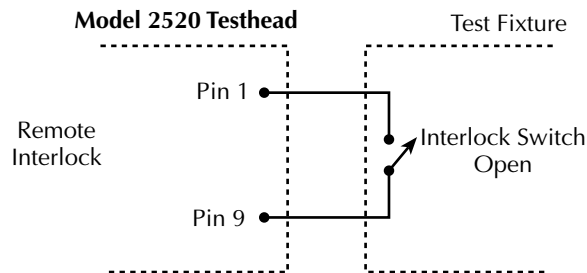

B. Model 2520 outputs cannot be turned on.

Interlock status indicator test sequence

Perform the following steps to verify the operation of the indicator lights:

1. Remove any connections from the testhead CURRENT OUTPUT, VOLTAGE SENSE, or DETECTOR terminals.
2. Connect the testhead to the mainframe, and follow the steps for power connection and power-up sequence in [Section 1](#).
3. Bypass the interlock switch on the remote testhead with a bypass plug or cable, connected as shown in [Figure 9-4A](#).
4. Insert the key provided into the key interlock, and verify it is in the DISABLED position.

At this point the INTERLOCK STATUS indicator should be BLUE, and the LASER POWER ON indicator should be OFF on the testhead. The OUTPUT ON/OFF indicator on the mainframe should be OFF.

5. Turn the key in the key interlock to ENABLED.
At this point the INTERLOCK STATUS indicator should be GREEN, and the LASER POWER ON indicator should be OFF on the testhead. The OUTPUT ON/OFF indicator on the mainframe should be OFF.
6. Press the OUTPUT ON/OFF switch on the mainframe.
At this point the INTERLOCK STATUS indicator should be GREEN, and the LASER POWER ON indicator should be BLUE on the testhead. The OUTPUT ON/OFF indicator on the mainframe should be BLUE.
7. Turn the key in the key interlock to DISABLED.
At this point the INTERLOCK STATUS indicator should be BLUE, and the LASER POWER ON indicator should be OFF on the testhead. The OUTPUT ON/OFF indicator on the mainframe should be OFF.

WARNING If at any time the indicators provided on the testhead, for INTERLOCK STATUS or LASER POWER ON, should fail to light or to properly indicate status, immediately contact a Keithley service representative for repair. Failure to do so may expose the user to hazards without proper warnings.

Reading interlock state

To read the state of the interlocks, send this query via remote:

```
:OUTP1:INT:TRIP?
```

The response to this query is either 0 or 1 as follows:

- A returned value of 1 indicates that at least one of the interlocks is tripped (circuit open), and the outputs cannot be turned on.
- A returned value of 0 indicates neither interlock is tripped (circuit closed), and the outputs can be turned on.

Pulse sync output

The Model 2520 has a pulse sync output that allows synchronization of external equipment to the laser diode current source pulse.

Pulse sync waveform

Figure 9-5 shows the pulse sync waveform, which is a 5V pulse with 50 Ω output impedance. The pulse timing and duration are approximately the same as those for the laser diode current source pulse; however, there is a certain amount of latency between the pulse sync and the laser diode current pulse.

Figure 9-5

Pulse sync output waveform

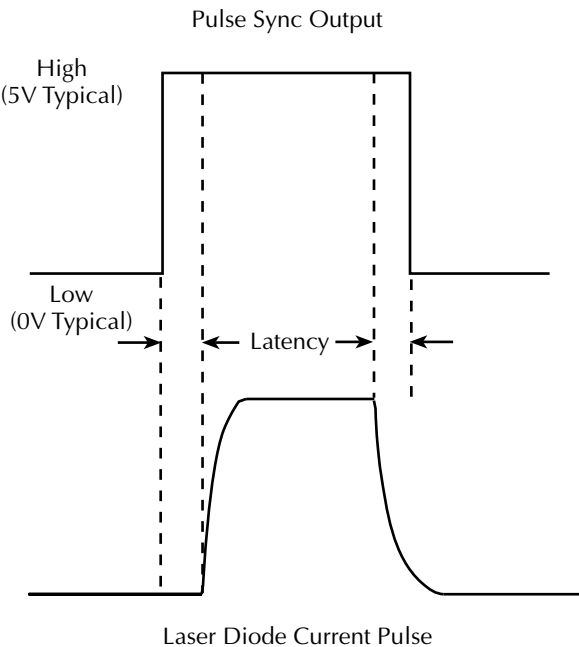

Pulse sync connections

Figure 9-6 shows typical pulse sync connections. Use quality BNC 50Ω RG-58 cable to avoid pulse distortion that could cause timing and jitter problems.

Figure 9-6
Pulse sync out connections

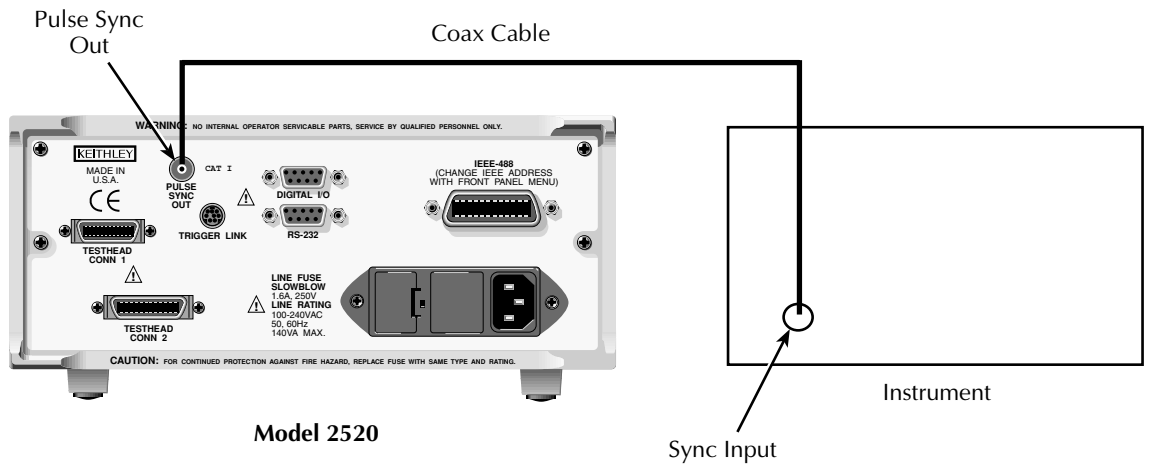

10

Remote Operations

- **Differences: remote vs. local operation** — Summarizes remote operation enhancements and local-to-remote and remote-to-local transitions.
- **Selecting an interface** — Describes how to select between the GPIB and RS-232 interfaces.
- **GPIB operation** — Covers GPIB bus standards, bus connections, and primary address selection.
- **General bus commands** — Describes general bus commands used for fundamental GPIB control.
- **Front panel GPIB operation** — Summarizes GPIB error messages, status indicators, and using the LOCAL key.
- **Programming syntax** — Describes the basic programming syntax for both common and SCPI commands.
- **RS-232 interface operation** — Outlines use of the RS-232 interface to control the Model 2520 via remote.

Differences: remote vs. local operation

Local-to-remote transition

When changing from local to remote operation, the following takes place:

- The Model 2520 stops taking readings and is placed into the Idle layer of the Trigger Model.
- All menus are exited.
- All pending front panel commands are aborted.
- The reading buffer is cleared (i.e. FETCh?, CALC1:DATA?, CALC3:DATA?, CALC3:DATA?, and CALC4:DATA? will not return any data until the Model 2520 takes readings while in remote.)
- All other settings remain unaffected.
- The laser diode current source is placed in the FIXEd mode.

Remote-to-local transition

When changing from remote to local operation, the following takes place:

- If the laser diode current source is in the DC mode and the output is turned on, the continuous init mode is turned on. Otherwise, the Model 2520 is placed into the Idle layer of the Trigger Model.
- All user-defined displays are disabled.
- The display is re-enabled if it was previously turned off.
- The laser diode current source is placed in the FIXEd mode.

Selecting an interface

The Model 2520 supports two built-in remote interfaces:

- GPIB (General Purpose Interface Bus)
- RS-232 interface

You can use only one interface at a time. The factory default interface selection is the GPIB bus. You can select the interface only from the front panel. The interface selection is stored in non-volatile memory; it does not change when power has been off or after a remote interface reset.

The GPIB bus is the IEEE-488 interface. You must select a unique address for the Model 2520. The address is displayed when the instrument is turned on. At the factory, the address is set to 25. The IEEE-488 address can only be changed from the front panel while the IEEE-488 bus is enabled.

The RS-232 interface is a serial interface. Programmable aspects of this interface include the following (factory default settings are shown in parentheses):

- Baud rate (9600)
- Data bits (8)
- Parity (none)
- Terminator (CR)
- Flow control (none)

RS-232 settings for baud rate, Parity, and data bits are accessible only from the front panel while RS-232 is enabled.

An interface is selected and configured from the COMMUNICATIONS SETUP menu accessed with the COMM key. For details on the programmable aspects of the interfaces, see “Primary address,” page 10-6, and “RS-232 interface operation,” page 10-16.

NOTE When changing interface selections, the Model 2520 performs a power-on reset. To check and/or change options of the selected interface, you must re-enter the COMM menu.

GPIB operation

This section contains information about GPIB standards, bus connections, and primary address selection.

GPIB standards

The GPIB is the IEEE-488 instrumentation data bus with hardware and programming standards originally adopted by the IEEE (Institute of Electrical and Electronic Engineers) in 1975. The Model 2520 conforms to these standards:

- IEEE-488.1-1987
- IEEE-488.2-1992

The above standards define a syntax for sending data to and from instruments, how an instrument interprets this data, what registers should exist to record the state of the instrument, and a group of common commands. The Model 2520 also conforms to this standard:

- SCPI 1996.0 (Standard Commands for Programmable Instruments)

This standard defines a command language protocol. It goes one step farther than IEEE-488.2-1992 and defines a standard set of commands to control every programmable aspect of an instrument.

GPIB connections

To connect the Model 2520 to the GPIB bus, use a cable equipped with standard IEEE-488 connectors as shown in [Figure 10-1](#).

Figure 10-1
IEEE-488 connector

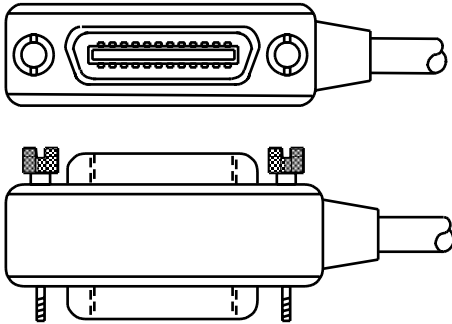

To allow many parallel connections to one instrument, stack the connectors. Two screws are located on each connector to ensure that connections remain secure. [Figure 10-2](#) shows a typical connecting scheme for a multi-unit test system.

Figure 10-2
IEEE-488 multi-unit test system connections

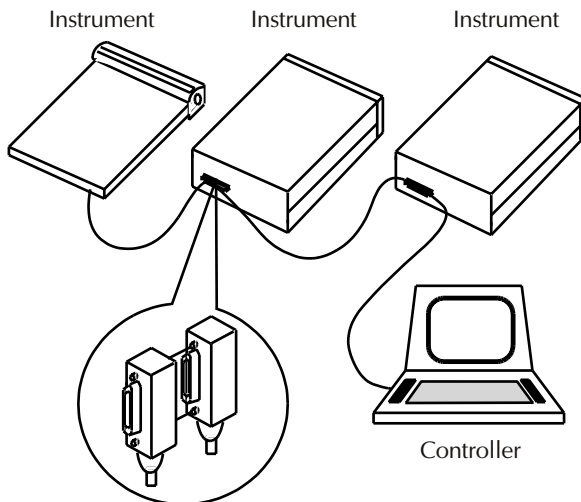

To avoid possible mechanical damage, stack no more than three connectors on any one unit.

NOTE To minimize interference caused by electromagnetic radiation, use only shielded IEEE-488 cables. Available shielded cables from Keithley are Models 7007-1 and 7007-2.

To connect the Model 2520 to the IEEE-488 bus, follow these steps:

1. Line up the cable connector with the connector located on the rear panel. The connector is designed so it will fit only one way. Figure 10-3 shows the location of the IEEE-488 connector.
2. Tighten the screws securely, making sure not to overtighten them.

Figure 10-3
IEEE-488 and RS-232 connector location

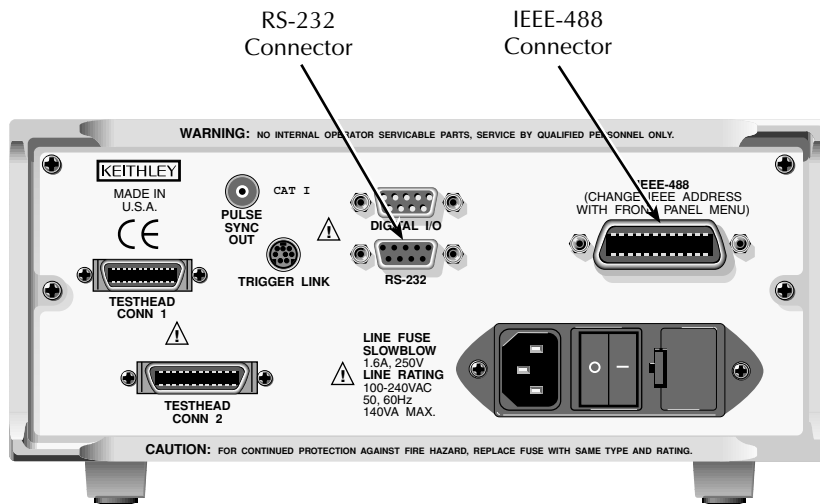

Model 2520

3. Connect any additional connectors from other instruments as required for your application.
4. Make sure the other end of the cable is properly connected to the controller. Most controllers are equipped with an IEEE-488 style connector, but a few may require a different type of connecting cable. See your controller's instruction manual for information about properly connecting to the IEEE-488 bus.

NOTE You can only have 15 devices connected to an IEEE-488 bus, including the controller. The maximum cable length is either 20 meters or two meters multiplied by the number of devices, whichever is less. Not observing these limits may cause erratic bus operation.

Primary address

The Model 2520 ships from the factory with a GPIB primary address of 25. When the unit powers up, it momentarily displays the primary address. You can set the address to a value from 0 to 30, but do not assign the same address to another device or to a controller that is on the same GPIB bus (controller addresses are usually 0 or 21).

The primary address can be checked and/or changed from the COMMUNICATIONS SETUP menu accessed with the COMM key. This menu option also allows you to select the 488.1 or SCPI protocol ([Appendix G](#)).

To set the primary address:

1. Press the COMM key.
2. Select GPIB, then press ENTER.
3. Use the EDIT keys to set the primary address to the desired value, then press ENTER.
4. Select GPIB or 488.1 protocol, then press ENTER. (See [Appendix G](#) for details.)
5. Press EXIT to return to normal display.

General bus commands

General commands are those commands, such as DCL, that have the same general meaning regardless of the instrument. [Table 10-1](#) lists the general bus commands.

Table 10-1

General bus commands

Command	Effect on Model 2520
REN	Goes into remote when next addressed to listen.
IFC	Goes into talker and listener idle states.
LLO	LOCAL key locked out.
GTL	Cancel remote; restore Model 2520 front panel operation.
DCL	Returns all devices to known conditions.
SDC	Returns Model 2520 to known conditions.
GET	Initiates a trigger.
SPE, SPD	Serial polls the Model 2520.

REN (remote enable)

The remote enable command is sent to the Model 2520 by the controller to set up the instrument for remote operation. Generally, the instrument should be placed in the remote mode before you attempt to program it over the bus. Setting REN true does not place the instrument in the remote state. You must address the instrument to listen after setting REN true before it goes into remote.

The Model 2520 must be in remote in order to use the following commands to trigger and acquire readings:

- :INITiate and then :FETCh?
- :READ?
- :MEASure?

IFC (interface clear)

The IFC command is sent by the controller to place the Model 2520 in the local, talker, listener idle states. The unit responds to the IFC command by cancelling front panel TALK or LSTN lights if the instrument was previously placed in one of these states.

Note that this command does not affect the status of the instrument. Settings, data, and event registers are not changed.

To send the IFC command, the controller need only set the IFC line true for a minimum of 100 μ s.

LLO (local lockout)

Use the LLO command to prevent local operation of the instrument. After the unit receives LLO, all of its front panel controls except OUTPUT OFF are inoperative. In this state, pressing LOCAL will not restore control to the front panel. The GTL command restores control to the front panel. Cycling power will also cancel local lockout.

GTL (go to local)

Use the GTL command to put a remote-mode instrument into local mode. The GTL command also restores front panel key operation.

DCL (device clear)

Use the DCL command to clear the GPIB interface and return it to a known state. Note that the DCL command is not an addressed command, so all instruments equipped to implement DCL will do so simultaneously.

When the Model 2520 receives a DCL command, it clears the Input Buffer and Output Queue, cancels deferred commands, and clears any command that prevents the processing of any other device command. A DCL does not affect instrument settings and stored data.

SDC (selective device clear)

The SDC command is an addressed command that performs essentially the same function as the DCL command. However, since each device must be individually addressed, the SDC command provides a method to clear only selected instruments instead of clearing all instruments simultaneously, as is the case with DCL.

GET (group execute trigger)

GET is a GPIB trigger that is used as a trigger event to control operation. The Model 2520 reacts to this trigger if it is the programmed trigger control source. The following command selects the GPIB trigger control source:

```
:TRIG:SOURce BUS
```

NOTE With `:TRIG:SOURce BUS` selected and an `:INITiate` command sent, do not send any commands (except `GET`, `DCL`, `SDC`, `IFC`, `*TRG`, and `:ABORT`) while performing source and measure operations (ARM annunciator on). If you do, erratic operation will occur.

SPE, SPD (serial polling)

Use the serial polling sequence to obtain the Model 2520 serial poll byte. The serial poll byte contains important information about internal functions. See [Section 11](#). Generally, the serial polling sequence is used by the controller to determine which of several instruments has requested service with the SRQ line. However, the serial polling sequence may be performed at any time to obtain the status byte from the Model 2520.

Front panel GPIB operation

This section describes aspects of the front panel that are part of GPIB operation, including messages, status indicators, and the LOCAL key.

Error and status messages

See [Appendix B](#) for a list of status and error messages associated with IEEE-488 programming. The instrument can be programmed to generate an SRQ, and command queries can be performed to check for specific error conditions.

GPIB status indicators

The REM (remote), TALK (talk), LSTN (listen), and SRQ (service request) annunciators show the GPIB bus status. Each of these indicators is described below.

REM

This indicator shows when the instrument is in the remote state. REM does not necessarily indicate the state of the bus REN line, as the instrument must be addressed to listen with REN true before the REM indicator turns on. When the instrument is in remote, all front panel keys, except for the LOCAL key, are locked out. When REM is turned off, the instrument is in the local state, and front panel operation is restored.

NOTE If LLO is in effect, LOCAL will be locked out. OUTPUT ON/OFF is still operational in remote. If TRIG:SOUR is set to manual, the TRIG key will be active in remote.

TALK

This indicator is on when the instrument is in the talker active state. Place the unit in the talk state by addressing it to talk with the correct MTA (My Talk Address) command. TALK is off when the unit is in the talker idle state. Place the unit in the talker idle state by sending a UNT (Untalk) command, addressing it to listen, or sending the IFC (Interface Clear) command.

LSTN

This indicator is on when the Model 2520 is in the listener active state, which is activated by addressing the instrument to listen with the correct MLA (My Listen Address) command. LSTN is off when the unit is in the listener idle state. Place the unit in the listener idle state by sending UNL (Unlisten), addressing it to talk, or sending IFC (Interface Clear) command over the bus.

SRQ

You can program the instrument to generate a service request (SRQ) when one or more errors or conditions occur. When this indicator is on, a service request has been generated. This indicator stays on until the serial poll byte is read or all the conditions that caused SRQ have been cleared. See [Section 11](#) for more information.

LOCAL key

The LOCAL key cancels the remote state and restores local operation of the instrument.

Pressing the LOCAL key also turns off the REM indicator and returns the display to normal if a user-defined message was displayed.

If the LLO (Local Lockout) command is in effect, the LOCAL key is also inoperative.

For safety reasons, the OUTPUT key can be used to turn the output off while in LLO.

Programming syntax

The information in this section covers syntax for both common commands and SCPI commands. For information not covered here, see the IEEE-488.2 and SCPI standards. See [Section 12](#) and [Section 14](#) for more details on common and SCPI commands, respectively.

Command words

Program messages are made up of one or more command words.

Commands and command parameters

Common commands and SCPI commands may or may not use a parameter. The following are some examples:

*SAV <NRf>	Parameter (NRf) required
*RST	No parameter used
:CALCulate1:STATe 	Parameter required
:SYSTem:PRESet	No parameter used

NOTE At least one space between the command word and the parameter is required.

Brackets [] — Some command words are enclosed in brackets ([]). These brackets are used to denote an optional command word that does not need to be included in the program message. For example:

```
:INITiate[:IMMediate]
```

These brackets indicate that :IMMediate is implied (optional) and does not have to be used. Thus, the above command can be sent in one of two ways:

```
:INITiate
```

or

```
:INITiate:IMMediate
```

Notice that the optional command is used without the brackets. When using optional command words in your program, do not include the brackets.

Parameter types — The following are some of the more common parameter types:

	Boolean — Used to enable or disable an instrument operation. 0 or OFF disables the operation, and 1 or ON enables the operation. Example: :CALCulate1:STATe ON Enable Calc 1 math
<name>	Name parameter — Select a parameter name from a listed group.

Example:

```
<name> = NONE
:TRIGger:OUTPut NONE
```

<NRf> **Numeric representation format** — This parameter is a number that can be expressed as an integer (e.g., 8), a real number (e.g., 23.6), or an exponent (2.3E6). Example:

```
:SOURce1:VOLTage:PROTection 5 Sets protection to 5V.
```

<n> **Numeric value** — A numeric value parameter can consist of an NRf number or one of the following name parameters: DEFault, MINimum, MAXimum. When the DEFault parameter is used, the instrument is programmed to the *RST default value. When the MINimum parameter is used, the instrument is programmed to the lowest allowable value. When the MAXimum parameter is used, the instrument is programmed to the largest allowable value. Examples:

```
:SOURce1:PULSe:DELAy 0.05 Sets pulse delay to 50ms.
```

```
:SOURce1:PULSe:DELAy DEFault Sets pulse delay to 10ms.
```

```
:SOURce1:PULSe:DELAy MINimum Sets pulse delay to 20µs.
```

```
:SOURce1:PULSe:DELAy MAXimum Sets pulse delay to 100msec.
```

<numlist> **Numlist** — Specify one or more numbers for a list. Example:

```
:STATus:QUEue:ENABLe (-110:-222) Enable errors -110
through -222
```

<NDN> **Non-decimal numeric** — This parameter is used to send values in the binary, octal, or hexadecimal format. The prefix designates the format type:

#Bxx...x #B specifies the binary format.

xx...x is the binary number (using 0s and 1s).

#Qxx...x #Q specifies the octal format.

xx...x is the octal number (values 0 through 7).

#Hxx...x #H specifies the hexadecimal format.

xx...x is the hexadecimal number (values 0 through 9 and A through F).

Examples to send the decimal value 36 in the non-decimal formats:

```
*ESE #b100100 Binary format
```

```
*ESE #q44 Octal format
```

```
*ESE #h24 Hexadecimal format
```

Angle brackets < > — Angle brackets (< >) are used to denote a parameter type. Do not include the brackets in the program message. For example:

```
:OUTPut1 <b>
```

The indicates a Boolean-type parameter is required. Therefore, to enable the selected source, you must send the command with the ON or 1 parameter as follows:

```
:OUTPut1 ON
```

```
:OUTPut1 1
```

Query commands

This type of command requests (queries) the presently programmed status. It is identified by the question mark (?) at the end of the fundamental form of the command. Most commands have a query form:

:SOURce1:PULSe:DELay? Queries the pulse delay.

Most commands that require a numeric parameter (<n>) can also use the DEFault, MINimum, and MAXimum parameters for the query form. These query forms are used to determine the *RST default value and the upper and lower limits for the fundamental command. Examples are:

:SOURce1:PULSe:DELay? DEFault Queries the *RST default value.

:SOURce1:PULSe:DELay? MINimum Queries the lowest allowable value.

:SOURce1:PULSe:DELay? MAXimum Queries the largest allowable value.

Case sensitivity

Common commands and SCPI commands are not case sensitive. You can use upper or lower case and any case combination. Examples:

*RST = *rst

:DATA? = :data?

:SYSTem:PRESet = :system:preset

NOTE Using all upper case will result in slightly faster command response times.

Long-form and short-form versions

A SCPI command word can be sent in its long-form or short-form version. The command subsystem tables in [Section 14](#) provide the long-form version. However, the short-form version is indicated by upper case characters. Examples:

:SYSTem:PRESet long-form

:SYST:PRES short-form

:SYSTem:PRES long-form and short-form combination

Note that each command word must be in long-form or short-form, and not something in between. For example, :SYSTe:PRESe is illegal and will generate an error. The command will not be executed.

Short-form rules

Use the following rules to determine the short-form version of any SCPI command:

- If the length of the command word is four letters or less, no short form version exists. Example:
- :feed = :feed

These rules apply to command words that exceed four letters:

- If the fourth letter of the command word is a vowel (including “y”), delete it and all the letters after it. Example:
- :immediate = :imm
- If the fourth letter of the command word is a consonant, retain it but drop all the letters after it. Example:
- :format = :form
- If the command contains a question mark (; query) or a non-optional number included in the command word, you must include it in the short-form version. Example:
- :delay? = :del?
- Command words or characters that are enclosed in brackets ([]) are optional and need not be included in the program message.

NOTE For fastest response to commands, always use short forms.

Program messages

A program message is made up of one or more command words sent by the computer to the instrument. Each common command is a three letter acronym preceded by an asterisk (*). SCPI commands are categorized in the :STATus subsystem and are used to explain how command words are structured to formulate program messages.

:STATus	Path (Root)
:OPERation	Path
:ENABle <NRf>	Command and parameter
:ENABle?	Query command
:PRESet	Command

Single command messages

The above command structure has three levels. The first level is made up of the root command (:STATus) and serves as a path. The second level is made up of another path (:OPERation) and a command (:PRESet). The third path is made up of one command for the :OPERation path. The three commands in this structure can be executed by sending three separate program messages as follows:

```
:stat:oper:enab <NRf>
```

```
:stat:oper:enab?
```

```
:stat:pres
```

In each of the above program messages, the path pointer starts at the root command (:stat) and moves down the command levels until the command is executed.

Multiple command messages

You can send multiple command messages in the same program message as long as they are separated by semicolons (;). The following is an example showing two commands in one program message:

```
:stat:oper; :stat:oper:enab <NRf>
```

When the above is sent, the first command word is recognized as the root command (:stat). When the next colon is detected, the path pointer moves down to the next command level and executes the command. When the path pointer sees the colon after the semicolon (;), it resets to the root level and starts over.

Commands that are on the same command level can be executed without having to retype the entire command path. Example:

```
:stat:oper:enab <NRf>; enab?
```

After the first command (:enab) is executed, the path pointer is at the third command level in the structure. Since :enab? is also on the third level, it can be typed in without repeating the entire path name. Notice that the leading colon for :enab? is not included in the program message. If a colon were included, the path pointer would reset to the root level and expect a root command. Since :enab? is not a root command, an error would occur.

Command path rules

- Each new program message must begin with the root command, unless it is optional (e.g., [:SENSe[1]]). If the root is optional, simply treat a command word on the next level as the root. For fastest operation, do not send optional data.
- The colon (:) at the beginning of a program message is optional and need not be used. Note that eliminating the first colon will result in fastest operation. Example:
 - :stat:pres = stat:pres
- When the path pointer detects a colon (:) it moves down to the next command level. An exception is when the path pointer detects a semicolon (;), which is used to separate commands within the program message (see next rule).
- When the path pointer detects a colon (:) that immediately follows a semicolon (;), it resets to the root level.
- The path pointer can only move down. It cannot be moved up a level. Executing a command at a higher level requires that you start over at the root command.

Using common and SCPI commands in the same message

Both common commands and SCPI commands can be used in the same message as long as they are separated by semicolons (;). A common command can be executed at any command level and will not affect the path pointer. Example:

```
:stat:oper:enab <NRf>; *ESE <NRf>
```

Program message terminator (PMT)

Each program message must be terminated with an LF (line feed), EOI (end or identify), or an LF+EOI. The bus will hang if your computer does not provide this termination. The following example shows how a multiple command program message must be terminated:

```
:outp1 on <PMT>
```

Command execution rules

- Commands execute in the order that they are presented in the program message.
- An invalid command generates an error and, of course, is not executed.
- Valid commands that precede an invalid command in a multiple command program message are executed.
- Valid commands that follow an invalid command in a multiple command program message are ignored.

Response messages

A response message is the message sent by the instrument to the computer in response to a query command program message.

Sending a response message

After sending a query command, the response message is placed in the Output Queue. When the Model 2520 is then addressed to talk, the response message is sent from the Output Queue to the computer.

Multiple response messages

If you send more than one query command in the same program message (*Multiple command messages*), the multiple response messages for all the queries are sent to the computer when the Model 2520 is addressed to talk. The responses are sent in the order the query commands were sent and are separated by semicolons (;). Items within the same query are separated by commas (.). The following example shows the response message for a program message that contains four single item query commands:

```
0; 1; 1; 0
```

Response message terminator (RMT)

Each response is terminated with an LF (Line Feed) and EOI (end or identify). The following example shows how a multiple response message is terminated:

```
0; 1; 1; 0 <RMT>
```

Message exchange protocol

Two rules summarize the message exchange protocol:

Rule 1. You must always tell the Model 2520 what to send to the computer.

The following two steps must always be performed to send information from the instrument to the computer:

1. Send the appropriate query command(s) in a program message.
2. Address the Model 2520 to talk.

Rule 2. The complete response message must be received by the computer before another program message can be sent to the Model 2520.

RS-232 interface operation

NOTE The programmable aspects of RS-232 operation (baud rate, data bits, parity, and terminator) are configured from the COMMUNICATIONS SETUP menu accessed with the COMM key.

Sending and receiving data

The RS-232 interface transfers data using 8 data bits, 1 stop bit, and no parity. Make sure the device you connect to the Model 2520 also uses these settings.

You can break data transmissions by sending a ^C (decimal 3) or ^X (decimal 18) character string to the instrument, or by sending an RS-232 break condition (holding the transmit line low for >11 bits). This clears any pending operation, discards any pending output, and returns a "DCL."

Baud rate

The baud rate is the rate at which the Model 2520 and the programming terminal communicate. Choose one these available rates:

- 57600
- 38400
- 19200

- 9600
- 4800
- 2400
- 1200
- 600
- 300

The factory selected baud rate is 9600.

When you choose a baud rate, make sure the programming terminal or printer that you are connecting to the Model 2520 can support the baud rate you selected. Both the Model 2520 and the other device must be configured for the same baud rate.

Data bits and parity

The RS-232 interface can be configured to send/receive data that is 7 or 8 bits long using even, odd, or no parity. No parity is only valid when using 8 data bits.

Terminator

The Model 2520 can be configured to terminate each program message that it transmits to the controller with any of the following combinations of <CR> and <LF>:

<CR>	Carriage return
<CR+LF>	Carriage return and line feed
<LF>	Line feed
<LF+CR>	Line feed and carriage return

Flow control (signal handshaking)

Signal handshaking between the controller and the instrument lets the two devices communicate with each other about readiness to receive data. The Model 2520 does not support hardware handshaking (flow control).

Software flow control is in the form of XON and XOFF characters and is enabled when XON-XOFF is selected from the RS-232 FLOW CONTROL menu. When the input queue of the unit becomes more than 3/4 full, the instrument issues an XOFF command. The control program should respond to this and stop sending characters until the Model 2520 issues the XON, which it will do once its input buffer has dropped below half-full. The Model 2520 recognizes XON and XOFF sent from the controller. An XOFF will cause the instrument to stop outputting characters until it sees an XON. Incoming commands are processed after the <CR> character is received from the controller.

If NONE is the selected flow control, there will be no signal handshaking between the controller and the Model 2520. Data will be lost if transmitted before the receiving device is ready.

RS-232 connections

The RS-232 serial port ([Figure 10-3](#)) is connected to the serial port of a computer using a straight-through RS-232 cable terminated with DB-9 connectors such as a Keithley Model 7009-5. Do not use a null modem cable. The serial port uses the transmit (TXD), receive (RXD), and signal ground (GND) lines of the RS-232 standard.

[Figure 10-4](#) shows the rear panel connector for the RS-232 interface, and [Table 10-2](#) shows the pinout for the connector.

If your computer uses a DB-25 connector for the RS-232 interface, you will need a cable or adapter with a DB-25 connector on one end and a DB-9 connector on the other, wired straight through (not null modem).

Figure 10-4
RS-232 interface connector

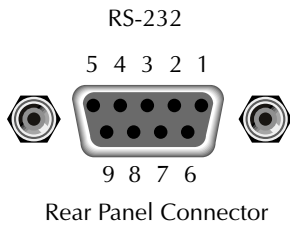

Table 10-2
RS-232 connector pinout

Pin number	Description
1	Not used
2	TXD, transmit data
3	RXD, receive data
4	Not used
5	GND, signal ground
6	Not used
7	RTS, ready to send
8	CTS, clear to send
9	Not used

Note: CTS and RTS are tied together.
Pins 1, 4, and 6 are tied together.

Table 10-3 provides pinout identification for the 9-pin (DB-9) or 25-pin (DB-25) serial port connector on the computer (PC).

Table 10-3
PC serial port pinout

Signal	DB-9 pin number	DB-25 pin number
DCD, data carrier detect	1	8
RXD, receive data	2	3
TXD, transmit data	3	2
DTR, data terminal ready	4	20
GND, signal ground	5	7
DSR, data set ready	6	6
RTS, request to send	7	4
CTS, clear to send	8	5
RI, ring indicator	9	22

Error messages

See [Appendix B](#) for RS-232 error messages.

Programming example

The following QuickBasic 4.5 programming example will control the Model 2520 via the RS-232 COM2 port. Place the Model 2520 into the RS-232 mode from the front panel main menu (press COMM then select RS-232). When the communication setting is changed, the Model 2520 will reset into that mode.

```

RD$ = SPACE$ (1500)           ' Set string space.
CLS                           ' Clear screen.
PRINT "Set COM2 baud rate to 9600"
PRINT "Set no flow control, and CR as terminator."

' Configure serial port parameters.
' The following values are the default settings for the Model 2520:
ComOpen$ = "COM2: 9600,N,8,1,ASC,CD0,CS0,DS0,LF,OP0,RS,TB8192,RB8192"
OPEN ComOpen$ FOR RANDOM AS #1

' Model 2520 setup commands:
PRINT #1,"*RST"               ' Reset instrument to default parameters.
PRINT #1,":SENS1:VOLT:RANG 3" ' Set 3V measure range.
PRINT #1,":SOUR1:CURR 0.1"   ' Set laser source to output 100mA.
PRINT #1,":FORM:ELEM VOLT1"  ' Set to output voltage readings to PC.

' Initiate a reading and print results:
PRINT #1,":READ?"           ' Trigger and acquire one reading.
LINE INPUT #1, RD$
RD$ = "Voltage: " + RD$
PRINT RD$

' Clean up and quit:
finish:
CLOSE #1                     ' Close file.
CLEAR                         ' Interface clear.
END

```

11

Status Structure

- **Overview** — Provides an operational overview of the status structure for the Model 2520.
- **Clearing registers and queues** — Covers the actions that clear (reset) registers and queues.
- **Programming and reading registers** — Explains how to program enable registers and read any register in the status structure.
- **Status byte and service request (SRQ)** — Explains how to program the Status Byte to generate service requests (SRQs). Shows how to use the serial poll sequence to detect SRQs.
- **Status register sets** — Provides bit identification and command information for the four status register sets: Standard Event Status, Operation Event Status, Measurement Event Status, and Questionable Event Status.
- **Queues** — Provides details and command information on the Output Queue and Error Queue.

Overview

The Model 2520 provides a series of status registers and queues allowing the operator to monitor and manipulate the various instrument events. The status structure is shown in [Figure 11-1](#). The heart of the status structure is the Status Byte Register. This register can be read by the user's test program to determine if a service request (SRQ) has occurred, and what event caused it.

Status byte and SRQ

The Status Byte Register receives the summary bits of four status register sets and two queues. The register sets and queues monitor the various instrument events. When an enabled event occurs, it sets a summary bit in the Status Byte Register. When a summary bit of the Status Byte is set and its corresponding enable bit is set (as programmed by the user), the RQS/MSS bit will set to indicate that an SRQ has occurred.

Status register sets

A typical status register set is made up of a condition register, an event register and an event enable register. A condition register is a read-only register that constantly updates to reflect the present operating conditions of the instrument.

When an event occurs, the appropriate event register bit sets to 1. The bit remains latched to 1 until the register is reset. When an event register bit is set and its corresponding enable bit is set (as programmed by the user), the output (summary) of the register will set to 1, which in turn sets the summary bit of the Status Byte Register.

Queues

The Model 2520 uses an Output Queue and an Error Queue. The response messages to query commands are placed in the Output Queue. As various programming errors and status messages occur, they are placed in the Error Queue. When a queue contains data, it sets the appropriate summary bit of the Status Byte Register.

Figure 11-1
Model 2520 status register structure

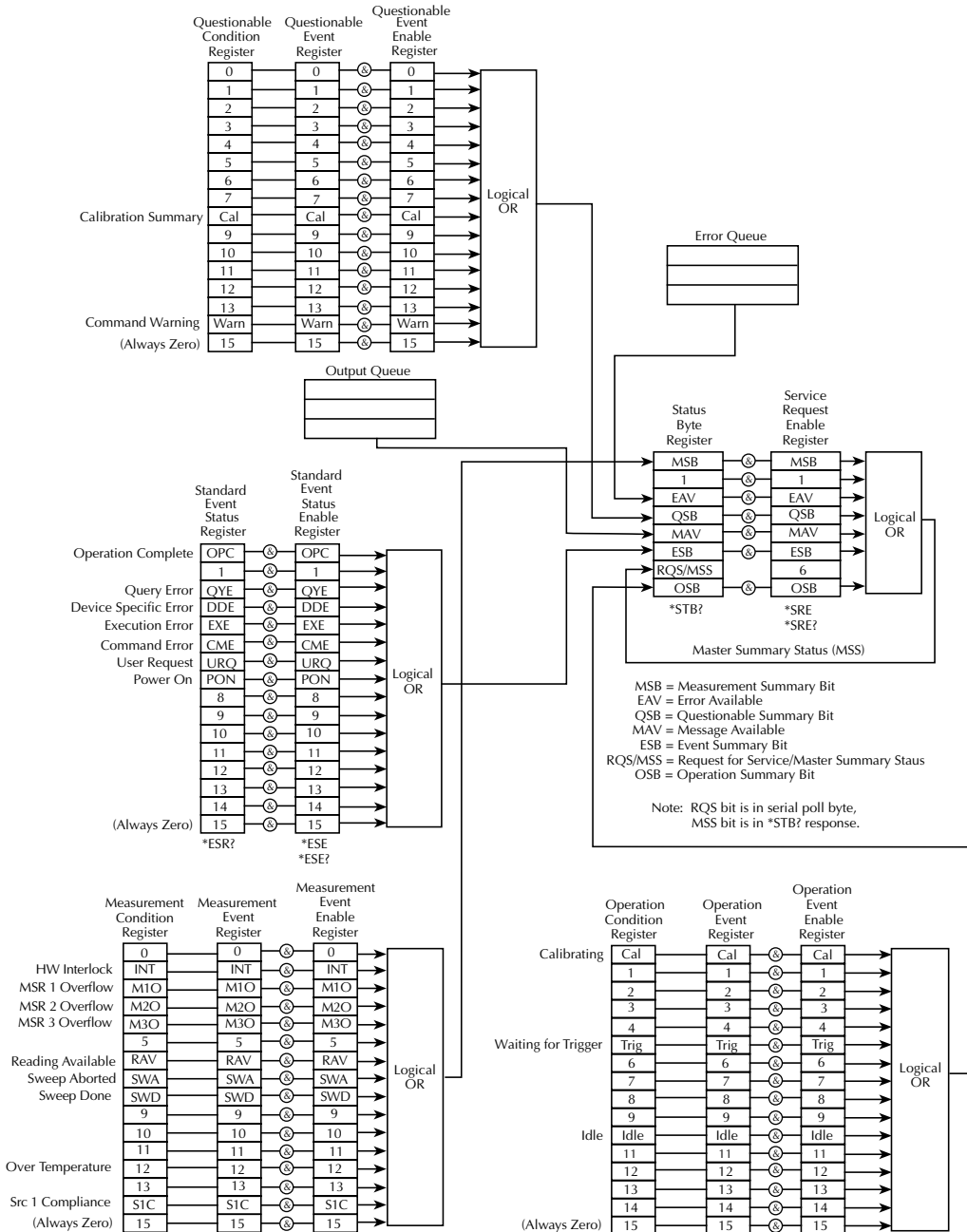

Clearing registers and queues

When the Model 2520 is turned on, the bits of all registers in the status structure are cleared (reset to 0), and the two queues are empty. Commands to reset the event and event enable registers, and the Error Queue are listed in [Table 11-1](#). In addition to these commands, any enable register can be reset by sending the 0 parameter value with the individual command to program the register.

NOTE *SYSTEM:PRESet and *RST have no effect on status structure registers and queues.*

Table 11-1

Common and SCPI commands to reset registers and clear queues

Commands	Description	Ref.
To Reset Registers: *CLS	Reset all bits of the following event registers to 0: Standard Event Register Operation Event Register Measurement Event Register Questionable Event Register	Note 1
:STATus:PRESet	Reset all bits of the following enable registers to 0: Operation Event Enable Register Measurement Event Enable Register Questionable Event Enable Register	Note 1
To Clear Error Queue: *CLS	Clear all messages from Error Queue	Note 2
:STATus:QUEue:CLEar	Clear messages from Error Queue	Note 3

Notes:

1. The Standard Event Enable Register is not reset by STATus:PRESet or *CLS. Send the 0 parameter value with *ESE to reset all bits of that enable register to 0. See “Status byte and service request commands,” [page 11-10](#).
2. STATus:PRESet has no effect on the Error Queue.
3. Use either of the two clear commands to clear the Error Queue.

Programming and reading registers

Programming enable registers

The only registers that can be programmed by the user are the enable registers. All other registers in the status structure are read-only registers. The following explains how to ascertain the parameter values for the various commands used to program enable registers. The actual commands are covered later in this section (Table 11-3 and Table 11-6).

A command to program an event enable register is sent with a parameter value that determines the desired state (0 or 1) of each bit in the appropriate register. An enable register can be programmed using any of the following data formats for the parameter value: binary, decimal, hexadecimal, or octal.

The bit positions of the register () indicate the binary parameter value. For example, if you wish to set bits B4, B3, and B1, the binary value would be 11010 (where B4=1, B3=1, B1=1, and all other bits are 0). When you use one of the other formats, convert the binary number to its decimal, hexadecimal, or octal equivalent:

Binary 11010 = Decimal 26 = Hexadecimal 1A = Octal 32

Note that Figure 11-2 includes the decimal weight for each register bit. To set bits B4, B3, and B1, the decimal parameter value would be the sum of the decimal weights for those bits ($16+8+2 = 26$).

Figure 11-2
16-bit status register

Bit Position	B7	B6	B5	B4	B3	B2	B1	B0
Binary Value	0/1	0/1	0/1	0/1	0/1	0/1	0/1	0/1
Decimal	128	64	32	16	8	4	2	1
Weights	(2 ⁷)	(2 ⁶)	(2 ⁵)	(2 ⁴)	(2 ³)	(2 ²)	(2 ¹)	(2 ⁰)

A. Bits 0 through 7

Bit Position	B15	B14	B13	B12	B11	B10	B9	B8
Binary Value	0/1	0/1	0/1	0/1	0/1	0/1	0/1	0/1
Decimal	32768	16384	8192	4096	2048	1024	512	256
Weights	(2 ¹⁵)	(2 ¹⁴)	(2 ¹³)	(2 ¹²)	(2 ¹¹)	(2 ¹⁰)	(2 ⁹)	(2 ⁸)

B. Bits 8 through 15

The <NDN> (non-decimal numeric) parameter type is used to send non-decimal values. These values require a header (#B, #H, or #Q) to identify the data format being sent. The letter in the header can be upper or lower case. The <NRf> (numeric representation format) parameter type is used to send decimal values, and does not use a header. The following examples show the proper parameter syntax for setting Bits B5, B3, and B2:

#b101100 Binary format (<NDN> parameter type)

#h2C Hexadecimal format (<NDN> parameter type)

#q54 Octal format (<NDN> parameter type)

44 Decimal format (<NRf> parameter type)

Valid characters for the non-decimal parameter values are shown as follows:

<NDN> format	Valid characters
Binary	1s and 0s
Hexadecimal	0 through 9 and A through F
Octal	0 through 7

Reading registers

Any register in the status structure can be read by using the appropriate query (?) command. The following explains how to interpret the returned value (response message). The actual query commands are covered later in this section (Table 11-3 through Table 11-7).

The response message will be a value that indicates which bits in the register are set. That value (if not already binary) will have to be converted to its binary equivalent. For example, for a binary value of 100101, bits B5, B2, and B0 are set.

The returned value can be in the binary, decimal, hexadecimal, or octal format. The Format:SREGister command is used to select the data format for the returned value (Table 11-2).

For non-decimal formats, one of the following headers will accompany the returned value to indicate which format is selected:

#B = Header for binary values

#H = Header for hexadecimal values

#Q = Header for octal values

Table 11-2
Data format commands for reading status registers

Command	Description	Default
:FORMat:SREGister <name>	Select data format for reading status registers: <name> = ASCii Decimal format HEXadecimal Hexadecimal format OCTal Octal format BINary Binary format	ASCii

Status byte and service request (SRQ)

Service request is controlled by two 8-bit registers; the Status Byte Register and the Service Request Enable Register. Figure 11-3 shows the structure of these registers.

Figure 11-3
Status byte and service request (SRQ)

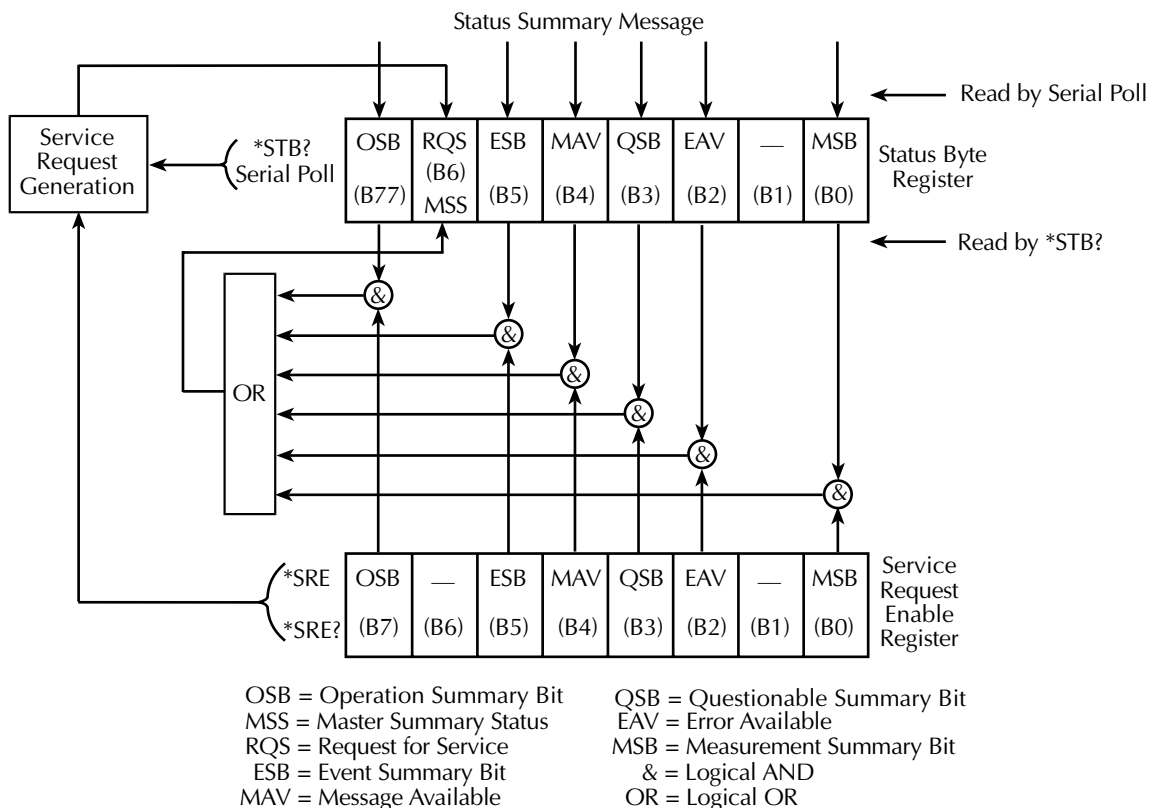

Status byte register

The summary messages from the status registers and queues are used to set or clear the appropriate bits (B0, B2, B3, B4, B5, and B7) of the Status Byte Register. These summary bits do not latch, and their states (0 or 1) are solely dependent on the summary messages (0 or 1). For example, if the Standard Event Register is read, its register will clear. As a result, its summary message will reset to 0, which in turn will reset the ESB bit in the Status Byte Register.

The bits of the Status Byte Register are described as follows:

- **Bit B0, Measurement Summary Bit (MSB)** — Set summary bit indicates that an enabled measurement event has occurred.
- **Bit B1** — Not used.
- **Bit B2, Error Available (EAV)** — Set summary bit indicates that an error or status message is present in the Error Queue.
- **Bit B3, Questionable Summary Bit (QSB)** — Set summary bit indicates that an enabled questionable event has occurred.
- **Bit B4, Message Available (MAV)** — Set summary bit indicates that a response message is present in the Output Queue.
- **Bit B5, Event Summary Bit (ESB)** — Set summary bit indicates that an enabled standard event has occurred.
- **Bit B6, Request Service (RQS)/Master Summary Status (MSS)** — Set bit indicates that an enabled summary bit of the Status Byte Register is set.
- **Bit B7, Operation Summary (OSB)** — Set summary bit indicates that an enabled operation event has occurred.

Depending on how it is used, Bit B6 of the Status Byte Register is either the Request for Service (RQS) bit or the Master Summary Status (MSS) bit:

- When using the serial poll sequence of the Model 2520 to obtain the status byte (a.k.a. serial poll byte), B6 is the RQS bit. See “[Serial polling and SRQ](#),” page 11-9 for details on using the serial poll sequence.
- When using the *STB? command ([Table 11-3](#)) to read the status byte, B6 is the MSS bit.

Service request enable register

The generation of a service request is controlled by the Service Request Enable Register. This register is programmed by you and is used to enable or disable the setting of bit B6 (RQS/MSS) by the Status Summary Message bits (B0, B2, B3, B4, B5, and B7) of the Status Byte Register. As shown in [Figure 11-3](#), the summary bits are logically ANDed (&) with the corresponding enable bits of the Service Request Enable Register. When a set (1) summary bit is ANDed with an enabled (1) bit of the enable register, the logic “1” output

is applied to the input of the OR gate and, therefore, sets the MSS/RQS bit in the Status Byte Register.

The individual bits of the Service Request Enable Register can be set or cleared by using the *SRE common command. To read the Service Request Enable Register, use the *SRE? query command. The Service Request Enable Register clears when power is cycled or a parameter value of 0 is sent with the *SRE command (i.e. *SRE 0). The commands to program and read the SRQ Enable Register are listed in [Table 11-3](#).

Serial polling and SRQ

Any enabled event summary bit that goes from 0 to 1 will set bit B6 and generate an SRQ (service request). In your test program, you can periodically read the Status Byte to check if an SRQ has occurred and what caused it. If an SRQ occurs, the program can, for example, branch to an appropriate subroutine that will service the request.

Typically, SRQs are managed by the serial poll sequence of the Model 2520. If an SRQ does not occur, bit B6 (RQS) of the Status Byte Register will remain cleared, and the program will simply proceed normally after the serial poll is performed. If an SRQ does occur, bit B6 of the Status Byte Register will set, and the program can branch to a service subroutine when the SRQ is detected by the serial poll.

The serial poll automatically resets RQS of the Status Byte Register. This allows subsequent serial polls to monitor bit B6 for an SRQ occurrence generated by other event types. After a serial poll, the same event can cause another SRQ, even if the event register that caused the first SRQ has not been cleared.

The serial poll does not clear MSS. The MSS bit stays set until all Status Byte summary bits are reset.

SPE, SPD (serial polling)

The SPE, SPD General Bus Command sequence is used to serial poll the Model 2520. Serial polling obtains the serial poll byte (status byte). Typically, serial polling is used by the controller to determine which of several instruments has requested service with the SRQ line.

Status byte and service request commands

The commands to program and read the Status Byte Register and Service Request Enable Register are listed in Table 11-3. For details on programming and reading registers, see “Programming enable registers,” page 11-5, and “Reading registers,” page 11-6.

NOTE To reset the bits of the Service Request Enable Register to 0, use 0 as the parameter value for the *SRE command (i.e. *SRE 0).

Table 11-3
Status byte and service request enable register commands

Command	Description	Default
*STB? *SRE <NDN> or <NRf>	Read Status Byte Register. Program the Service Request Enable Register: <NDN> = #Bxx...x Binary format (each x = 1 or 0) = #Hx Hexadecimal format (x = 0 to FF) = #Qx Octal format (x = 0 to 377) <NRf> = 0 to 255 Decimal format	Note
*SRE?	Read the Service Request Enable Register	

Note: *CLS and STATUS:PRESet have no effect on the Service Request Enable Register.

Programming example - set MSS (B6) when error occurs

The first command of sequence in Table 11-4 enables EAV (error available). When an invalid command is sent (line 4), bits B2 (EAV) and B6 (MSS) of the Status Byte Register set to 1. The last command reads the Status Byte Register using the binary format (which directly indicates which bits are set). The command to select format (FORMAT:SREGister) is documented in Table 11-2. To determine the exact nature of the error, you will have to read the Error Queue. Refer to “Queues,” page 11-19.

Table 11-4
Status byte programming example

Command	Description
*CLS	Clear Error Queue.
*SRE 4	Enable EAV.
FORM:SREG BIN	Select binary format.
*XYZ	Generate error.
*STB?	Read Status Byte Register.

Status register sets

As shown in [Figure 11-1](#), there are four status register sets in the status structure of the Model 2520: Standard Event Status, Operation Event Status, Measurement Event Status, and Questionable Event Status.

NOTE See [Appendix B](#) for details on which register bits are set by specific error and status conditions.

Register bit descriptions

Standard event register

The used bits of the Standard Event Register (shown in [Figure 11-4](#)) are described as follows:

- **Bit B0, Operation Complete** — Set bit indicates that all pending selected device operations are completed and the Model 2520 is ready to accept new commands. This bit only sets in response to the *OPC? query command. See [Section 12](#) for details on *OPC and *OPC?.
- **Bit B1** — Not used.
- **Bit B2, Query Error (QYE)** — Set bit indicates that you attempted to read data from an empty Output Queue.
- **Bit B3, Device-Dependent Error (DDE)** — Set bit indicates that an instrument operation did not execute properly due to some internal condition.
- **Bit B4, Execution Error (EXE)** — Set bit indicates that the Model 2520 detected an error while trying to execute a command.
- **Bit B5, Command Error (CME)** — Set bit indicates that a command error has occurred.
 - Command errors include:
 - IEEE-488.2 syntax error — Model 2520 received a message that does not follow the defined syntax of the IEEE-488.2 standard.
 - Semantic error — Model 2520 received a command that was misspelled or received an optional IEEE-488.2 command that is not implemented.
 - The instrument received a Group Execute Trigger (GET) inside a program message.
- **Bit B6, User Request (URQ)** — Set bit indicates that the LOCAL key on the Model 2520 front panel was pressed.
- **Bit B7, Power ON (PON)** — Set bit indicates that the Model 2520 has been turned off and turned back on since the last time this register has been read.

Figure 11-4
Standard event status

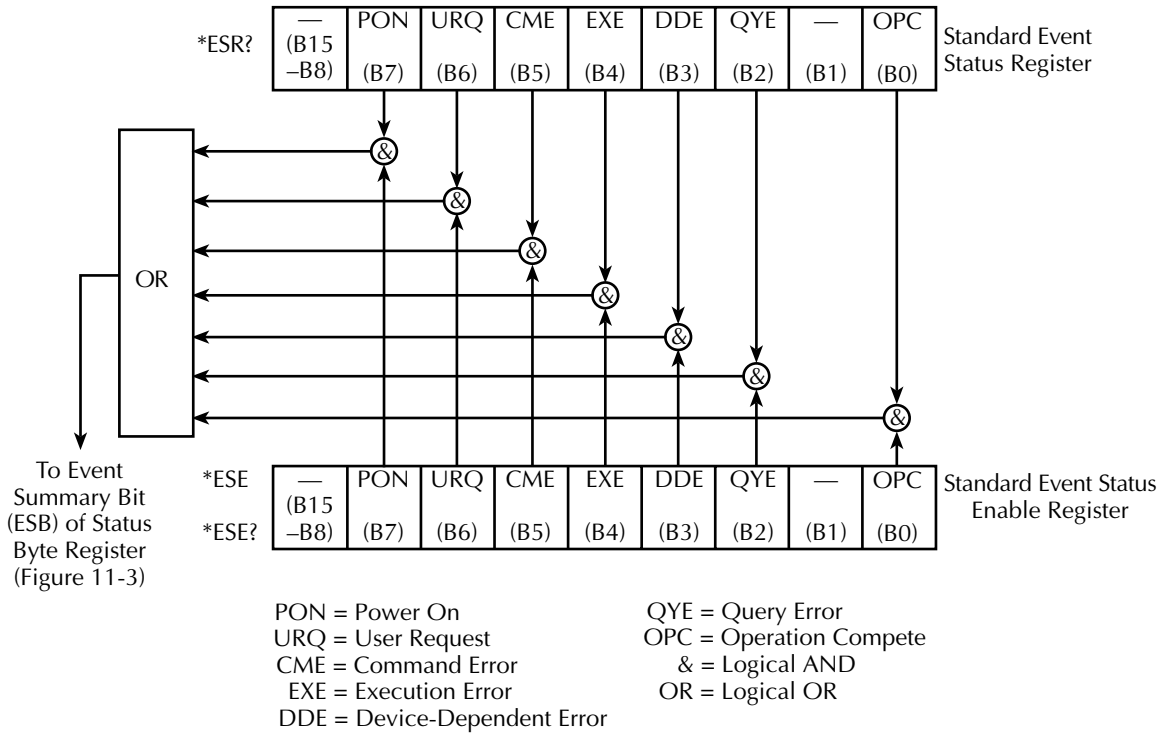

Operation event register

The used bits of the Operation Event Register (shown in Figure 11-5) are described as follows:

- **Bit B0, Calibrating (Cal)** — Set bit indicates that the Model 2520 is calibrating.
- **Bits B1 through B4** — Not used.
- **Bit B5, Waiting for Trigger Event (Trig)** — Set bit indicates that the Model 2520 is in the trigger layer waiting for a TLINK trigger event to occur.
- **Bits B6 through B9** — Not used.
- **Bit B10, Idle State (Idle)** — Set bit indicates the Model 2520 is in the idle state.
- **Bits B11 through B15** — Not used.

Figure 11-5
Operation event status

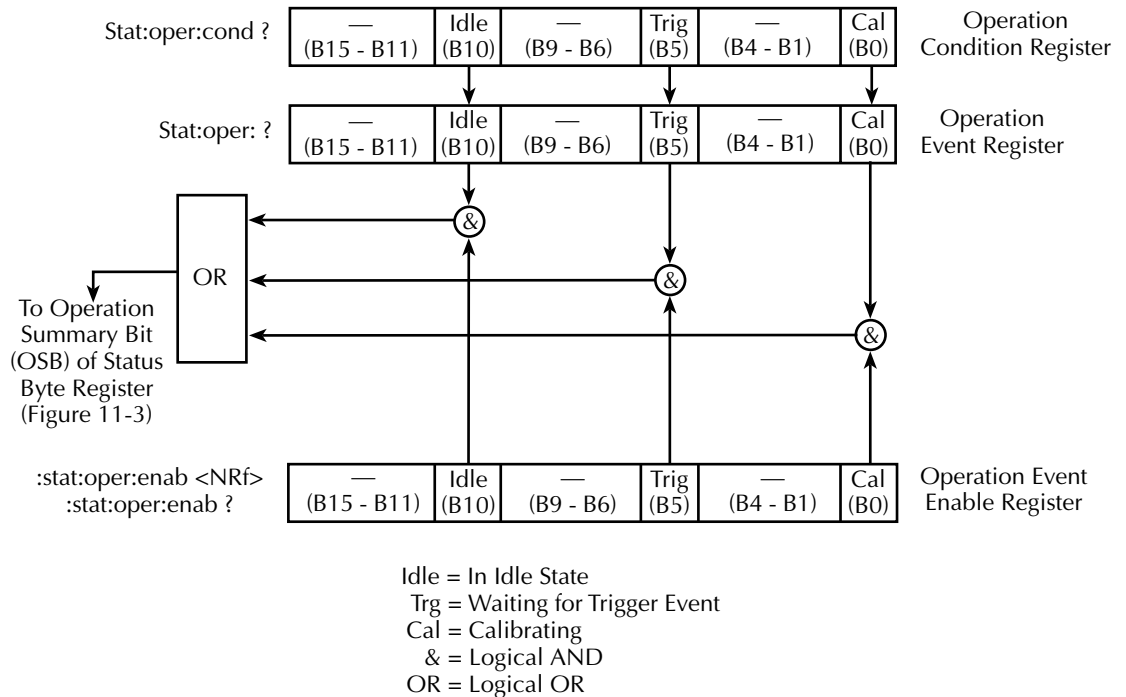

Measurement event register

The used bits of the Measurement Event Register (shown in [Figure 11-6](#)) are described as follows:

- **Bit B0** — Not used.
- **Bit B1, HW Interlock (INT)** — Set bit indicates that the hardware interlock line on the testhead is at a digital low (asserted). Outputs can be turned on.
- **Bit B2, MSR1 Overflow (M1O)** — Set bit indicates that the laser diode voltage measurement is in an overflow condition.
- **Bit B3, MSR2 Overflow (M2O)** — Set bit indicates that the photodiode detector #1 current measurement is in an overflow condition.
- **Bit B4, MSR3 Overflow (M3O)** — Set bit indicates that the photodiode detector #2 current measurement is in an overflow condition.
- **Bit B5** — Not used.
- **Bit B6, Reading Available (RAV)** — Set bit indicates that a reading has been processed and is available.
- **Bit B7, Sweep Aborted (SWA)** — Set bit indicates that the sweep was aborted before being completed.
- **Bit B8, Sweep Done (SWD)** — Set bit indicates a sweep was completed successfully.
- **Bits B9 to B11** — Not used.
- **Bit B12, Over Temperature (OT)** — Set bit indicates that safe operating temperature of the testhead has been exceeded. Outputs cannot be turned on.
- **Bit B13** — Not used.
- **Bit B14, Source 1 Compliance (S1C)** — Set bit indicates that the laser diode current source is in compliance.
- **Bit B15** — Not used.

Figure 11-6
Measurement event status

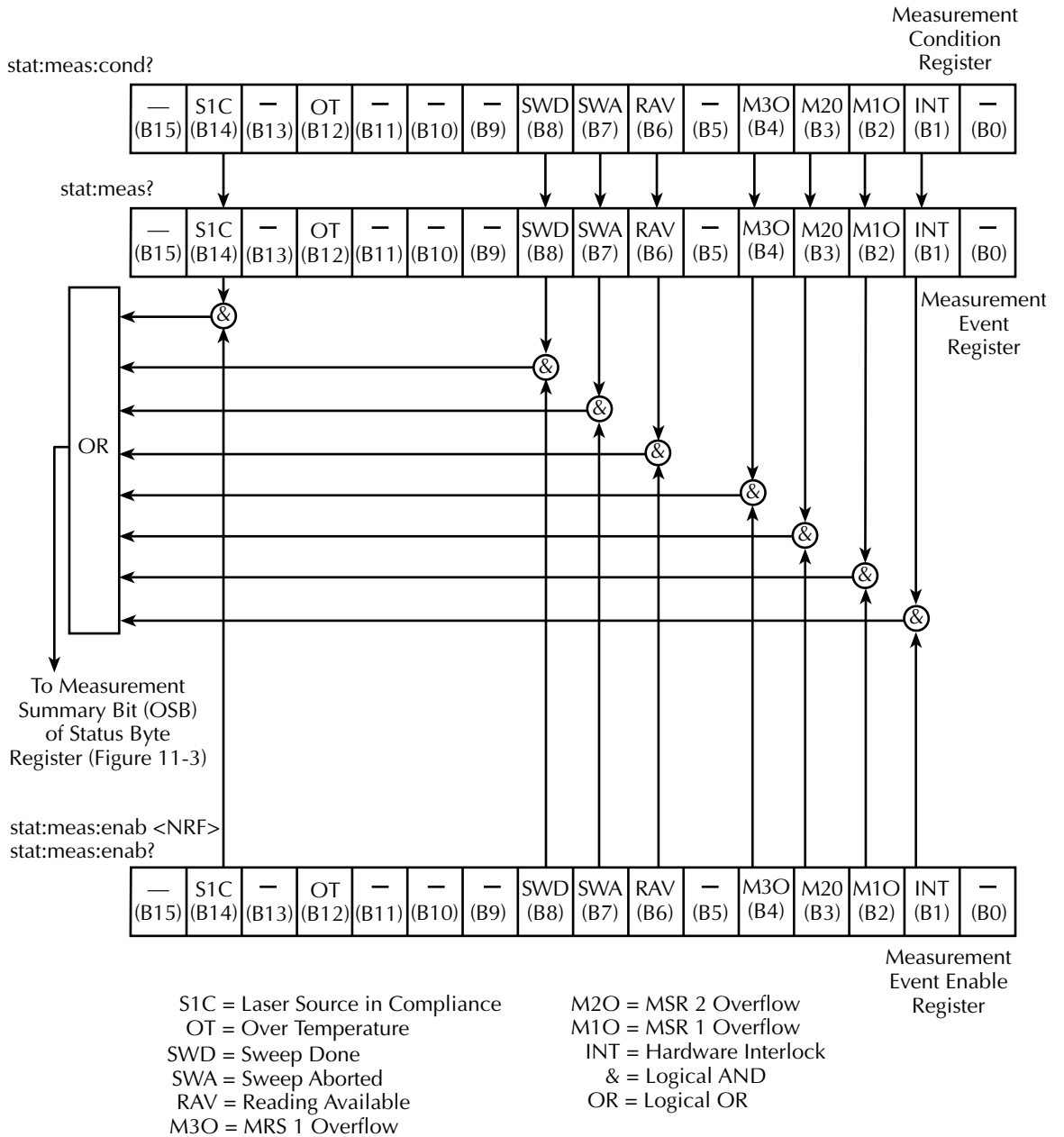

Questionable event register

The used bits of the Questionable Event Register (shown in Figure 11-7) are described as follows:

- **Bits B0 through B7** — Not used.
- **Bit B8, Calibration Summary (Cal)** — Set bit indicates that an invalid calibration constant was detected during the power-up sequence. This error will clear after successful calibration of the instrument.
- **Bits B9 through B13** — Not used.
- **Bit B14, Command Warning (Warn)** — Set bit indicates that a Signal Oriented Measurement Command parameter has been ignored.
- **Bit B15** — Not used.

Figure 11-7
Questionable event status

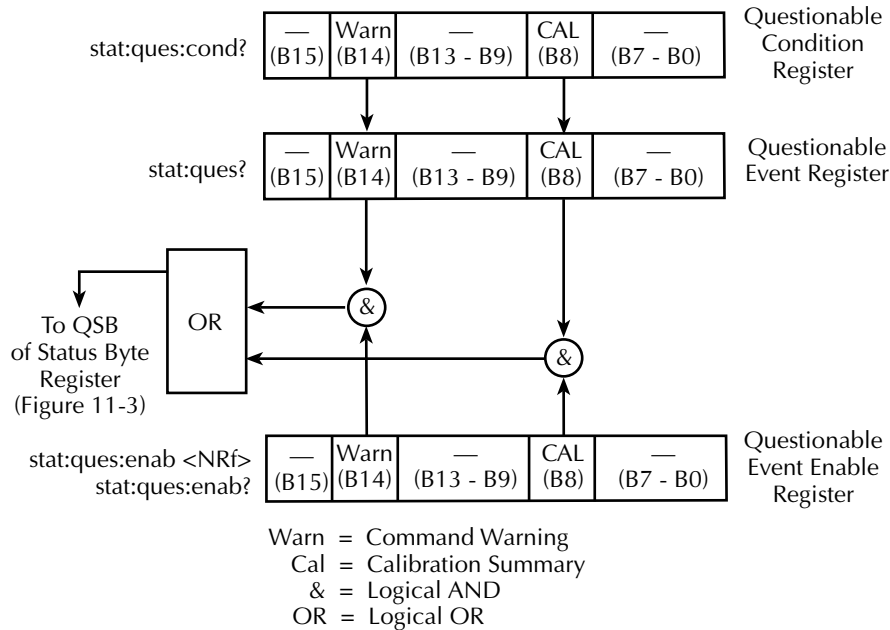

Condition registers

As [Figure 11-1](#) shows, each status register set (except the Standard Event Register set) has a condition register. A condition register is a real-time, read-only register that constantly updates to reflect the present operating conditions of the instrument. For example, while the Model 2520 is in the idle state, bit B10 (Idle) of the Operation Condition Register will be set. When the instrument is taken out of idle, bit B10 clears.

The commands to read the condition registers are listed in [Table 11-5](#). For details on reading registers, see “[Reading registers](#),” page 11-6.

Table 11-5

Condition register commands

Command	Description
:STATus:OPERation:CONDition?	Read Operation Condition Register.
:STATus:MEASurement:CONDition?	Read Measurement Condition Register.
:STATus:QUESTionable:CONDition?	Read Questionable Condition Register.

Event registers

As [Figure 11-1](#) shows, each status register set has an event register. When an event occurs, the appropriate event register bit sets to 1. The bit remains latched to 1 until the register is reset. Reading an event register clears the bits of that register. *CLS resets all four event registers.

The commands to read the event registers are listed in [Table 11-6](#). For details on reading registers, see “[Reading registers](#),” page 11-6.

Table 11-6

Event register commands

Command	Description	Default
*ESR?	Read Standard Event Status Register.	Note
:STATus:OPERation:[:EVENT]?	Read Operation Event Register.	
:STATus:MEASurement:[:EVENT]?	Read Measurement Event Register.	
:STATus:QUESTionable:[:EVENT]?	Read Questionable Event Register.	

Note: Power-up and *CLS resets all bits of all event registers to 0. STATus:PRESet has no effect.

Event enable registers

As [Figure 11-1](#) shows, each status register set has an enable register. Each event register bit is logically ANDed (&) to a corresponding enable bit of an enable register. Therefore, when an event bit is set and the corresponding enable bit is set (as programmed by the user), the output (summary) of the register will set to 1, which in turn sets the summary bit of the Status Byte Register.

The commands to program and read the event enable registers are listed in [Table 11-7](#). For details on programming and reading registers, see “[Programming enable registers,](#)” [page 11-5](#), and “[Reading registers,](#)” [page 11-6](#).

NOTE *The bits of any enable register can be reset to 0 by sending the 0 parameter value with the appropriate enable command (i.e. STATUS:OPERation:ENABLE 0).*

Table 11-7

Event enable registers commands

Command	Description	Default
*ESE <NDN> or <NRf> *ESE?	Program Standard Event Enable Register. See <i>Parameters</i> . Read Standard Event Enable Register.	Note
STATus :OPERation :ENABLE <NDN> or <NRf> :ENABLE? :MEASurement :ENABLE <NDN> or <NRf> :ENABLE? :QUESTionable :ENABLE <NDN> or <NRf> :ENABLE?	STATus Subsystem: Operation Event Enable Register: Program enable register. See <i>Parameters</i> . Read enable register. Measurement Event Enable Register: Program enable register. See <i>Parameters</i> . Read enable register. Questionable Event Enable Register: Program enable register. See <i>Parameters</i> . Read Measurement Event Enable Register:	
Parameters: <NDN> = #Bxx...x = #Hx = #Qx <NRf> = 0 to 65535	Binary format (each x = 1 or 0) Hexadecimal format (x = 0 to FFFF) Octal format (x = 0 to 177777) Decimal format	

Note: Power-up and STATus:PRESet resets all bits of all enable registers to 0. *CLS has no effect.

Programming example - program and read register set

The command sequence in [Table 11-8](#) programs and reads the measurement register set. Registers are read using the binary format (which directly indicates which bits are set). The command to select format (FORMat:SREGister) is documented in [Table 11-2](#).

Table 11-8

Program and read register programming example

Command	Description
FORM:SREG BIN	Select binary format to read registers.
STAT:MEAS:ENAB 512	Enable BFL (buffer full).
STAT:MEAS:COND?	Read Measurement Condition Register.
STAT:MEAS?	Read Measurement Event Register.

Queues

The Model 2520 uses two queues, which are first-in, first-out (FIFO) registers:

- **Output Queue** — Used to hold reading and response messages.
- **Error Queue** — Used to hold error and status messages. (See [Appendix B](#).)

The Model 2520 status model ([Figure 11-1](#)) shows how the two queues are structured with the other registers.

Output queue

The output queue holds data that pertains to the normal operation of the instrument. For example, when a query command is sent, the response message is placed in the Output Queue.

When data is placed in the Output Queue, the Message Available (MAV) bit in the Status Byte Register sets. A data message is cleared from the Output Queue when it is read. The Output Queue is considered cleared when it is empty. An empty Output Queue clears the MAV bit in the Status Byte Register.

A message is read from the Output Queue by addressing the Model 2520 to talk after the appropriate query is sent.

Error queue

The Error Queue holds error and status messages. When an error or status event occurs, a message that defines the error/status is placed in the Error Queue.

When a message is placed in the Error Queue, the Error Available (EAV) bit in the Status Byte Register is set. An error/status message is cleared from the Error Queue when it is read. The Error Queue is considered cleared when it is empty. An empty Error Queue clears the EAV bit in the Status Byte Register.

The Error Queue holds up to 10 error/status messages. The commands to read the Error Queue are listed in [Table 11-9](#). When you read a single message in the Error Queue, the “oldest” message is read and then removed from the queue. If the queue becomes full, the message “350, ‘Queue Overflow’” will occupy the last memory location. On power-up, the Error Queue is empty. When empty, the message “0, No Error” is placed in the queue.

Messages in the Error Queue are preceded by a code number. Negative (-) numbers are used for SCPI-defined messages, and positive (+) numbers are used for Keithley-defined messages. The messages are listed in [Appendix B](#). As shown in [Table 11-7](#), there are commands to read the entire message (code and message) or the code only.

On power-up, all error messages are enabled and will go into the Error Queue as they occur. Status messages are not enabled and will not go into the queue. As listed in [Table 11-9](#), there are commands to enable and/or disable messages. For these commands, the <list> parameter is used to specify which messages to enable or disable. The messages are specified by their codes. The following examples show various forms for using the <list> parameter.

<list> = (-110)	Single message
= (-110:-222)	Range of messages (-110 through -222)
= (-110:-222, -220)	Range entry and single entry (separated by a comma)

When you enable messages, messages not specified in the list are disabled. When you disable messages, each listed message is removed from the enabled list.

NOTE To prevent all messages from entering the Error Queue, send the enable command along with the null list parameter as follows: `STATus:QUEue:ENABLE ()`.

Table 11-9
Error queue commands

Command	Description	Default
STATus :QUEue [:NEXT]? :ENABle <list> :ENABle? :DISABle <list> :DISABle? :CLEar	STATus Subsystem: Read Error Queue: Read and clear oldest error/status (code and message). Specify error and status messages for Error Queue. Read the enabled messages. Specify messages not to be placed in queue. Read the disabled messages. Clear messages from Error Queue.	Note 1 Note 2 Note 2
SYSTem :ERRor [:NEXT]? :ALL? :COUNT? :CODE [:NEXT]? :ALL?	SYSTem Subsystem: Read Error Queue: Read and clear oldest error/status (code and message). Read and clear all errors/status (code and message). Read the number of messages in queue. Code numbers only: Read and clear oldest error/status (code only). Read and clear all errors/status (codes only).	Note 1

Notes:

1. Power-up and *CLS empties the Error Queue. STATus:PRESet has no effect.
2. Power-up enables error messages and disables status messages. *CLS and STATus:PRESet have no effect.

Programming example - read error queue

The following command reads the error queue:

```
STAT:QUE?
```

12 Common Commands

- **Command summary** — Lists the IEEE-488.2 common commands used by the Model 2520.
- **Command reference** — Provides a detailed reference for all common commands except for those associated with the status structure, which are discussed in [Section 11](#).

Command summary

Common commands (summarized in [Table 12-1](#)) are device commands that are common to all devices on the bus. These commands are designated and defined by the IEEE-488.2 standard. Most of these commands are described in detail in this section.

NOTE *The following common commands associated with the status structure are covered in [Section 11](#): *CLS, *ESE, *ESE?, *ESR?, *SRE, *SRE?, and *STB?.*

Table 12-1
IEEE-488.2 common commands and queries

Mnemonic	Name	Description
*CLS	Clear status	Clears all event registers and Error Queue. ¹
*ESE <NRf>	Event enable command	Program the Standard Event Enable Register. ¹
*ESE?	Event enable query	Read the Standard Event Enable Register. ¹
*ESR?	Event status register query	Read and clear the Standard Event Enable Register. ¹
*IDN?	Identification query	Returns the manufacturer, model number, serial number, and firmware revision levels of the unit.
*OPC	Operation complete command	Set the Operation Complete bit in the Standard Event Register after all pending commands have been executed.
*OPC?	Operation complete query	Places an ASCII "1" into the Output Queue when all pending selected device operations have been completed.
*OPT?	Option query	Query Model 2520 for list of installed options.
*RCL <NRf>	Recall command	Returns the Model 2520 to the user-saved setup.
*RST	Reset command	Returns the Model 2520 to the *RST default conditions.
*SAV <NRf>	Save command	Saves the present setup as the user-saved setup.
*SRE <NRf>	Service request enable command	Programs the Service Request Enable Register. ¹
*SRE?	Service request enable query	Reads the Service Request Enable Register. ¹
*STB?	Status byte query	Reads the Status Byte Register. ¹
*TRG	Trigger command	Sends a bus trigger to the Model 2520.
*TST?	Self-test query	Performs a checksum test on ROM and returns the result.
*WAI	Wait-to-continue command	Wait until all previous commands are executed.

¹ Status commands are covered in [Section 11](#).

Command reference

***IDN? — identification query**

Reads identification code

The identification code includes the manufacturer, model number, serial number, and firmware revision levels and is sent in the following format:

```
KEITHLEY INSTRUMENTS INC., MODEL 2520, xxxxxxx, yyyyyy, zzzzz mmm ddd  
yyyy ++:++:++ /aaa/bbb/c/d/e
```

Where: xxxxxxx is the mainframe serial number.

yyyyyy is the testhead serial number.

zzzzz is the main microprocessor firmware revision.

Mmm dd yyyy is the month, day, and year of the firmware release.

aaa is the display board revision level.

bbb is the DSP firmware revision level.

c is the mainframe board revision level.

d is the testhead measurement board revision level.

e is the testhead pulser board revision level.

***OPC — operation complete**

Sets OPC bit

***OPC? — operation complete query**

Places a "1" in output queue

When *OPC is sent, the OPC bit in the Standard Event Register will set after all pending command operations are complete. When *OPC? is sent, an ASCII "1" is placed in the Output Queue after all pending command operations are complete.

Typically, either one of these commands is sent after the INITiate command. The INITiate command is used to take the instrument out of idle in order to perform measurements.

While operating within the trigger model layers, all sent commands (except DCL, SDC, IFC, SYSTem:PRESet, *RST, *RCL, *TRG, GET, and ABORt) will not execute.

After all programmed operations are completed, the instrument returns to the idle state at which time all pending commands (including *OPC and/or *OPC?) are executed. After the last pending command is executed, the OPC bit and/or an ASCII "1" is placed in the Output Queue.

*OPC programming example

The command sequence in Table 12-2 will perform 10 measurements. After the measurements are completed (in approximately 10 seconds), an ASCII "1" will be placed in the Output Queue and displayed on the computer CRT. Note that additional codes must be added to query the instrument for the presence of the ASCII "1" in the Output Queue.

Table 12-2

*OPC programming example

Command	Description
*RST	Return Model 2520 to GPIB defaults (idle).
:TRIG:COUN 10	Program for 10 measurements and stop.
:OUTP1 ON	Turn on output.
:INIT	Start measurements.
*OPC?	Send *OPC? to query Output Queue.*

* Additional code required to test for "1" in Output Queue.

*OPT? — option query

Return list of installed options

When *OPT? is sent, Model 2520 returns a list of any installed options.

*SAV <NRf> — save

Save present setup in memory

*RCL <NRf> — recall

Return to setup stored in memory

Parameters: 0 = Memory location 0

1 = Memory location 1

2 = Memory location 2

3 = Memory location 3

4 = Memory location 4

Use the *SAV command to save the present instrument setup configuration in memory for later recall. Any control affected by *RST can be saved by the *SAV command. The *RCL command is used to restore the instrument to the saved setup configuration. Five setup configurations can be saved and recalled.

The Model 2520 ships from the factory with SYSTem:PRESet defaults loaded into the available setup memory. If a recall error occurs, the setup memory defaults to the SYSTem:PRESet values.

***SAV, *RCL programming example**

Table 12-3 summarizes the basic command sequence for saving and recalling a setup. The present setup is stored in memory location 2, GPIB defaults are restored, and the memory location 2 setup is recalled.

Table 12-3

***SAV, *RCL programming example**

Command	Description
*SAV 2	Save present setup in memory location 2.
*RST	Restore GPIB defaults.
*RCL 2	Recall location 2 setup.

RST — reset*Return Model 2520 to GPIB defaults**

When the *RST command is sent, the Model 2520 performs the following operations:

- Returns the Model 2520 to the GPIB default conditions. Refer to “Default parameters” column of SCPI tables in [Section 14](#).
- Cancels all pending commands.
- Cancels response to any previously received *OPC and *OPC? commands.

TRG — trigger*Send bus trigger to Model 2520**

Use the *TRG command to issue a GPIB trigger to the Model 2520. It has the same effect as a group execute trigger (GET).

Use the *TRG command as an event to control operation. The Model 2520 reacts to this trigger if BUS is the programmed arm control source using the :TRIG:SOUR BUS command.

NOTE Details on triggering are covered in [Section 8](#).

***TRG programming example**

The command sequence in [Table 12-4](#) configures the Model 2520 to be controlled by bus triggers. The last command, which sends a bus trigger, triggers one measurement. Each subsequent bus trigger will also trigger a single measurement.

NOTE With :TRIG:SOURce BUS selected, do not send any commands (except *TRG, GET, DCL, SDC, IFC, and ABORt) while performing source-measure operations. Otherwise, erratic operation will occur.

Table 12-4
***TRG programming example**

Command	Description
*RST	Restore GPIB defaults.
:TRIG:SOUR BUS	Select BUS trigger control source.
:TRIG:COUN INF	Set trigger layer count to infinite.
:OUTP1 ON	Turn on output.
:INIT	Take Model 2520 out of idle.
*TRG	Trigger one measurement.

***TST? — self-test query**

Run self test and read result

Use this query command to perform a checksum test on ROM. The command places the coded result (0 or 1) in the Output Queue. When the Model 2520 is addressed to talk, the coded result is sent from the Output Queue to the computer.

A returned value of zero (0) indicates that the test passed, and a value of one (1) indicates that the test failed.

***WAI — wait-to-continue**

Wait until previous commands are completed

Effectively, the *WAI command is a No-Op (no operation) for the Model 2520 and thus, does not need to be used.

Two types of device commands exist:

- Sequential commands — A command whose operations are allowed to finish before the next command is executed.
- Overlapped commands — A command that allows the execution of subsequent commands while device operations of the Overlapped command are still in progress.

The *WAI command is used to suspend the execution of subsequent commands until the device operations of all previous Overlapped commands are finished. The *WAI command is not needed for Sequential commands.

13

SCPI Signal-Oriented Measurement Commands

- **Command summary** — Summarizes those commands used to acquire readings.
- **Acquiring readings** — Describes commands to acquire post-processed readings, both trigger and acquire readings, and to perform a single measurement.

Command summary

The signal-oriented measurement commands are used to acquire readings. You can use these high-level instructions to control the measurement process. These commands are summarized in [Table 13-1](#).

Table 13-1

Signal-oriented measurement command summary

Command	Description
:FETCh? :READ? :MEASure?	Requests latest readings. Performs an :INITiate and a :FETCh?. If output is off, turns output on. Performs an :INITiate and a :FETCh?.

Acquiring readings

FETCh?

Description This query command requests the latest post-processed readings stored in the reading buffer. After sending this command and addressing the Model 2520 to talk, the readings are sent to the computer. This command does not affect the instrument setup.

This command does not trigger source and measure operations; it simply requests the last available readings. Note that this command can repeatedly return the same readings. Until there are new readings, this command continues to return the old readings. For example, assume that the Model 2520 performed 20 source and measure operations. The :FETCh? command will request the readings for those 20 source and measure operations. If :FETCh? is sent while performing source and measure operations (ARM annunciator on), it will not be executed until the Model 2520 goes back into idle.

NOTE The :FETCh? command is automatically asserted when the :READ? or :MEASure? command is sent.

The readings that are acquired depend on which data elements are selected ([Section 14](#), “FORMat subsystem,” “Data elements”). Measure readings take priority over source readings, and data from channels not sourced or measured are assigned the NAN (not a number) value of +9.91e37.

NOTE See [Appendix C](#) for a detailed explanation on how data flows through the various operation blocks of the Model 2520. It clarifies the types of readings that are acquired by the various commands to read data.

[[:SENSe[1]]]:DATA[:LATest]?

[[:SENSe2]]:DATA[:LATest]?

[[:SENSe3]]:DATA[:LATest]?

Description These commands work exactly like FETCh?, except that they return only the most recent reading for the specified SENSE channel.

READ?

Description This command is used to trigger and acquire readings. The number of readings depends on how the unit is configured. If the unit is in the fixed mode, this command will trigger and acquire one set of readings. However, if the unit is in the sweep mode, this command will trigger the sweep and then acquire all sweep data points.

When this command is sent, the following commands execute in the order they are presented:

- :INITiate
- :FETCh?

The :INITiate command starts operation by taking the instrument out of idle.

NOTE :READ? is illegal when the :TRIG:SOUR BUS command is in effect. See [Section 8](#), “Triggering,” for details.

After all source and measure operations are completed, the Model 2520 goes back into idle at which time the :FETCh? command is executed. The readings are sent to the computer and displayed when the Model 2520 is addressed to talk.

NOTE The :FORM:ELEM command controls the reading source. See [Section 14](#), “FORMat subsystem,” for details.

MEASure?

Description This command performs essentially the same function as the :READ? command, except that it also turns the source outputs on if they were off.

SCPI Command Reference

- **Reference tables** — Summarizes each SCPI command subsystem.
- **SCPI subsystems** — Provides detailed information on all commands in each SCPI subsystem.

Reference tables

Table 14-1 through Table 14-10 summarize the commands for each SCPI subsystem. The following list includes the SCPI subsystem commands and the table number where each command is summarized.

Summary table	Subsystem	Function(s)
14-1	CALCulate	I/V, V/I, MX + B, and power math functions.
14-2	DISPlay	Display format and messages.
14-3	FORMat	Remote data format.
14-4	OUTPut	Source outputs on-off, interlock status.
14-5	SENSE	Laser diode voltage, photodiode current measurements.
14-6	SOURce	Laser diode current, photodiode source configuration.
14-7	STATus	Instrument status.
14-8	SYSTEM	System presets, error formats.
14-9	TRACe	Sample buffer access.
14-10	TRIGger	Unit triggering control.

General notes:

Brackets ([]) are used to denote optional character sets. These optional characters do not have to be included in the program message. Do not use brackets in the program message.

Angle brackets (< >) are used to indicate parameter type. Do not use angle brackets in the program message.

The Boolean parameter () is used to enable or disable an instrument operation. 1 or ON enables the operation, and 0 or OFF disables the operation.

Upper case characters indicate the short-form version for each command word.

Default Parameter — Listed parameters are both the *RST and :SYSTEM:PRESet defaults, unless noted otherwise. Parameter notes are located at the end of each table.

SCPI — A checkmark (✓) indicates that the command and its parameters are SCPI confirmed. An unmarked command indicates that it is a SCPI command, but does not conform to the SCPI standard set of commands. It is not a recognized command by the SCPI consortium. SCPI confirmed commands that use one or more non-SCPI parameters are explained by notes.

Table 14-1

CALCulate command summary

Command	Description	Default parameter	SCPI
:CALCulate[1]	Path to configure and control laser diode math:		
:DATA	Path to CALC1 data.		
:LATest?	Return only most recent math result.		
:DATA?	Read result of math generated by INIT.		✓
:FORMat <name>	Select math format (MXB{1}, CONDUCTance[1], RESistance[1], or POWER[1].	RES	✓
:FORMat?	Query math format		✓
:KMATH	Configure MX + B parameters.		
:MBFactor <n>	Set B parameter (-9.99999e20 to +9.99999e20).	0	
:MBFactor?	Query B parameter.		
:MMFactor <n>	Set M parameter (-9.99999e20 to +9.99999e20).	1	
:MMFactor?	Query M parameter.		
:MUNits "<string>"	Set MX + B units (1-character ASCII string).	"X"	
:MUNits?	Query M parameter.		
:STATe 	Enable or disable CALC1 math.	OFF	✓
:STATe?	Query state of math.		✓
:CALCulate2	Path to configure and control detector #1 math:		
:DATA	Path to CALC2 data.		
:LATest?	Return only most recent math result.		
:DATA?	Read result of math generated by INIT.		✓
:KMATH	Configure MX + B parameters.		
:MBFactor <n>	Set B parameter (-9.99999e20 to +9.99999e20).	0	
:MBFactor?	Query B parameter.		
:MMFactor <n>	Set M parameter (-9.99999e20 to +9.99999e20).	1	
:MMFactor?	Query M parameter.		
:MUNits "<string>"	Set MX + B units (1-character ASCII string).	"W"	
:MUNits?	Query M parameter.		
:STATe 	Enable or disable CALC2 math.	OFF	✓
:STATe?	Query state of math.		✓

Table 14-1 (continued)

CALCulate command summary

Command	Description	Default parameter	SCPI
:CALCulate3	Path to configure and control detector #2 math:		
:DATA	Path to CALC3 data.		
:LATest?	Return only most recent math result.		
:DATA?	Read result of math generated by INIT.		✓
:KMATH	Configure MX + B parameters.		
:MBFactor <n>	Set B parameter (-9.99999e20 to +9.99999e20).	0	
:MBFactor?	Query B parameter.		
:MMFactor <n>	Set M parameter (-9.99999e20 to +9.99999e20).	1	
:MMFactor?	Query M parameter.		
:MUNits "<string>"	Set MX + B units (1-character ASCII string).	"W"	
:MUNits?	Query M parameter.		
:STATe 	Enable or disable CALC3 math.	OFF	✓
:STATe?	Query state of math.		✓
:CALCulate4	Path to control delta (detector #1 current - detector #2 current):		
:DATA?	Read math result generated by INIT.		✓
:LATest?	Return only most recent math result.		
:STATe 	Enable or disable CALC4 math.	OFF	✓
:STATe?	Query state of math.		

Table 14-2

DISPlay command summary

Command	Description	Default parameter	SCPI
:DISPlay			
:ENABLE 	Turn on or turn off front panel display.	Note 1	✓
:ENABLE?	Query state of display.		
[:WINDow[1]]	Path to locate message to top display line:		✓
:TEXT	Control user test message:	Note 2	✓
:DATA <a>	Define ASCII message "a" (up to 20 characters).		✓
:DATA?	Query text message.		✓
:STATE 	Enable or disable message mode.	Note 3	✓
:STATE?	Query text message state.		✓
:DATA?	Query data on top portion of display.		
:WINDow2	Path to locate message to bottom display line:		
:TEXT	Control user test message:	Note 2	✓
:DATA <a>	Define ASCII message "a" (up to 32 characters).		✓
:DATA?	Query text message.		✓
:STATE 	Enable or disable message mode.	Note 3	✓
:STATE?	Query text message state.		✓
:DATA?	Query data on bottom portion of display.		✓

Notes:

1. *RST and :SYSTem:PRESet has no effect on the display circuitry. Pressing LOCAL or cycling power enables (ON) the display circuit.
2. *RST and :SYSTem:PRESet has no effect on a user-defined message. Pressing LOCAL or cycling power cancels all user-defined messages.
3. *RST and :SYSTem:PRESet has no effect on the state of the message mode. Pressing LOCAL or cycling power disables (OFF) the message mode.

Table 14-3
FORMat command summary

Command	Description	Default parameter	SCPI
:FORMat :SREGister <name>	Select data format for reading status event registers (ASCIi, HEXadecimal, OCTal, or BINary).	ASC	✓
:SREGister? [:DATA] <type>[<,length>] [:DATA]?	Query format for reading status event registers. Specify data format (ASCIi, REAL, 32, or SREal). Query data format.	ASC	✓ ✓
:BORDER <name> :BORDER?	Specify byte order (NORMal or SWAPPed). Query byte order.	Note	✓ ✓
:ELEMENTs <item list>	Specify FETCh? and READ? data elements (CURRent[1], VOLTage[1], CURRent2, VOLTage2, CURRent3, VOLTage3, TIME, and STATus).	VOLT1, CURR2, CURR3	✓
:CALCulate <item list>	Specify CALCulate data elements (CALCulate, TIME, and STATus).	CALC	
:CALCulate? :TRACe <item list>	Query CALCulate data elements. Specify TRACe data elements (VOLTage[1], CURRent2, CURRent3, and TIME).	VOLT1, CURR2, CURR3	
:TRACe? :ELEMENTs? :SOURce4 <name> :SOURce4?	Query TRACe data elements. Query FETCh? and READ? data format elements. Specify SOURce4 data format (ASCIi, HEXadecimal, OCTal, or BIN). Query SOURce4 data format.	ASC	

Note: *RST default is NORMal. :SYST:PRES default is SWAPPed.

Table 14-4
OUTPut command summary

Command	Description	Default parameter	SCPI
:OUTPut[1] [:STATe] [:STATe]?	Path to control all three outputs. Turn all three sources on or off. Query state of sources.	OFF	✓ ✓ ✓
:INTerlock :TRIPped?	Path to interlock status: Interlock tripped?: 1 (yes) or 0 (no).		

Table 14-5

SENSE command summary

Command	Description	Default parameter	SCPI
[[:SENSe[1]]	Sense 1 subsystem to control laser diode voltage measurement:		✓
:VOLTage[:DC]	Path to configure voltage:		✓
:RANGe	Configure measurement range:		✓
[:UPPer] <n>	Select range by specifying the expected voltage reading; 0 to 10.5 (Ranges 5 or 10).	10	✓
[:UPPer]?	Query range.		✓
:POLarity <name>	Select polarity. Name = POSitive or NEGative.	POS	
:POLarity?	Query polarity.		
:PROT:TRIPped?	Query if voltage compliance limit is exceeded (1 = yes; 0 = no).		✓
:AVERage	Path to configure digital filter: *	10	✓
:COUNT <n>	Specify filter count; 1 to 100.		✓
:COUNT?	Query filter count.	OFF	✓
[:STATe] 	Enable or disable digital filter.		✓
[:STATe]?	Query state of digital filter.		
:DATA[:LATest]?	Query latest reading only when trigger model is in IDLE.		
:SENSe2	Sense 2 subsystem to control detector #1 current measurement:		✓
:CURRent[:DC]	Path to configure current:		✓
:RANGe	Configure measurement range:		✓
[:UPPer] <n>	Select range by specifying the expected current reading; 0 to 0.105 (Ranges 0.01, 0.02, 0.05, 0.1).	0.1	✓
[:UPPer]?	Query range.		✓
:POLarity <name>	Select polarity. Name = POSitive or NEGative.	POS	
:POLarity?	Query polarity.		
:AVERage	Path to configure digital filter:*		✓
:COUNT <n>	Specify filter count; 1 to 100.	10	✓
:COUNT?	Query filter count.		✓
[:STATe] 	Enable or disable digital filter.	OFF	✓
[:STATe]?	Query state of digital filter.		✓
:SWEep	Path to sweep abort commands:		
:CABort			
[:LEVel]<n>	Set detector #1 current level for sweep abort (0 to 0.105).	0.105	
[:LEVel]?	Query detector #1 sweep abort current threshold.		
:STATE	Enable or disable detector #1 sweep abort function.	OFF	
:STATE?	Query state of detector #1 sweep abort function.		
:DATA[:LATest]?	Query latest reading only when trigger model is in IDLE.		

* :AVERage filter commands are global and affect all three measurements (:SENS1, :SENS2, and :SENS3) simultaneously.

Table 14-5 (continued)
SENSe command summary

Command	Description	Default parameter	SCPI
:SENSe3	Sense 3 subsystem to control detector #2 current measurement:		✓
:CURRent[:DC]	Path to configure current:		✓
:RANGe	Configure measurement range:		✓
[:UPPer] <n>	Select range by specifying the expected current reading; 0 to 0.105 (Ranges 0.01, 0.02, 0.05, 0.1).	0.1	✓
[:UPPer]?	Query range.		✓
:POLarity <name>	Select polarity. Name = POSitive or NEGative.	POS	
:POLarity?	Query polarity.		
:AVERage	Path to configure digital filter:*		✓
:COUNT <n>	Specify filter count; 1 to 100.	10	✓
:COUNT?	Query filter count.		✓
[:STATe] 	Enable or disable digital filter.	OFF	✓
[:STATe]?	Query state of digital filter.		✓
:SWEep	Path to sweep abort commands:		
:CABort			
[:LEVel]<n>	Set detector #2 current level for sweep abort (0 to 0.105).	0.105	
[:LEVel]?	Query detector #2 sweep abort current threshold.		
:STATe	Enable or disable detector #2 sweep abort function.	OFF	
:STATe?	Query state of detector #2 sweep abort function.		
:DATA[:LATest]?	Query latest reading only when trigger model is in IDLE.		

* :AVERage filter commands are global and affect all three measurements (:SENS1, :SENS2, and :SENS3) simultaneously.

Table 14-6

SOURce command summary

Command	Description	Default parameter	SCPI
:SOURce[1]	Path to control laser diode current source:		✓
:CLEar[:IMMediate]	Turn all three sources off.		
:CURRent	Path to configure current:		✓
:MODE <name>	Select mode (FIXed, SWEEp, or LIST).	FIX	✓
:MODE?	Query mode.		✓
:RANGe <n>	Select fixed range; 0 to 5.0 (Range = 0.5 or 5).	0.5	✓
:RANGe?	Query range setting.		✓
[:LEVel]	Set source level (in amps):		✓
[:IMMediate]	Set specified current level immediately:		✓
[:AMPLitude] <n>	Specify current level for FIXed mode; 0 to 5.	0	✓
[:AMPLitude]?	Query current level.		✓
:LOW <n>	Specify low current pulse level; 0 to 0.015, 500mA range; 0 to 0.15, 5A range.	0	
:LOW?	Query low current pulse level.		
:POLarity <name>	Specify polarity (POSitive or NEGative).	POS	
:POLarity?	Query polarity.		
:STARt <n>	Specify start level for I-sweep; 0 to 5.0.	0	✓
:STARt?	Query start level for current sweep.		✓
:STOP <n>	Specify stop level for I-sweep; 0 to 5.0.	0	✓
:STOP?	Query stop level for current sweep.		✓
:STEP <n>	Specify step value for I-sweep; 0 to 5.0.	0	
:STEP?	Query step value for current sweep.		✓
:SPAN <n>	Specify span; 0 to 5.0.	0	✓
:SPAN?	Query span.		✓
:CENTer <n>	Specify center point; 0 to 5.0.	0	✓
:CENTer?	Query center point.		✓
:FUNction			
[:SHAPE] <name>	Select source shape (PULSe or DC).	PULS	✓
[:SHAPE]?	Query source shape.		✓
:PULSe	Path to control pulse generation for FIXed and SWEEp.		
:DELay <n>	Set delay between pulses; 20e-6 to 0.5. ¹	10e-3	✓
:DELay?	Query delay between pulses.		✓
:WIDTh <n>	Set pulse width; 500e-9 to 5e-3. ¹	10e-6	✓
:WIDTh?	Query pulse width.		✓
:TRANsition	Control pulse leading edge time.		
:STATe 	Enable or disable transition control.	OFF	✓
:STATe?	Query transition control state.		✓

¹ Minimum and default pulse delay and width values depend on pulse duty cycle. See "Duty cycle" in Section 5.

Table 14-6 (continued)

SOURce command summary

Command	Description	Default parameter	SCPI
:SOURce[1]	Path to control laser diode current source (continued):		
:VOLTage	Path to set compliance level.		
:PROTection			
[:LEVel] <NRf>	Set voltage limit; 3 to 10.5.	10	
[:LEVel]?	Query voltage limit.		
:SWEep	Configure staircase sweep mode:		
:SPACing <name>	Select sweep spacing type (LINEar or LOGarithmic).	LIN	✓
:SPACing?	Query sweep spacing.		✓
:POINts <n>	Specify number of sweep points (2 to 1000).	1000	
:POINts?	Query number of points in sweep.		
:DIRection <name>	Sweep from start to stop (UP) or from stop to start (DOWN).	UP	
:DIRection?	Query sweep direction.		
:LIST	Configure list sweep mode:		
:CURRent <NRf>	Create list of up to 100 source values; 0 to 5.0.	Note 1	
:APPend <NRf>	Add up to 100 source values to end of list.	Note 1	
:POINts?	Query number of source values in list.	Note 2	
:CURRent?	Query all points in source list.		
:WIDTh <NRf>	Create list of pulse width values; 500e-9 to 5e-3. ³	Note 1	
:APPend <NRf>	Add up to 100 pulse width values to end of list.	Note 1	
:POINts?	Query number of pulse width values in list.	Note 2	
:WIDTh?	Query all points in pulse width list.		
:DELay <NRf>	Create list of pulse delay values; 20e-6 to 0.5. ³	Note 1	
:APPend <NRf>	Add up to 100 pulse delay values to end of list.	Note 1	
:POINts?	Query number of pulse delay values in list.	Note 2	
:DELay?	Query all points in pulse delay list.		
:DIRection <name>	Specify direction of list sweep (UP or DOWN).	UP	
:DIRection?	Query direction of list sweep.		

Notes:

1. Not affected by *RST or :SYSTem:PRESet.
2. 1 on power-up; otherwise not affected by *RST or :SYSTem:PRESet.
3. Minimum and default pulse delay and width values depend on pulse duty cycle. See [Section 5, "Duty cycle."](#) If delay and width are not programmed, default values of 1.5ms (delay) and 500ns (width) will be used and queries will return 0.

Table 14-6 (continued)

SOURCE command summary

Command	Description	Default parameter	SCPI
:SOURCE2	Path to control detector #1 voltage bias source:		✓
:VOLTage			✓
[:LEVel]	Set source level (in volts):		✓
[:IMMediate]	Set specified voltage level immediately:		✓
[:AMPLitude] <n>	Specify voltage level; -20 to 20.	0	✓
[:AMPLitude]?	Query voltage level.		✓
:SOURCE3	Path to control detector #2 voltage bias source:		✓
:VOLTage			✓
[:LEVel]	Set source level (in volts):		✓
[:IMMediate]	Set specified voltage level immediately:		✓
[:AMPLitude] <n>	Specify voltage level; -20 to 20.	0	✓
[:AMPLitude]?	Query voltage level.		✓
:SOURCE4	Path to control digital output lines:		
:BSIZE <n>	Set Digital I/O bit size (4 or 16). ¹	No effect	
:BSIZE?	Query Digital I/O bit size.		
:TTL			
[:LEVel] <NRf> <NDN>	Specify digital output pattern (0 to 15). ²	15 ³	
[:LEVel]?	Query pattern on digital output port.		

¹16-bit size available only with 2499-DIGIO option.²0 to 65535 with 2499-DIGIO option.³65535 with 2499-DIGIO option.

Table 14-7
STATus command summary

Command	Description	Default parameter	SCPI
:STATus		Note 1	✓
:MEASurement	Control measurement event registers:		
[:EVENT]?	Read the event register. ⁶	Note 2	✓
:ENABle <NDN> or <NRf>	Program the enable register.	Note 3	✓
:ENABle?	Read the enable register. ⁶		✓
:CONDition?	Read the condition register. ⁶		✓
:OPERation	Control operation status registers:		✓
[:EVENT]?	Read the event register. ⁶	Note 2	✓
:ENABle <NDN> or <NRf>	Program the enable register.	Note 3	✓
:ENABle?	Read the enable register. ⁶		✓
:CONDition?	Read the condition register. ⁶		✓
:QUESTionable	Control questionable status registers:		✓
[:EVENT]?	Read the event register. ⁶	Note 2	✓
:ENABle <NDN> or <NRf>	Program the enable register.	Note 3	✓
:ENABle?	Read the enable register. ⁶		✓
:CONDition?	Read the condition register. ⁶		✓
:PRESet	Return status registers to default states.		✓
:QUEue	Path to access error queue:		
[:NEXT]?	Read the most recent error message.	Note 4	✓
:ENABle <list>	Specify error and status messages for error queue.	Note 5	✓
:ENABle?	Read the enabled messages.		✓
:DISable <list>	Specify messages not to be placed in error queue.	Note 5	
:DISable?	Read the disabled messages.		
:CLear	Clears all messages from error queue.		

Notes:

1. Commands in this subsystem are not affected by *RST and :SYSTem:PRESet. The effects of cycling power, *CLS and :STATus:PRESet, are explained by the following notes.
2. Event Registers — Power-up and *CLS clears all bits.:STATus:PRESet has no effect.
3. Enable Registers — Power-up and :STATus:PRESet clears all bits. *CLS has no effect. Accepts the SCPI 1995.0 mandated (non-decimal numeric) format (#H, #Q, or #B).
4. Error Queue — Power-up and *CLS clears all bits of the registers.
5. Error Queue Messages — Power-up clears list of messages. *CLS and :STATus:PRESet have no effect.
6. Register Query Commands — The format for the response messages (ASCII, hexadecimal, octal, or binary) depend on which data format is presently selected. See the :FORMat:SREGister command.

Table 14-8

SYSTEM command summary

Command	Description	Default parameter	SCPI
:SYSTem			
:PRESet	Return to :SYSTem:PRESet defaults.		✓
:POSetup <name>	Select power-on setup (RST, PRESet or SAV 0-4).		
:POSetup?	Query power-on setup.		
:VERSion?	Query revision level of SCPI.		✓
:ERRor	Path to read messages in error queue. ¹		✓
[:NEXT]?	Return and clear oldest error (code and message).		
:ALL?	Return and clear all errors (codes and messages).		
:COUNt?	Return the number of errors.		
:CODE	Path to return error code numbers only:		
[:NEXT]?	Return and clear oldest error (code only).		
:ALL?	Return and clear all errors (codes only).		
:CLEar	Clears messages from error queue.		
:KEY <n>	Simulate key-press (1 to 31).		✓
:KEY?	Query the last “pressed” key.		✓
:TIME	Timestamp:		
:RESet	Reset timestamp to zero seconds.		
:LOCal	Take unit out of remote and cancel local lockout (RS-232).		
:REMOte	Put unit in remote (RS-232).		
:RWLock	Enable local lockout (RS-232).		

¹Clearing Error Queue — Power-up and *CLS clears the error queue. *RST, :SYSTem:PRESet, and :STATus:PRESet have no effect.

Table 14-9

TRACe command summary

Command	Description	Default parameter	SCPI
:TRACel:DATA	Access and control sample buffer:		✓
:DATA?	Returns raw samples.		✓
:VALue? [NRf]	Returns specified sample after start of pulse.		
:POINts <n>	Sets number of samples to return for :TRAC:DATA? query (1 to 3000).	100	✓
:POINts?	Queries number of samples to return.		✓

Table 14-10
TRIGger command summary

Command	Description	Default parameter	SCPI
:INITiate[:IMMEDIATE]	Initiate source and measure cycle(s).		✓
:ABORt	Reset trigger system. Goes to idle state.		✓
:TRIGger	Path to program Trigger Layer:		✓
[:SEQuence[1]]			✓
[:LAYer[1]]			✓
:COUNT <n>	Specify trigger count (1 to 5000 or INFinite).	1	✓
:COUNT?	Query trigger count (INFinite = +9.9e37).		✓
:SOURce <name>	Specify control source (IMMEDIATE, TIMer, MANual, BUS, TLINK, NSTest, PSTest, BSTest).	IMM	✓
:SOURce?	Query control source.		✓
:TIMer <n>	Set timer interval in seconds (0 to 99999.99).	0.1	✓
:TIMer?	Query timer interval.		✓
[:TCONfigure]			✓
[:ASYNchronous]	Configure trigger lines and output trigger:		✓
:ILINe <n>	Select input trigger line (1, 2, 3, 4, 5, or 6).	1	
:ILINe?	Query input trigger line.		
:OLINe <n>	Select output trigger line (1, 2, 3, 4, 5, or 6).	2	
:OLINe?	Query output trigger line.		
:OUTPut <name>	Output trigger (TRIGger or NONE).	NONE	
:OUTPut?	Query output trigger status.		

Calculate subsystems

There are a total of four CALCulate subsystems:

- CALC1: Laser diode math (I/V, V/I, $V \times I$, or $MX + B$).
- CALC2: Detector #1 math (MX + B only).
- CALC3: Detector #2 math (MX + B only).
- CALC4: Detector #1 current - detector #2 current.

The commands in these subsystems are summarized in [Table 14-1](#).

NOTE See [Appendix C](#) for a detailed explanation on how data flows through the various CALC operation blocks of the Model 2520. It clarifies the type of readings that are acquired by the various commands to read data.

Query	:MMFactor?	Query M (slope) value for MX + B
Description	These commands program the M (slope) value for the MX + B math function. Use CALC1 for the laser diode, CALC2 for detector #1, and CALC3 for detector #2.	

UNITs <name>

:CALCulate[1]:KMATH:MUNits <name>	Specify units for laser diode MX + B
:CALCulate2:KMATH:MUNits <name>	Specify units for detector #1 MX + B
:CALCulate3:KMATH:MUNits <name>	Specify units for detector #2 MX + B

Parameters <name> = One ASCII character enclosed in single or double quotes

Query :MUNits? Query units for MX + B

Description These commands are used to specify the units suffix name for the MX + B math function for CALC1 through CALC3. Use one upper- or lower-case ASCII character for the units suffix name (no numbers, spaces, dashes, etc.).

Enable and read math function result

STATe

:CALCulate[1]:STATe 	Control laser diode math function
:CALCulate2:STATe 	Control detector #1 math function
:CALCulate3:STATe 	Control detector #2 math function
:CALCulate4:STATe 	Control delta (detector #1 - detector #2) math function

Parameters = 0 or OFF Disable CALC1 to CALC4 math function.

Parameters 1 or ON Enable CALC1 to CALC4 math function.

Query :STATe? Query state (on or off) of CALC1 to CALC4

Description These commands are used to enable or disable the CALC1, CALC2, CALC3, and CALC4 math function for the laser diode, detector #1, and detector #2 respectively. When enabled, the selected math function calculation will be performed when the Model 2520 is triggered to perform the programmed source and measure operations (use INIT).

After the Model 2520 returns to idle, you can read the result of the selected math function using the :CALC1:DATA?, :CALC2:DATA?, :CALC3:DATA?, or CALC4:DATA? query. (See below). When disabled, the :CALC1:DATA?, :CALC2:DATA?, :CALC3:DATA?, and :CALC4:DATA? queries will return the NAN (not a number) value of +9.91e37.

DATA?

:CALCulate[1]:DATA?	Read laser diode math (CALC1) result
:CALCulate2:DATA?	Read detector #1 math (CALC2) result
:CALCulate3:DATA?	Read detector #2 math (CALC3) result
:CALCulate4:DATA?	Read delta math (CALC4) result

Description These query commands are used to read the result of the CALC1, CALC2, CALC3, or CALC4 calculation. The largest valid calculation result can be $\pm 9.9e37$, which (defined by SCPI) is infinity.

An invalid NAN (not a number) result of +9.91e37 indicates that CALC1, CALC2, CALC3, or CALC4 is disabled or that a division by zero error has occurred. See “[STATE](#),” page 14-16.

LATest?

:CALCulate[1]:DATA:LATest?	Read latest CALC1 result
:CALCulate2:DATA:LATest?	Read latest CALC2 result
:CALCulate3:DATA:LATest?	Read latest CALC3 result
:CALCulate4:DATA:LATest?	Read latest CALC4 result

Description These commands work exactly like CALC1:DATA?, CALC2:DATA?, CALC3:DATA?, and CALC4:DATA? except that they return only the latest CALC1, CALC2, CALC3, or CALC4 result.

DISPlay subsystem

The display subsystem controls the display of the Model 2520 and is summarized in [Table 14-2](#).

Control display

**ENABLE **

:DISPlay:ENABLE 	Control display circuitry
---------------------	---------------------------

Parameters	 =	0 or OFF	Disable display circuitry
		1 or ON	Enable display circuitry

Query	:ENABLE?	Query state of display
--------------	----------	------------------------

Description This command is used to enable and disable the front panel display circuitry. When disabled, the instrument operates at a higher speed. While disabled, the display is frozen with the following message:

FRONT PANEL DISABLED

Press LOCAL to resume.

As reported by the message, all front panel controls (except LOCAL and OUTPUT OFF) are disabled. Normal display operation can be resumed by using the :ENABLE command to enable the display or by putting the Model 2520 into local.

ATTRIBUTES?

:DISPlay[:WINDow[1]]:ATTRIBUTES?	Query attributes; top display
:DISPlay:WINDow2:ATTRIBUTES?	Query attributes; bottom display

Description These query commands are used to determine which characters on the display are blinking and which are not. The response message provides that status of each character position for the specified display. The primary display consists of 20 characters and the secondary display consists of 32 characters.

1 = Character is blinking
0 = Character is not blinking

Read display**DATA?**

:DISPlay[:WINDow[1]]:DATA?	Read top display
:DISPlay:WINDow2:DATA?	Read bottom display

Description These query commands are used to read what is currently being displayed on the top and bottom displays. After sending one of these commands and addressing the Model 2520 to talk, the displayed data (message or reading) will be sent to the computer.

Define :TEXT messages**DATA <a>**

:DISPlay[:WINDow[1]]:TEXT:DATA <a>	Define message; top display
:DISPlay:WINDow2:TEXT:DATA <a>	Define message; bottom display

Parameters <a> = ASCII characters for message

Types: String 'aa...a' or "aa...a"
Indefinite Block #0aa...a
Definite Block #XYaa...a

where Y = number of characters in message:
Up to 20 for top display
Up to 32 for bottom display
X = number of digits that make up Y (1 or 2)

Query :DATA? Query the defined text message

Description These commands define text messages for the display. A message can be as long as 20 characters for the top display, and up to 32 characters for the bottom display. A space is counted as a character. Excess message characters result in an error.

Description This command is used to select the data format for transferring readings over the bus. Only the ASCII format is allowed over the RS-232 interface. This command only affects the output of READ?, FETCh?, MEASure?, TRACe:DATA?, CALCx:DATA? over the GPIB. All other queries are returned in the ASCII format.

NOTE Regardless of which data format for output strings is selected, the Model 2520 will only respond to input commands using the ASCII format.

ASCII format

The ASCII data format is in a direct readable form for the operator. Most BASIC languages easily convert ASCII mantissa and exponent to other formats. However, some speed is compromised to accommodate the conversion. Figure 14-1 shows an example ASCII string that includes current, voltage, time, and status data elements. Data elements not specified by the :ELEMents command are simply not included in the string. See “ELEMents <item list>,” page 14-22.

Figure 14-1
ASCII data format

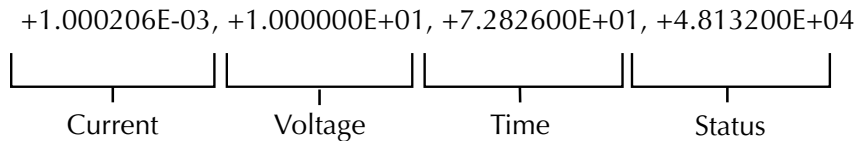

IEEE-754 single precision format

REAL, 32, or SREal will select the binary IEEE-754 single precision data format. Figure 14-2 shows the normal byte order format for each data element. For example, if three valid elements are specified, the data string for each reading conversion is made up of three 4-byte data blocks. Note that the data string for each reading conversion is preceded by a 2-byte header that is the binary equivalent of an ASCII # sign and 0. Figure 14-2 does not show the byte for the terminator that is attached to the end of each data string.

Figure 14-2
IEEE-754 single precision data format (32 data bits)

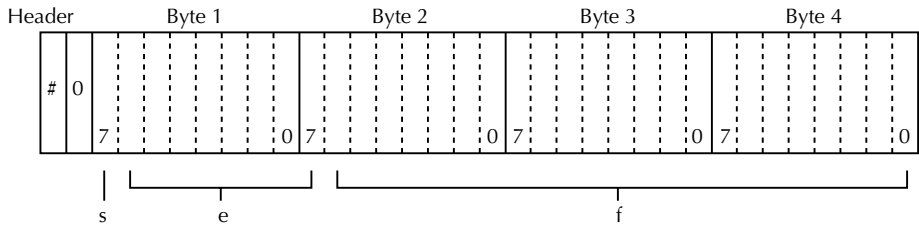

s = sign bit (0 = positive, 1 = negative)
 e = exponent bits (8)
 f = fraction bits (23)

Normal byte order shown. For swapped byte order, bytes sent in reverse order: Header, Byte 4, Byte 3, Byte 2, Byte 1.

The header and terminator are sent only once for each READ?

During binary transfers, never un-talk the Model 2520 until after the data is read (input) to the computer. Also, to avoid erratic operation, the readings of the data string (and terminator) should be acquired in one piece. The header (#0) can be read separately before the rest of the string.

NOTE *The Model 2520 terminates the binary data string with LF + EOI. If your program is set to terminate on CR and/or LF, data transfer may terminate prematurely because one or more data bytes has a CR or LF value. To avoid the problem, set your computer program to terminate on EOI only.*

The number of bytes to be transferred can be calculated as follows:

$$\text{Bytes} = 2 + (\text{Rdgs} \times 4) + 1$$

where 2 is the number of bytes for the header (#0).

Rdgs is the product of the number of selected data elements, arm count, and trigger count.

4 is the number of bytes for each reading.

is the byte for the terminator.

For example, assume the Model 2520 is configured to perform 10 source and measure operations and send the 10 current measurements to the computer using the binary format.

$$\text{Bytes} = 2 + (10 \times 4) + 1 = 43$$

Data elements

ELEMents <item list>

:FORMat:ELEMents [SENSe] <item list> Specify data elements for data string

Parameters	<item list> = CURRent[1]	Includes laser diode source value
	CURRent2	Includes detector #1 current reading
	CURRent3	Includes detector #2 current reading
	VOLTage[1]	Includes laser diode voltage reading
	VOLTage2	Includes detector #1 source value
	VOLTage3	Includes detector #2 source value
	TIME	Includes timestamp
	STATus	Includes status information

NOTE Each item in the list must be separated by a comma (i.e., VOLT1, CURR2, TIME).

Query :ELEMents? Query elements in data string

Description This command is used to specify the elements to be included in the data string in response to the following queries:

:FETCh?

:READ?

:MEASure?

You can specify from one to all eight elements. Each element in the list must be separated by a comma (.). These elements (shown in [Figure 14-1](#)) are explained as follows:

NOTE An overflow reading reads as +9.9E37.

CURRent[1] — This element provides the laser diode current source value.

CURRent2 — This element provides the detector #1 current reading. If no current reading is available, the NAN (not a number) value of +9.91e37 is used.

CURRent3 — This element provides the detector #2 current reading. If no current reading is available, the NAN (not a number) value of +9.91e37 is used.

VOLTage[1] — This element provides the laser diode voltage reading. If voltage reading is available, the NAN (not a number) value of +9.91e37 is used.

VOLTage2 — This element provides the detector #1 voltage source value.

VOLTage3 — This element provides the detector #2 voltage source value.

TIME — A timestamp is available to reference each group of readings to a point in time. The relative timestamp operates as a timer that starts at zero seconds when the instrument is turned on or when the relative timestamp is reset (:SYSTem:TIME:RESet). The timestamp for each reading sent over the bus is referenced, in seconds, to the start time. After 99,999.999 seconds, the timer resets to zero and starts over. The timer value updates for each pass through the Trigger Event Detector (see [Figure 8-6](#)). Therefore, all points in a single sweep will have the same time value.

STATus — A status word is available to provide status information concerning Model 2520 operation. The 16-bit status word is sent in a decimal form and must be converted by the user to the binary equivalent to determine the state of each bit in the word. For example, if the status value is 17, the binary equivalent is 000000000010001. Bits 0 and 4 are set.

The significance of each status bit is explained as follows:

Bit 0 (OFLO1) — Set to 1 if the laser diode voltage measurement was made while in over-flow. Cleared to 0 otherwise.

Bit 1 (OFLO2) — Set to 1 if the detector #1 current measurement was made while in over-flow. Cleared to 0 otherwise.

Bit 2 (OFLO3) — Set to 1 if the detector #2 current measurement was made while in over-flow. Cleared to 0 otherwise.

Bit 3 (COMPL) — Set to 1 if the laser diode current source is in voltage compliance (limit). Cleared to 0 otherwise.

Bit 4 (FILT) — Set to 1 if any measurement was made with the averaging filter on. Cleared to 0 otherwise.

Calculate data elements

CALCulate <item list>

:FORMat:ELEMents:CALCulate <item list>

Specify CALC data string elements

Parameters	<item list> = CALCulate	Includes CALC data element
	TIME	Includes timestamp
	STATus	Includes status information

NOTE Each item in the list must be separated by a comma (i.e., CALC, TIME).

Query :CALCulate? Query elements in CALC data string

Description This command is used to specify the data elements returned by the CALCn:DATA? and CALCn:DATA:LATest? queries. You can specify from one to all three elements. Each element in the list must be separated by a comma (.). These elements are explained as follows:

NOTE An overflow reading reads as +9.9E37.

CALCulate — This element provides the CALCulate result value.

TIME — This element returns the timestamp (see “CALCulate <item list>,” page 14-23, for description).

STATus — This element returns the 16-bit status word (see “CALCulate <item list>,” page 14-23, for description).

TRACe data elements

TRACe <item list>

:FORMat:ELEMents:TRACe <item list>

Specify TRACe data string elements

Parameters	<item list> = VOLTage[1]	Includes laser diode voltage
	CURRent2	Includes detector #1 current reading
	CURRent3	Includes detector #2 current reading
	TIME	Includes timestamp

NOTE Each item in the list must be separated by a comma (i.e., VOLT1, CURR2, TIME).

Query :TRACe? Query TRACe data string elements

Description This command is used to specify the elements to be included in the data string in response to the :TRACe:DATA? and :TRACe:DATA:VALue? queries.

You can specify from one to all three elements. Each element in the list must be separated by a comma (.). These elements are explained as follows:

NOTE An overflow reading reads as +9.9E37.

VOLTage[1] — This element provides the laser diode voltage measurement value. If no voltage reading is available, the NAN (not a number) value of +9.91e37 is used.

CURRent2 — This element provides the detector #1 current reading. If no current reading is available, the NAN (not a number) value of +9.91e37 is used.

CURRent3 — This element provides the detector #2 current reading. If no current reading is available, the NAN (not a number) value of +9.91e37 is used.

TIME — This element returns the timestamp value. The first reading taken during the pulse will be given a TIME value of 0. The TIME value is then incremented by 100ns for each successive reading.

NOTE *In the pulse mode, the current source pulse will not necessarily start at the first reading and may be delayed by up to five readings (500ns). To determine when the pulse actually occurs, you must look at the measurement data.*

SOURce4 <name>

:FORMat:SOURce4 <name>

Set SOUR4:TTL response format

Parameters	<name> =	ASCIi	ASCII format
		HEXadecimal	Hexadecimal format
		OCTal	Octal format
		BINary	Binary format

Query :SOURce4? Query response format

Description This command controls the response format for the SOUR4:TTL query in a manner similar to formats set by the FORM:SREG command. See “SOURce subsystem,” page 14-32, for details.

Byte order

BORDer <name>

:FORMat:BORDer <name>

Specify binary byte order

Parameters	<name> =	NORMal	Normal byte order for binary formats
		SWAPped	Reverse byte order for binary formats

Query :BORDer? Query byte order

Description This command is used to control the byte order for the IEEE-754 binary formats. For normal byte order, the data format for each element is sent as follows:

Byte 1 Byte 2 Byte 3 Byte 4 (Single precision)

For reverse byte order, the data format for each element is sent as follows:

Byte 4 Byte 3 Byte 2 Byte 1 (Single precision)

The “#0” header is not affected by this command. The header is always sent at the beginning of the data string for each measurement conversion.

The ASCII data format can only be sent in the normal byte order. The SWAPPed selection is simply ignored when the ASCII format is selected.

NOTE The SWAPPed byte order must be used when transmitting binary data to any IBM PC compatible computer.

Status register format

SREGister <name>

:FORMat:SREGister <name>

Set data format for reading status registers

Parameters	<name> =	ASCii	Decimal format
		Hexadecimal	Hexadecimal format
		OCTal	Octal format
		BINary	Binary format

Query :SREGister? Query format for reading status registers

Description Query commands are used to read the contents of the status event registers. This command is used to set the response message format for those query commands.

When a status register is queried, the response message is a value that indicates which bits in the register are set. For example, if bits B5, B4, B2, B1, and B0 of a register are set (110111), the following values will be returned for the selected data format:

ASCii	55	(decimal value)
Hexadecimal	#H37	(hexadecimal value)
OCTal	#Q67	(octal value)
BINary	#B110111	(binary value)

See [Section 11](#) and “[STATus subsystem](#),” page 14-49, for more information.

Select laser diode voltage measurement range

[:UPPer] <n>

`:SENSe[1]:VOLTage[:DC]:RANGe[:UPPer] <n>|UPIDOWN` Select laser diode voltage range

Parameters	<code><n></code>	=	0 to 10.5	Expected reading in volts
			DEFault	10
			MINimum	0
			MAXimum	10.5
			UP	Select next higher measurement range
			DOWN	Select next lower measurement range

Query	<code>:RANGe?</code>	Query measurement range
	<code>:RANGe? DEFault</code>	Query *RST default range
	<code>:RANGe? MINimum</code>	Query lowest range (returns 0)
	<code>:RANGe? MAXimum</code>	Query highest range

Description This command is used to select the measurement range for the laser diode voltage measurement. The range is selected by specifying the expected reading. The instrument will then go to the most sensitive reading that will accommodate that reading. For example, if you expect a reading of approximately 7V then simply let `<n> = 7` in order to select the 10V range.

You can also use the UP and DOWN parameters to select range. Each time UP or DOWN is sent, the next higher or lower measurement range is selected. When on the maximum range, sending UP is a No-Op (no operation). When on the lowest range, sending DOWN is a NO-Op.

Select detector current measurement range

[:UPPer] <n>

`:SENSe2:CURRent[:DC]:RANGe[:UPPer] <n>|UPIDOWN` Select detector #1 current range
`:SENSe3:CURRent[:DC]:RANGe[:UPPer] <n>|UPIDOWN` Select detector #2 current range

Parameters	<code><n></code>	=	0 to 0.105	Expected reading in amps
			DEFault	0.1
			MINimum	0
			MAXimum	0.105
			UP	Select next higher measurement range
			DOWN	Select next lower measurement range

Query	<code>:RANGe?</code>	Query measurement range
	<code>:RANGe? DEFault</code>	Query *RST default range
	<code>:RANGe? MINimum</code>	Query lowest range (returns 0)
	<code>:RANGe? MAXimum</code>	Query highest range

Description These commands are used to select the current measurement range for detector #1 and detector #2. The range is selected by specifying the expected reading. The instrument will then go to the most sensitive reading that will accommodate that reading. For example, if you expect a reading of approximately 60mA, then simply let $\langle n \rangle = 0.06$ (or $6e-2$) in order to select the 100mA range.

You can also use the UP and DOWN parameters to select range. Each time UP or DOWN is sent, the next higher or lower measurement range is selected. When on the maximum range, sending UP is a No-Op (no operation). When on the lowest range, sending DOWN is a NO-Op.

Select polarity

POLarity <name>

[:SENSe[1]]:VOLTage:POLarity <name>	Set laser diode measurement polarity
:SENSe2:CURRent:POLarity <name>	Set detector #1 measurement polarity
:SENSe3:CURRent:POLarity <name>	Set detector #2 measurement polarity

Parameters	<name> =	POSitive	Positive polarity
		NEGative	Negative polarity

Query	:POLarity?	Query measurement polarity
--------------	------------	----------------------------

Description These commands are used to select the measurement polarity for laser diode voltage measurements and detector current measurements. POSitive selects normal polarity, while NEGative selects reversed polarity.

See [Section 3, “Configuring measurements”](#) for more information on polarity.

Query voltage limit

TRIPped?

[:SENSe[1]]:VOLTage:PROT:TRIPped?	Query if voltage limit reached
-----------------------------------	--------------------------------

Query	:TRIPped?	Query if voltage limit reached
--------------	-----------	--------------------------------

Description This query command is used to determine if the laser diode voltage measurement compliance limit has been reached. A returned value of 1 indicates that the voltage limit has been reached (see [“PROTection\[:LEVel\] <NRf>,” page 14-35](#)). A returned value of 0 indicates that the limit has not been reached.

**[:STATe] **

[:SENSe[1]]:AVERAge[:STATe] Enable/disable digital filter
 :SENSe2:AVERAge[:STATe] Enable/disable digital filter
 :SENSe3:AVERAge[:STATe] Enable/disable digital filter

Parameters = 0 or OFF Disable digital filter
 1 or ON Enable digital filter

Query [:STATe]? Query state of average digital filter

Description These commands are used to enable or disable the average digital filter. When enabled voltage and current readings are filtered according to how many readings are averaged (see “COUNT <n>,” page 14-30). When disabled, the digital filter stage is bypassed.

Abort sweep**:CABort[:LEVel] <n>**

:SENSe2:SWEEp:CABort[:LEVel] <n> Set detector #1 sweep abort current
 :SENSe3:SWEEp:CABort[:LEVel] <n> Set detector #2 sweep abort current

Parameters <n> = 0 to 0.105 Sweep abort current in amps
 DEFault 0.105
 MINimum 0
 MAXimum 0.105

Query :CABort[:LEVel]? Query sweep abort current threshold

Description These commands provide means to set a maximum detector current for detector #1 or detector #2 that will cause a sweep to be aborted if the corresponding detector current threshold is reached. Sweep abort must be enabled with the :STATe command (see below).

The Sweep Aborted bit (Bit 7) in the Measurement Event Register will be set if the sweep aborts early because of reaching the maximum detector current threshold for a particular channel. The Model 2520 can be programmed to generate an SRQ under these conditions. See Section 11 for register and SRQ details.

**:CABort:STATe **

:SENSe2:SWEEp:CABort:STATe Enable/disable detector #1 sweep abort
 :SENSe3:SWEEp:CABort:STATe Enable/disable detector #2 sweep abort

Parameters = 0 or OFF Disable sweep abort
 1 or ON Enable sweep abort

Query :STATe? Query sweep abort state

Description These commands enable or disable sweep abort when the programmed current threshold is reached (see [:LEVel] above).

SOURce subsystem

This subsystem is used to configure and control the laser diode current source, the two detector voltage bias sources, and to set the logic level (high or low) of each digital output line. The commands for this subsystem are summarized in [Table 14-6](#).

SOURce[1]

Use the following commands to configure and control the laser diode current source.

NOTE See [Section 5](#) for pulse and sweep waveform definitions.

Control source outputs on-off

[:IMMEDIATE]

:SOURce[1]:CLEar[:IMMEDIATE] Turn source outputs off

Description This command is used to turn off all three sources and performs the same function as the :OUTPut OFF command.

NOTE The *SOUR1:CLEar* command is global and turns off all three source outputs.

Select sourcing mode

MODE <name>

:SOURce[1]:CURRent:MODE <name> Select laser diode sourcing mode

Parameters	<name> =	FIXed	Select fixed sourcing mode
		LIST	Select list sourcing mode
		SWEep	Select sweep sourcing mode

Query :MODE? Query sourcing mode

Description This command is used to select the sourcing mode for the laser diode current source. The three modes are explained as follows:

FIXed — In this sourcing mode, the source will output a fixed level. Use the :RANGe and :AMPLitude commands to specify the fixed source level. See “[Select source range](#),” page 14-33, and “[Set amplitudes](#),” page 14-34.

LIST — In this mode, the source will output current pulses that are specified in a list. See “[Configure list](#),” page 14-41, for commands to define and control the execution of the list.

SWEep — In this mode, the source will perform a staircase current sweep. See “[Configure sweeps](#),” page 14-37, for commands to define the sweep.

NOTE The sourcing mode will default to *FIXed* whenever the Model 2520 goes to the local state.

Select source function

FUNCTION[:SHAPE] <name>

:SOURce[1]:FUNCTION[:SHAPE] <name> Select laser diode source function

Parameters <name> = DC Select DC source function
PULSe Select pulse source function

Query :FUNCTION[:SHAPE]? Query source function

Description This command is used to select the source function for the laser diode current source. The two functions are:

DC — With this source function, the source will output a DC level with the amplitude determined by the :SOUR1:CURR:AMPL command (see “Set amplitudes,” page 14-34).

PULSe — In this mode, the source will output a current pulse. The high and low amplitudes are set with the :SOUR1:CURR:AMPL and :SOUR1:CURR:LOW commands covered in “Set amplitudes,” page 14-47. The pulse width and delay are set with the :SOUR1:PULS:WIDT and :SOUR1:PULS:DEL commands (see “Set pulse times,” page 14-36).

Select source range

RANGe <n>

:SOURce[1]:CURRent:RANGe <n> Select range for laser diode current source

Parameters :<n> = 0 to 5.0 Specify source level (amps)
DEFault 500mA range
MINimum 500mA range
MAXimum 5A range
UP Select next higher range
DOWN Select next lower range

Query :RANGe? Query range for specified source
:RANGe? DEFault Query *RST default source range
:RANGe? MINimum Query lowest source range
:RANGe? MAXimum Query highest source range

Description This command is used to select the range for the laser diode current source. Range is selected by specifying the approximate current magnitude that you will be using. The instrument will then go to the lowest range that can accommodate that level.

For example, if you expect to source levels around 300mA, send the following command:

```
:SOURce1:CURRent:RANGe 0.3
```

The above command will select the 500mA range for the laser diode current source.

As listed in *Parameters*, you can also use the MINimum, MAXimum and DEFault parameters to manually select the source range. The UP parameter selects the next higher source range, while DOWN selects the next lower source range.

Set amplitudes

[:IMMEDIATE][:AMPLITUDE] <n>

:SOURce[1]:CURRent[:LEVel][:IMMEDIATE][:AMPLITUDE] <n> Set fixed current source amplitude

Parameters	<n> =	0 to 5.0	Set source amplitude (amps)
		DEFault	0A
		MINimum	0A
		MAXimum	5.0A

Query	:CURRent?	Query programmed source amplitude
	:CURRent? DEFault	Query *RST default amplitude
	:CURRent? MINimum	Query lowest allowable amplitude
	:CURRent? MAXimum	Query highest allowable amplitude

Description This command is used to immediately update the amplitude of a fixed source for both DC and pulse functions (with the pulse function, the amplitude is the high pulse level). This command is not valid if the list or sweep mode is selected.

NOTE The sourcing *:MODE* command is used to select a fixed source. See “*Select sourcing mode*,” page 14-32.

The specified amplitude cannot exceed the selected source range. For example, if the source is on the 500mA range, you will not be able to set the source amplitude to 1A.

NOTE For the DC function, the current cannot be set above 1A.

LOW <n>

:SOURce[1]:CURRent[:LEVel]:LOW <n> Set current pulse low amplitude

Parameters	<n> =	0 to 0.150	Set pulse low amplitude (amps)
		DEFault	0A
		MINimum	0A
		MAXimum	0.150A

Query	:LOW? :LOW? DEFault :LOW? MINimum :LOW? MAXimum	Query programmed low amplitude Query *RST default low amplitude Query lowest allowable low amplitude Query highest allowable low amplitude
Description	This command is used to set the pulse low amplitude level for all current source pulses. For the 500mA source range, the low value can be set from 0 to 0.015A. For the 5A source range, the low value can be set from 0 to 0.150A.	

NOTE This command sets the pulse low amplitude for the pulse source function in the list and sweep modes. See “[Select sourcing mode](#),” page 14-32, and “[Select source function](#),” page 14-33.

Set voltage limit

PROTection[:LEVel] <NRf>

:SOURce[1]:VOLTage:PROTection[:LEVel] <NRf> Set voltage compliance limit

Parameters <NRf> = 3 to 10.5 Set voltage compliance limit

Query :PROTection? Query programmed voltage limit

Description This command is used to set the voltage protection limit, which clamps the current source output voltage at the programmed limit. See [Section 5, “Current source operating boundaries,”](#) for more information.

Select source polarity

POLarity <name>

[:SOURce[1]]:CURRent:POLarity <name> Set laser diode current source polarity

Parameters <name> = POSitive Positive polarity
NEGative Negative polarity

Query :POLarity? Query measurement polarity

Description This command is used to select the polarity for the laser diode current source. POSitive selects normal polarity, while NEGative selects reversed polarity. See [Section 3, “Configuring measurements,”](#) for more information on polarity.

Set pulse times

DElAy <n>

	:SOURce[1]:PULSe:DElAy <n>		Set current source pulse delay
Parameters	<n> =	20e-6 to 0.5 MINimum MAXimum DEFault	Specify pulse delay in seconds 20e-6 seconds 0.5 seconds 10e-3 seconds
Query	:DElAy?		Query pulse delay
	:DElAy? DEFault		Query *RST default pulse delay
	:DElAy? MINimum		Query lowest allowable pulse delay
	:DElAy? MAXimum		Query highest allowable pulse delay
Description	This command is used to set the delay time between current pulses in the pulse function. It sets the pulse delay in the fixed and sweep modes, but it does not control pulse delays for the list mode, which are programmed separately (see “Configure list,” page 14-41).		

WIDTh <n>

	:SOURce[1]:PULSe:WIDTh <n>		Set current source pulse width
Parameters	<n> =	500e-9 to 5e-3 MINimum MAXimum DEFault	Specify pulse width in seconds 500e-9 seconds 5e-3 seconds 10e-6 seconds
Query	:WIDTh?		Query pulse width
	:WIDTh? DEFault		Query *RST default pulse width
	:WIDTh? MINimum		Query lowest allowable pulse width
	:WIDTh? MAXimum		Query highest allowable pulse width
Description	This command is used to set the current pulse width in the pulse function. It sets the pulse width in the fixed and sweep modes, but it does not control pulse widths for the list mode, which are programmed separately (see “Configure list,” page 14-41).		

TRANSition[:STATe]

	:SOURce[1]:PULSe:TRANSition:STATe 		Control pulse transition control state
Parameters	 =	0 or OFF 1 or ON	Disable transition control Enable transition control
Query	[:STATe]?		Query state of transition control
Description	This command enables or disables pulse transition (rise time) control. When off (0) the leading edge is as fast as the system hardware allows. When on (1), the turn on is intentionally slowed down to a fixed setting of 5e-6. (The output will not fully settle to its final value for 5μs.)		

Configure sweeps

There are two methods to configure the start and stop levels of a sweep. You can use either the :START and :STOP commands or you can use the :CENTER and :SPAN commands. See “Sweep and list program examples,” page 14-44.

NOTE In order to run a sweep, the source must be in the sweep sourcing mode.

Use the CURRENT:MODE command to select the SWEep sourcing mode. See “Select sourcing mode,” page 14-32.

SPACing <name>

:SOURce[1]:SWEep:SPACing <name> Select scale for current sweep

Parameters <name> = LINear Linear scale
LOGarithmic Logarithmic scale

Query :SPACing? Query scale for sweep

Description This command is used to select the scale for the sweep. With LINear selected, the source and measure points in the sweep will be performed on a linear scale. With LOGarithmic selected, the source and measure points will be performed on a logarithmic scale.

START <n>

STOP <n>

:SOURce[1]:CURRent:START <n> Specify start current level
:SOURce[1]:CURRent:STOP <n> Specify stop current level

Parameters <n> = 0 to 5.0 Set source level (amps)
DEFault 0A
MINimum 0A
MAXimum 5.0A

Query :START? Query start level for sweep
:START? DEFault Query *RST default level
:START? MINimum Query lowest allowable level
:START? MAXimum Query highest allowable level

:STOP? Query start level for sweep
:STOP? DEFault Query *RST default level
:STOP? MINimum Query lowest allowable level
:STOP? MAXimum Query highest allowable level

Description These commands are used to specify the start and stop levels for a sweep. When the sweep is started, the source will output the specified start level and measurements are performed.

The sweep continues until the source outputs the specified stop level. At this level, the instrument again performs another series of measurements and then stops the sweep.

The source and measure points in a sweep can be set by specifying a step size, or by specifying the number of source and measure points in the sweep. Refer to :STEP and :POINTs.

:START and :STOP are coupled to :CENTer and :SPAN. Thus, when start and stop values are changed, the values for center and span are affected as follows:

$$\text{Center} = (\text{Start} + \text{Stop}) / 2$$

$$\text{Span} = \text{Stop} - \text{Start}$$

CENTer <n>

SPAN <n>

:SOURce[1]:CURRent:CENTer <n>
 :SOURce[1]:CURRent:SPAN <n>

Specify center point of sweep
 Specify span of sweep

Parameters	<n> =	0 to 5.0	Set SPAN source level (amps)
		0 to 5.0	Set CENT source level (amps)
		DEFault	0A
		MINimum	0A (SPAN), 0A (CENT)
		MAXimum	5.0A (SPAN), 5.0A (CENT)

Query	:CENTer?	Query center point for sweep
	:CENTer? DEFault	Query *RST default level
	:CENTer? MINimum	Query lowest allowable level
	:CENTer? MAXimum	Query highest allowable level
	:SPAN?	Query span for sweep
	:SPAN? DEFault	Query *RST default level
	:SPAN? MINimum	Query lowest allowable level
	:SPAN? MAXimum	Query highest allowable level

Description A sweep can be configured by specifying center and span parameters. By specifying a center point, you can sweep through the operating point of a device. The span determines the sweep width with the operating point at the center of the sweep.

For example, assume you are testing a device that operates at 100mA, and you want to sweep from 80mA to 120mA. To do this, you would specify the center to be 100mA and the span to be 40mA (120 - 80).

Use the :STEP or :POINTs command to specify the number of source and measure points in the sweep.

:CENTer and :SPAN are coupled to START and :STOP. Thus, when center and span values are changed, the values for start and stop are affected as follows:

$$\text{Start} = \text{Center} - (\text{Span} / 2)$$

$$\text{Stop} = \text{Center} + (\text{Span} / 2)$$

STEP <n>

:SOURce[1]:CURRent:STEP <n> Specify step size for sweep

Parameters	<n> =	0 to 5.0	Set source level (amps)
		DEFault	0A
		MINimum	0A
		MAXimum	5.0A

Query	:STEP	Query step size for sweep
	:STEP? DEFault	Query *RST default level
	:STEP? MINimum	Query lowest allowable level
	:STEP? MAXimum	Query highest allowable level

Description This command is used to specify a step size for a linear sweep. When the sweep is started, the source level changes in equal steps from the start level to the stop level. A measurement is performed at each source step (including the start and stop levels).

NOTE This command cannot be used for a logarithmic sweep. Use the :POINTs command to set the source and measure points for a log sweep.

To avoid a setting conflicts error, make sure the step size is greater than the start value and less than the stop value.

The number of source and measure points in a linear sweep can be calculated as follows:

$$\text{Points} = [(\text{Stop} - \text{Start}) / \text{Step}] + 1$$

$$\text{Points} = (\text{Span} / \text{Step}) + 1$$

An alternate way to set the source and measure points in a linear sweep is to simply specify the number of source and measure points in the sweep using the :POINTs command.

Note that the :STEP and :POINTs commands are coupled. Changing the step size also changes the number of source and measure points. Conversely, changing the number of source and measure points changes the step size.

POINTs <n>

:SOURce[1]:SWEep:POINTs <n>

Set number of points for sweep

Parameters	<n> =	2 to 1000	Specify number of source-measure points
		MINimum	2
		MAXimum	1000
		DEFault	1000

Query	:POINTs?	Query number of sweep points
	:POINTs? DEFault	Query *RST default number of sweep points
	:POINTs? MINimum	Query lowest allowable number of sweep points
	:POINTs? MAXimum	Query highest allowable number of sweep points

Description The :POINTs command specifies the total number of source and measure points in a sweep. For a linear sweep, the source and measure points are equally spaced (stepped) between the start level and the stop level. For a log sweep, the source and measure points are equally spaced on a logarithmic scale. Note that the start and stop levels are source and measure points.

Step size for a linear sweep can be calculated as follows:

$$\text{Step Size} = (\text{Stop} - \text{Start}) / (\text{Points} - 1)$$

$$\text{Step Size} = \text{Span} / (\text{Points} - 1)$$

Step size for a logarithmic sweep can be calculated as follows:

$$\text{Log Step Size} = \frac{\log_{10}(\text{Stop}) - \log_{10}(\text{Start})}{\text{Points} - 1}$$

An alternate way to set the source and measure points in a sweep is to specify the step size using the :STEP command.

Note that the :POINTs and :STEP commands are coupled. Changing the number of source and measure points also changes the step size. Conversely, changing the step size changes the number of source and measure points.

DIRection <name>

:SOURce[1]:SWEep:DIRection <name>

Set direction of sweep

Parameters	<name> =	UP	Run sweep from start to stop
		DOWN	Run sweep from stop to start

Query	:DIRection?	Query direction of sweep
--------------	-------------	--------------------------

Description Normally, a sweep is run from the start level to the stop level. The :START and :STOP, or :CENTER and :SPAN commands are used to set these levels.

This command lets you change the execution direction of the sweep. With DOWN selected, the sweep will begin at the stop level and end at the start level. Selecting UP restores sweep operation to the normal start to stop direction.

Configure list

The list commands allow you to program a custom sweep of up to 100 points. Each point can be individually programmed for pulse amplitude, pulse width, and pulse delay.

CURRent <NRf list>

:SOURce[1]:LIST:CURRent <NRf list> Define current list

Parameters <NRf list> = NRf, NRf ... NRf
NRf = 0 to 5.0 Pulse high amplitude (amps)

Query :CURRent? Query current list

Description This command is used to define a list of current pulse values (up to 100) for the list sourcing mode of operation. When operation is started, the instrument will sequentially source each current pulse value in the list. A set of measurements are performed at each current pulse level. The pulse width and delay are set with the :WIDTh and :DELay commands (see below). The pulse low level is set with the :LOW command (see “Set amplitudes,” page 14-34).

The following command shows the proper format for defining a list using source values of 1A, 2A, and 5A:

```
:SOURce[1]:LIST:CURRent 1, 2, 5
```

In order to execute a source list, the selected source must be in the list sourcing mode. Use the :SOUR1:CURR:MODE command to select the LIST sourcing mode. See “Select sourcing mode,” page 14-32.

APPend <NRf list>

:SOURce[1]:LIST:CURRent:APPend <NRf list> Add value(s) to current list

Parameters <NRf list> = NRf, NRf ... NRf
NRf = 0 to 5.0 Source value (amps)

Description This command is used to add one or more values (up to 100) to a source list that already exists. The source values are appended to the end of the list. (By using multiple appended lists, up to 1000 points can be in a list.)

DElay <NRf list>

:SOURce[1]:LIST:DElay <NRf list> Define pulse delay list

Parameters <NRf list> = NRf, NRf ... NRf
 NRf = 20e-6 to 0.5 Pulse delay (seconds)

Query :DElay? Query pulse delay list

Description This command is used to define a list of pulse delays (up to 100) for the list sourcing mode of operation. When operation is started, the instrument will sequentially source each current pulse value in the list (see “CURRent <NRf list>,” page 14-41) with the programmed pulse width and delay. Each pulse delay point in the list corresponds to the equivalent point in the current and width lists.

The following command shows the proper format for defining a list using pulse delay values of 200µs, 400µs, and 500µs:

```
:SOURce[1]:LIST:DElay 200e-6, 400e-6, 500e-6
```

NOTE *If the pulse delay list is shorter than the current list, the last pulse delay value will be used for all subsequent current list points. If delay is not programmed, a default value of 1.5ms will be used, but the query will return 0.*

APPend <NRf list>

:SOURce[1]:LIST:DElay:APPend <NRf list> Add value(s) to pulse delay list

Parameters <NRf list> = NRf, NRf ... NRf
 NRf = 20e-6 to 0.5 Pulse delay (seconds)

Description This command is used to add one or more values (up to 100) to a pulse delay list that already exists. The pulse delay values are appended to the end of the list. (By using multiple appended lists, up to 1000 points can be in a list.)

POINts?

:SOURce[1]:LIST:DElay:POINts? Query length of pulse delay list

Description These commands are used to determine the length of the specified pulse delay list. The response message indicates the number of pulse delay values in the list.

Sweep and list program examples

Linear staircase sweep

Linear current sweep from 10mA to 100mA in 10mA increments:

```
*RST
SOUR1:SWE:SPAC LIN
SOUR1:CURR:STAR 10e-3
SOUR1:CURR:STOP 100e-3
SOUR1:CURR:STEP 10e-3
SOUR1:SWE:POIN? (returns 10)
SOUR1:CURR:MODE SWE
OUTP1 ON
INIT
```

List sweep

List sweep with 100mA, 200mA, 300mA, 400mA and 500mA current pulses; pulse widths of 10 μ s, 20 μ s, 40 μ s, 60 μ s, and 70 μ s; pulse delays of 100ms, 150ms, 200ms, 250ms, and 300ms:

```
*RST
SOUR1:LIST:CURR 100e-3, 200e-3, 300e-3, 400e-3, 500e-3
SOUR1:LIST:WIDT 10e-6, 20e-6, 40e-6, 60e-6, 70e-6
SOUR1:LIST:DEL 100e-3, 150e-3, 200e-3, 250e-3, 300e-3
SOUR1:LIST:CURR:POIN? (returns 5)
SOUR1:LIST:WIDT:POIN? (returns 5)
SOUR1:LIST:DEL:POIN? (returns 5)
SOUR1:CURR:MODE LIST
OUTP1 ON
INIT
```

Logarithmic staircase sweep

Logarithmic staircase sweep from 10mA to 100mA in 20 points:

```
*RST
SOUR1:SWE:SPAC LOG
SOUR1:CURRE:STAR 10e-3
SOUR1:CURRE:STOP 100e-3
SOUR1:SWE:POIN 20
SOUR1:CURRE:MODE SWE
OUTP1 ON
INIT
```

To determine the current source values that will be generated:

Start: 10 $\text{Log}_{10}(\text{Start}):$ 1

Stop: 100 $\text{Log}_{10}(\text{Stop}):$ 2

$$\begin{aligned}\text{LogStep} &= (\text{Log}_{10}(\text{Start}) - \text{Log}_{10}(\text{Stop})) / (\text{SWE:POIN} - 1) \\ &= (2-1) / (20 - 1) \\ &= 1/19 \\ &= 0.105263\end{aligned}$$

Now add the LogStep value to $\text{Log}_{10}(\text{Start})$ and to each subsequent result. This will create a list of Log_{10} Values. Next take the anti-log of each Log_{10} Value to get the actual sweep values:

Value#	Log_{10} Value	Sweep Value (mA)
1	1.0000000	10.000000
2	1.0526316	11.288379
3	1.1052632	12.742751
4	1.1578948	14.384501
5	1.2105263	16.237767
6	1.2631579	18.329807
7	1.3157895	20.691382
8	1.3684211	23.357217
9	1.4210527	26.366513
10	1.4736842	29.763514
11	1.5263158	33.598184
12	1.5789474	37.926905
13	1.6315790	42.813329
14	1.6842105	48.329299
15	1.7368421	54.555947
16	1.7894737	61.584823
17	1.8421053	69.519286
18	1.8947369	78.476007
19	1.9473684	88.586675
20	2.0000000	100.00000

SOURce2 and SOURce3

The SOURce2 and SOURce3 commands control the detector #1 and detector #2 voltage sources respectively.

Description This command is used to set the logic levels of the output lines of the Digital I/O port. When set high, the specified output line will be at approximately +5V. When set low, the output line will be at 0V.

Use the following table to determine the parameter value for the desired decimal digital output pattern:

OUT 4	OUT 3	OUT 2	OUT 1	Decimal value
L	L	L	L	0
L	L	L	H	1
L	L	H	L	2
L	L	H	H	3
L	H	L	L	4
L	H	L	H	5
L	H	H	L	6
L	H	H	H	7
H	L	L	L	8
H	L	L	H	9
H	L	H	L	10
H	L	H	H	11
H	H	L	L	12
H	H	L	H	13
H	H	H	L	14
H	H	H	H	15

L = Low (Gnd)
H = High (>+3V)

Setting bit size

BSIZe <n>

:SOURce4:BSIZe <NRf>

Set Digital I/O bit size

Parameters <NRf> = 4
16

Set 4-bit size
Set 16-bit size (2499-DIGIO option)

Query :BSIZe?

Query Digital I/O port bit size

Description This command sets the Digital I/O bit size to 4 or 16. The 16-bit size is available only with the 2499-DIGIO option connected to the Digital I/O port.

NOTE This command is not affected by *RST, :SYSTem:PRESet, or *RCL.

STATus subsystem

The STATus subsystem is used to control the status registers of the Model 2520. The commands in this subsystem are summarized in [Table 14-7](#).

NOTE These registers and the overall status structure are fully explained in [Section 11](#).

Read event registers

[:EVENT]?

:STATus:MEASurement[:EVENT]?	Read Measurement Event Register
:STATus:QUEStionable[:EVENT]?	Read Questionable Event Register
:STATus:OPERation[:EVENT]?	Read Operation Event Register

Description These query commands are used to read the contents of the status event registers. After sending one of these commands and addressing the Model 2520 to talk, a value is sent to the computer. This value indicates which bits in the appropriate register are set.

Program event enable registers

ENABle <NDN> or <NRf>

:STATus:MEASurement:ENABle <NDN> or <NRf>	Program Measurement Event Enable Register
:STATus:QUEStionable:ENABle <NDN> or <NRf>	Program Questionable Event Enable Register
:STATus:OPERation:ENABle <NDN> or <NRf>	Program Operation Event Enable Register

Parameters	<NDN> = #Bxx...x	Binary format (each x = 1 or 0)
	#Hx	Hexadecimal format (x = 0 to FFFF)
	#Qx	Octal format (x = 0 to 177777)
	<NRf> = 0 to 65535	Decimal format

Query :ENABle? Read an enable register

Description These commands are used to program the enable registers of the status structure. The binary equivalent of the parameter value that is sent determines which bits in the register gets set. See [Section 11](#) for details.

Read condition registers

CONDition?

:STATus:MEASurement:CONDition?
 :STATus:QUEStionable:CONDition?
 :STATus:OPERation:CONDition?

Read Measurement Condition
 Read Questionable Register
 Read Operation Condition

Description These query commands are used to read the contents of the condition registers.

Select default conditions

PRESet

:STATus:PRESet

Return registers to default conditions

Description When this command is sent, the following SCPI event registers are cleared to zero (0):

1. Operation Event Enable Register.
2. Event Enable Register.
3. Measurement Event Enable Register.

NOTE The Standard Event Register is not affected by this command.

Error queue

[:NEXT]?

:STATus:QUEue[:NEXT]?

Read Error Queue

Description As error and status messages occur, they are placed into the Error Queue. This query command is used to read those messages. See [Appendix B](#) for a list of messages.

NOTE The `:STATus:QUEue[:NEXT]?` query command performs the same function as the `:SYSTem:ERRor?` query command. See “*SYSTEM subsystem*,” page 14-51.

CLEar

:STATus:QUEue:CLEar

Clear Error Queue

Description This action command is used to clear the Error Queue of messages.

ENABLE <list>

:STATus:QUEue:ENABle <list> Enable messages for Error Queue

Parameters <list> = (numlist)
 where numlist is a specified list of messages that you wish to enable for the Error.

Query :ENABle? Query list of enabled messages

Description On power-up, all error messages are enabled and will go into the Error Queue as they occur. Status messages are not enabled and will not go into the queue. This command is used to specify which messages you want enabled. Messages not specified will be disabled and prevented from entering the queue.

DISable <list>

:STATus:QUEue:DISable <list> Disable messages for Error Queue

Parameters <list> = (numlist)
 where numlist is a specified list of messages that you wish to disable for the Error Queue.

Query :DISable? Query list of disabled messages

Description On power-up, all error messages are enabled and will go into the Error Queue as they occur. Status messages are not enabled and will not go into the queue. This command is used to specify which messages you want disabled. Disabled messages are prevented from going into the Error Queue.

SYSTEM subsystem

The SYSTEM subsystem contains miscellaneous commands that are summarized in [Table 14-8](#).

Default conditions

PRESet

:SYSTem:PRESet Return to :SYSTem:PRESet defaults

Description This command returns the instrument to states optimized for front panel operation. :SYSTem:PRESet defaults are listed in the SCPI tables ([Table 14-1](#) through [Table 14-10](#)).

POSetup

:SYSTEM:POSetup <name>

Program power-on defaults

Parameters	<name> =	RST	Power-up to *RST defaults
		PRESet	Power-up to :SYSTEM:PRESet defaults
		SAV0	Power-up to setup stored at memory location 0
		SAV1	Power-up to setup stored at memory location 1
		SAV2	Power-up to setup stored at memory location 2
		SAV3	Power-up to setup stored at memory location 3
		SAV4	Power-up to setup stored at memory location 4

Query :POSetup? Query power-on setup

Description This command is used to select the power-on defaults. With RST selected, the instrument powers up to the *RST default conditions. With PRES selected, the instrument powers up to the :SYSTEM:PRESet default conditions. Default conditions are listed in the SCPI tables (Table 14-1 through Table 14-10).

With the SAV0-4 parameters specified, the instrument powers-on to the setup that is saved in the specified location using the *SAV command.

Error queue

NOTE See Section 11 for details on the error queue.

[:NEXT]?

:SYSTEM:ERRor[:NEXT]?

Read oldest error (code and message)

Description As error and status messages occur, they are placed in the Error Queue. The Error Queue is a first-in, first-out (FIFO) register that can hold up to 10 messages. After sending this command and addressing the Model 2520 to talk, the oldest message is sent to the computer and is then removed from the queue.

NOTE The :STATus:Queue? command performs the same function as :SYSTEM:ERRor[:NEXT]?. See "STATus subsystem," page 14-49.

ALL?

:SYSTEM:ERRor:ALL?

Read all errors (codes and messages)

Description This query command is similar to the [:NEXT]? command except that all messages in the Error Queue are sent to the computer when the Model 2520 is addressed to talk. All messages are removed from the queue.

COUNT?

:SYSTem:ERRor:COUNT? Return the number of errors

Description After sending this command and addressing the Model 2520 to talk, a decimal number will be sent to the computer. That is the number of messages in the Error Queue.

CODE[:NEXT]?

:SYSTem:ERRor:CODE[:NEXT]? Read oldest error (code only)

Description This command is identical to the [:NEXT]? command, except only the code is returned. The message itself is not returned. The error is cleared from the queue.

CODE:ALL?

SYSTem:ERRor:CODE:ALL? Read all errors (codes only)

Description This query command is identical to the :ALL? command, except only the codes are returned. The actual messages are not returned. All errors are cleared from the queue.

CLear

:SYSTem:CLear Clear Error Queue

Description This action command is used to clear the Error Queue of messages.

Simulate key presses**KEY**

:SYSTem:KEY <NRf> Simulate key-press

Parameters	<NRf> =	1	RANGE ▲ key
		2	EDIT ▼ key
		3	EDIT ◀ key
		4	MENU key
		5	DETECTOR 1 I _{PD} key
		6	FILTER key
		7	DELAY key
		8	EDIT key
		9	COMPL key
		10	EDIT ▶ key
		11	EXIT key
		12	DETECTOR 2 V _B key
		13	DIG OUT key
		14	COMM key

15	LASER V_L key
16	MATH key
17	RANGE ▼ key
18	ENTER key
19	DETECTOR 2 I_{PD} key
20	TRIG key
21	SETUP key
22	LASER I_L key
23	LOCAL key
24	ON/OFF OUTPUT key
25	-----
26	EDIT ▲ key
27	SWEEP key
28	CONFIG key
29	DETECTOR 1 V_B key
30	RECALL key
31	PW key

Query	:KEY?	Query last “pressed” key.
Description	<p>This command is used to simulate front panel key presses. For example, to select the laser diode voltage measurement function (LASER V_L), you can send the following command to simulate pressing the LASER V_L key:</p> <pre>:syst:key 15</pre> <p>The parameter listing above provides the key-press code in numeric order.</p> <p>The queue for the :KEY? query command can only hold one key-press. When :KEY? is sent over the bus, and the Model 2520 is addressed to talk, the key-press code number for the last key pressed (either physically or with :KEY) is sent to the computer.</p> <p>The key-press code number for the last key pressed (either physically or with :KEY) is sent to the computer.</p>	

Read version of SCPI standard

VERsion?

:SYSTem:VERsion?

Read SCPI version

Description This query command is used to read the version of the SCPI standard being used by the Model 2520. Example code:

```
1996.0
```

The above response message indicates the version of the SCPI standard.

RS-232 interface

NOTE *The following commands are intended for use over the RS-232 interface, but they can also be used over the GPIB.*

LOCAL

:SYSTem:LOCAl

Take Model 2520 out of remote

Description

Normally, during RS-232 communications, front panel keys are operational. However, the user may wish to lock out front panel keys during RS-232 communications. See “[RWLock](#).”

This action command is used to remove the Model 2520 from the remote state and enables the operation of front panel keys in a manner similar to the GPIB GTL command.

REMOte

:SYSTem:REMOte

Place the Model 2520 in remote

Description

This action command is used to place the Model 2520 in the remote state in a manner similar to the GPIB REN command. In remote, the front panel keys will be locked out if local lockout is asserted. See “[RWLock](#).”

RWLock

:SYSTem:RWLock

Disable or enable front panel keys

Description

This command is used to enable local lockout in a manner similar to the GPIB LLO command (See [Section 10](#)). When enabled, the front panel keys except OUTPUT OFF are locked out (not operational) when the instrument is in remote. (See “[REMOte](#)”.) When disabled, the front panel LOCAL key is operational in remote.

Removing the instrument from remote (:SYST:LOCAl) restores front panel keys operation.

Reset timestamp

RESet

:SYSTem:TIME:RESet

Reset timestamp

Description

This action command is used to reset the absolute timestamp to 0 seconds. The timestamp also resets to 0 seconds every time the Model 2520 is turned on.

TRACe subsystem

The TRACe subsystem is mostly a diagnostic tool for debugging connections and setup. In normal operation, a 14-bit A/D converter in the Model 2520 samples at 10MHz rate, and then, an internal Digital Signal Processor (DSP) interprets the A/D samples over the pulse width in order to determine the pulse level value, or a DC average, which are then sent back to the user. Using the TRACe subsystem, it is possible to effectively bypass the DSP calculations and directly query single calibrated samples. This feature provides basic 14-bit 10MHz digital storage oscilloscope capabilities. You can reconstruct a pulse to determine pulse parameters such as settling times, overshoot, and undershoot.

NOTE *None of the TRACe features are available over front panel. TRAC:DATA? And TRAC:DATA:VAL? will return errors unless SOUR1:MODE is FIXed, TRIGGER:COUNT is 1, and a reading has been triggered.*

Read sample buffer

DATA?

:TRACe:DATA?

Read raw samples from buffer

Description This command returns the raw sample data taken during the latest triggered reading. The number of samples is specified by TRAC:DATA:POINts. The sample elements returned are specified by FORM:ELEM:TRAC (see “FORMat subsystem,” page 14-19).

VALue? [<NRf>]

:TRACe:DATA:VALue? [<NRf>]

Return specific sample

Description This command returns the specified sample after the start of the source current pulse. If no parameter is specified, it returns the sample that immediately followed the one returned for the previous TRAC:DATA:VAL? query. If no TRAC:DATA:VAL? query was sent after the last INIT command, it returns the first sample after start of pulse. The sample elements returned are specified by FORM:ELEM:TRAC (see “FORMat subsystem,” page 14-19).

Configure sample buffer

POINTS <n>

:TRACe:POINTs <n>

Specify number of samples

Parameters	<n> =	1 to 3000	Specify number of samples
		MINimum	1
		MAXimum	32000
		DEFault	100

Query	:POINTs?	Query number of samples
	:POINTs? MINimum	Query smallest allowable sample number
	:POINTs? MAXimum	Query largest allowable sample number
	:POINTs? DEFault	Query *RST default sample number

Description This command sets the number of samples to return for the TRAC:DATA? query. Every time the pulse width (SOUR:PULS:WIDTh) is changed, the TRAC:POINTs value defaults to either the (Pulse Width \times 10e6) in DC mode, or (Pulse Width \times 10e6 + 5) in pulse mode, or 3000, whichever is less. For example, if the pulse width is 10 μ s, the number of points will default to 100 in DC mode, or 105 in the pulse mode.

Trigger subsystem

The Trigger subsystem is made up of a series of commands and subsystems to configure the Trigger Model. These commands and subsystems are summarized in [Table 14-10](#).

NOTE See Section 8 for more details on triggering and the trigger model.

Initiate source/measure cycle

INITiate

:INITiate[:IMMediate]

Take Model 2520 out of idle state

Description This command is used to initiate source and measure operation by taking the Model 2520 out of idle. The :READ? and :MEASure? commands also perform an initiation.

Command processing will halt until the trigger model returns to the idle state, with the following exceptions:

- ABORt
- SDC
- DCL
- IFC
- SYSTem:PRESet, *RST, or *RCL
- *TRG or GET with TRIG:SOUR BUS

If any other command is sent after an INIT, only SDC, IFC, and DCL will work.

Abort source/measure cycle

ABORT Abort operation

Description When this action command is sent, the Model 2520 aborts operation and returns to the idle state.

A faster way to return to idle is to use the DCL or SDC command.

Program trigger model

COUNT <n>

:TRIGger[:SEquence[1]]:COUNT <n> Set trigger count

Parameters	<n> =	1 to 5000	Specify count
		DEFault	Sets count to 1
		MINimum	Sets count to 1
		MAXimum	5000
		INFinite	Run continuously

NOTE The product of the trigger count and the number of sweep points (SOUR1:SWE:POIN) cannot exceed 5000.

Query	:COUNT?	Queries programmed count
	:COUNT? DEFault	Queries *RST default count
	:COUNT? MINimum	Queries lowest allowable count
	:COUNT? MAXimum	Queries largest allowable count

Description This command is used to specify how many times the unit cycles through the trigger layer. For example, if the trigger count is set to 2, the unit will cycle through the trigger layer twice.

TRIGger:COUNT INFinite can be used for repetitive source waveforms or for long tests where only the last reading is important.

SOURce <name>

:TRIGger[:SEquence[1]]:SOURce <name> Specify trigger event control source

Parameters	<name> =	IMMEDIATE	Pass operation through immediately
		TLINK	Select Trigger Link trigger as event
		TIMER	Select timer as event
		MANual	Select manual event
		BUS	Select bus trigger as event
		NSTest	Select low SOT pulse as event
		PSTest	Select high SOT pulse as event
	BSTest	Select high or low SOT pulse as event	

Query	:SOURce?	Query programmed control source
Description	<p>This command is used to select the event control source. With IMMEDIATE selected, operation immediately continues.</p> <p>A specific event can be used to control operation. With TLINK selected, operation continues when a trigger pulse is received via the Trigger Link.</p> <p>With TIMER selected, the event occurs at the beginning of the timer interval, and every time it times out. For example, if the timer is programmed for a 30 second interval, the first pass through the control source occurs immediately. Subsequent trigger events will then occur every 30 seconds. The interval for the timer is set using the :TIMER command.</p> <p>With MANUAL selected, the event occurs when the TRIG key is pressed.</p> <p>With BUS selected, the event occurs when a GET or *TRG command is sent over the bus.</p> <p>With NSTest selected, the event occurs when the SOT (start-of-test) low pulse is received via the Digital I/O port SOT line.</p> <p>With PSTest selected, the event occurs when SOT (start-of-test) high pulse is received via the Digital I/O port SOT line.</p> <p>With BSTest selected, the event occurs when SOT (start-of-test) high or low pulse is received via the Digital I/O port SOT line.</p>	

TIMER <n>

	:TRIGger[:SEquence[1]][:LAYer[1]]:TIMER <n>	Set interval for trigger layer timer
Parameters	<n> =	0 to 99999.99 Specify timer interval in seconds
	DEFAULT	Sets timer to 0.1
	MINimum	Sets timer to 0
	MAXimum	Sets timer to

Query	:TIMER?	Queries programmed timer interval
	:TIMER? DEFAULT	Queries *RST default interval
	:TIMER? MINimum	Queries lowest allowable interval
	:TIMER? MAXimum	Queries largest allowable interval

Description	This command is used to set the interval for the timer. Note that the timer is in effect only if the timer is the selected control source.	
--------------------	--	--

ILINe <NRf>

:TRIGger[:SEQuence[1]][:TCONfigure]:ILINe <NRf> Select Trigger Link input line

Parameters	<NRf> =	1	Line #1
		2	Line #2
		3	Line #3
		4	Line #4
		5	Line #5
		6	Line #6

Query :ILINe? Query input trigger line

Description This command is used to select input lines for the Trigger Link. For normal operation, Trigger Link input and output (see “**OLINe <NRf>**”) should not share the same line.

OLINe <NRf>

:TRIGger[:SEQuence[1]][:TCONfigure]:OLINe <NRf> Select Trigger Link output line

Parameters	<NRf> =	1	Line #1
		2	Line #2
		3	Line #3
		4	Line #4
		5	Line #5
		6	Line #6

Query :OLINe? Query output trigger line

Description This command is used to select output lines for the Trigger Link. For normal operation, Trigger Link input and output (see “**ILINe <NRf>**”) should not share the same line.

OUTPut <name>

:TRIGger[:SEQuence[1]][:TCONfigure]:OUTPut <name> Enable/disable trigger output event

Parameters	<name > =	TRIGger	Trigger on exiting trigger layer
		NONE	Disable trigger layer output trigger

Query :OUTPut? Query output trigger event state

Description This command is used to specify whether or not trigger pulses occur on the specified output trigger line of the Trigger Link (:OLINe).
With TRIGger selected, an output trigger will occur when exiting the trigger layer. With NONE selected, the trigger layer output trigger is disabled.

A Specifications

2520 Pulsed Laser Diode Test System

LASER DIODE PULSE OR DC CURRENT SOURCE SPECIFICATIONS

SOURCE RANGE	DRIVE CURRENT				OFF CURRENT ⁴			
	PROGRAMMING RESOLUTION	APPROX. ELECTRICAL RESOLUTION	ACURACY ^{1,6} ± (% rdg. + mA) ^{2,3}	RMS NOISE (typical) (1kHz-20MHz)	RANGE	PROGRAMMING RESOLUTION	APPROX. ELECTRICAL RESOLUTION	ACURACY ¹ ± (% rdg. + mA)
0-500 mA	10 µA	8 µA	0.2 + 0.45	70 µA	0-15 mA	1 µA	7 nA typ.	0.2 + 0.45
0 – 1.0 A DC	100 µA	80 µA	0.2 + 4.5	800 µA	0-150 mA	10 µA	70 nA typ.	0.2 + 4.5
0 – 5.0 A Pulse								

TEMPERATURE COEFFICIENT (0°-18°C & 28°-50°C): ±(0.15 x accuracy specification)/°C.

PULSE ON TIME¹⁵: 500ns to 5ms, 100ns programming resolution.

PULSE OFF TIME¹⁹: 20µs to 500ms, 10µs programming resolution.

PULSE DUTY CYCLE^{19, 20, 21}: 0 to 99.6% for ≤ 1.0A; 0 to 4% for > 1.0A.

VOLTAGE COMPLIANCE: 3V to 10V, 10mV programming resolution⁵.

POLARITY: 1 quadrant source, polarity reversal available through internal relay inversion.

OUTPUT OFF: <200mΩ short across laser diode; measured at Remote Test Head connector.

SETTING AND RANGE	LOAD ⁷	PULSE MODE	PULSE OVERSHOOT	RISE/FALL TIME ^{6,8,9,10}	
				TYPICAL	MAX.
500mA	10Ω ¼ Watt	Fast	1.0%	55 ns	80 ns
500mA	10Ω ¼ Watt	Slow	0.1%	1 µs	1.3 µs
5.00A	1.5Ω 1 Watt	Fast	1.0%	100 ns	130 ns
5.00A	1.5Ω 1 Watt	Slow	0.1%	1 µs	1.3 µs

LASER DIODE VOLTAGE MEASURE SPECIFICATIONS

RANGE	MINIMUM RESOLUTION	ACURACY ± (% rdg. + volts) ^{1,12}	RMS NOISE (typical) ¹³
5.00 V	0.33 mV	0.3% + 6.5 mV	60 µV
10.00 V	0.66 mV	0.3% + 8 mV	120 µV

TEMPERATURE COEFFICIENT (0°-18°C & 28°-50°C): ±(0.15 x accuracy specification)/°C.

MAX. LEAD RESOLUTION: 100Ω for rated accuracy.

INPUT IMPEDANCE: 2MΩ differential, 1MΩ from each input to common. Input bias current ±7.5µA max.

PHOTODIODE VOLTAGE BIAS SOURCE SPECIFICATIONS (each channel)

RANGE: 0 to ±20VDC.

PROGRAMMING RESOLUTION: 10mV.

ACCURACY: ±(1% + 50mV).

CURRENT: 160mA max. with V-Bias shorted to I-Measure.

RMS NOISE (1kHz to 5MHz): 1mV typical.

PHOTODIODE CURRENT MEASURE SPECIFICATIONS (each channel)

RANGE	MINIMUM RESOLUTION ⁴	DC INPUT IMPEDANCE	ACURACY ± (% rdg. + current) ^{1,2}	RMS NOISE (typical) ³
10.00 mA	0.7 µA	< 10 Ω	0.3% + 20 µA	90 nA
20.00 mA	1.4 µA	< 6 Ω	0.3% + 65 µA	180 nA
50.00 mA	3.4 µA	< 3 Ω	0.3% + 90 µA	420 nA
100.00 mA	6.8 µA	< 2.5 Ω	0.3% + 175 µA	840 nA

TEMPERATURE COEFFICIENT (0°-18°C & 28°-50°C): ±(0.15 x accuracy specification)/°C.

INPUT PROTECTION: The input is protected against shorting to the associated channel's internal bias supply. The input is protected for shorts to external supplies up to 20V for up to 1 second with no damage, although calibration may be affected.

SYSTEM SPEEDS

Reading Rates (ms)^{15,16}

Number of Source Points ¹⁷	To Memory	To GPIB
1	5.3	6.8
10 ^[18]	9.5	18
100 ^[18]	48	120
1000 ^[18]	431	1170

GENERAL SPECIFICATIONS

DC FLOATING VOLTAGE: User may float common ground up to ±10VDC from chassis ground.

COMMON MODE ISOLATION: >10⁹Ω.

OVERRANGE: 105% of range on all measurements and voltage compliance.

SOURCE OUTPUT MODES:

- Fixed DC Level
- Fixed Pulse Level
- DC Sweep (linear, log and list)
- Pulse Sweep (linear, log and list)
- Continuous Pulse (continuous – low jitter)

PROGRAMMABILITY: -IEEE-488 (SCPI-1995.0), RS-232, 5 user-definable power-up states plus factory default and *RST.

DIGITAL INTERFACE:

Safety Interlock: External mechanical contact connector and removable key switch.

Aux. Supply: +5V @ 300mA supply.

Digital I/O: 2 trigger input, 4 TTL/Relay Drive outputs (33V @ 500mA max., diode clamped).

Tlink: 6 programmable trigger input/outputs.

Pulse Trigger Out BNC: +5V, 50Ω output impedance, output trigger corresponding to current source pulse; pulse to trigger delay <100ns. See Figure 3.

MAINS INPUT: 100V to 240V rms, 50-60Hz, 140VA.

WARRANTY: 1 year.

EMC: Conforms to European Union Directive 89/336/EEC (EN61326-1).

SAFETY: Conforms to European Union Directive 73/23/EEC (EN61010-1) CAT 1.

VIBRATION: MIL-PRF-28800F Class 3, Random.

WARM-UP: 1 hour to rated accuracy.

DIMENSIONS, WEIGHT:

Main Chassis, bench configuration (with handle & feet): 105mm high × 238mm wide × 416mm deep (4 1/8 in. × 9 3/8 in. × 16 3/8 in.), 2.67kg (5.90 lbs).

Remote Test Head: 95mm high × 178mm deep (with interlock key installed) × 216mm wide (3 1/2 in. × 7 in. × 8 1/2 in.), 1.23kg (2.70 lbs).

ENVIRONMENT:

Operating: 0°-50°C, 70% R.H. up to 35°C. Derate 3% R.H./°C, 35°-50°C.

Storage: -25° to 65°C.

2520 Pulsed Laser Diode Test System

Notes

- ¹ 1 year, 23°C ±5°C.
- ² If $\sqrt{\text{Duty Cycle}} \cdot I$ exceeds 0.2, accuracy specifications must be derated with an additional error term as follows:
 500mA Range: $\pm 0.1\% \text{ rdg.} \cdot \sqrt{D} \cdot I$
 5A Range: $\pm 0.3\% \text{ rdg.} \cdot \sqrt{D} \cdot I$
 where: I = current setting
 D = duty cycle

This derating must also be applied for a period equal to the time that $\sqrt{D} \cdot I$ was ≥ 0.2 .

- ³ Not including overshoot and setting time.
- ⁴ Pulse mode only.
- ⁵ Output: 500mA DC on 500mA range and 1A DC on 5A range.
- ⁶ Refer to 2520 Service Manual for test setup of current accuracy.
- ⁷ Figures 1 and 2 are typical pulse outputs into resistive loads.
- ⁸ Typical
- ⁹ Per ANSI/IEEE Std 181-1977.
- ¹⁰ Per ANSI/IEEE Std 181-1977 10% to 90%.
- ¹¹ DC accuracy $\pm 700\text{mV}$ @ output terminal. 0.2Ω typical output impedance.
- ¹² At DC, $10\mu\text{s}$ measurement pulse width, Filter off.
- ¹³ Standard deviation of 10,000 readings with $10\mu\text{s}$ pulse width, filter off, with I source set to 0 amps DC.
- ¹⁴ The A/D converter has 14 bit resolution. The useful resolution is improved by reading averaging. The useful resolution is:

$$\text{Useful Resolution} = \frac{\text{Range}}{2^{14}} \cdot \frac{1}{\sqrt{\frac{\text{Pulse Width (ns)} - 400\text{ns}}{100\text{ns}} \cdot \text{Averaging Filter Setting}}}$$

- ¹⁵ Excluding total programmed (Pulse ON time + Pulse OFF time).
- ¹⁶ Front panel off, calc off, filter off, duty cycle < 10%, binary communications.
- ¹⁷ Returning 1 voltage and 2 current measurements for each source point.
- ¹⁸ Sweep mode.
- ¹⁹ Valid for both continuous pulse and sweep modes.
- ²⁰ Shown is the Power Distribution % based on current settings.
- ²¹ Timing Cycle ($t^{\text{pw}} / (\text{pw} + \text{pd})$): 4% max.

Specifications are subject to change without notice.

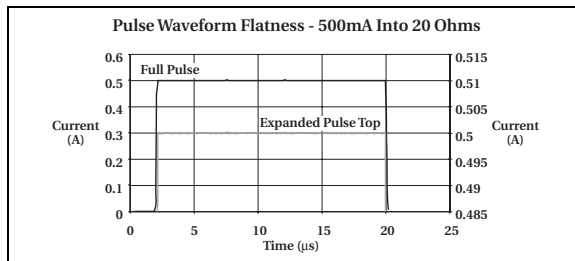

Figure 1

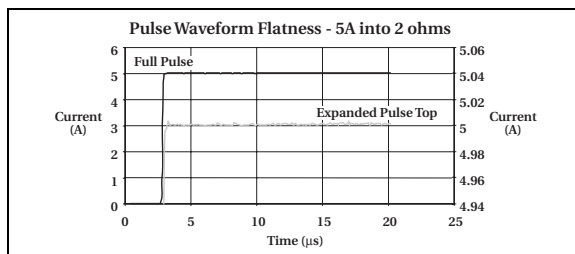

Figure 2

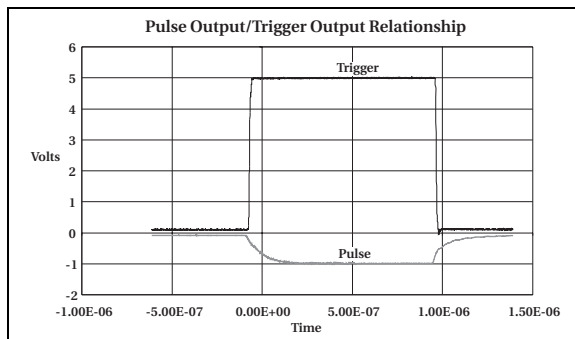

Figure 3

Accuracy calculations

The following information discusses how to calculate accuracy for both measurement and source functions.

Measurement accuracy

Measurement accuracy is calculated as follows:

$$\text{Accuracy} = \pm(\% \text{ of reading} + \text{offset})$$

As an example of how to calculate the actual reading limits, assume that you are measuring 5V on the 10V laser diode measurement range. You can compute the reading limit range from one-year measurement specifications as follows:

$$\begin{aligned} \text{Accuracy} &= \pm(\% \text{ of reading} + \text{offset}) \\ &= \pm[(0.3\% \times 5\text{V}) + 8\text{mV}] \\ &= \pm(15\text{mV} + 8\text{mV}) \\ &= \pm 23\text{mV} \end{aligned}$$

Thus, the actual reading range is 5V \pm 23mV or from 4.977V to 5.023V.

Source accuracy

Source accuracy is calculated similarly, except that source specifications are used to calculate source accuracy as follows:

$$\text{Accuracy} = \pm(\% \text{ of setting} + \text{offset})$$

As an example of how to calculate the actual source output limits, assume that you are sourcing 100mA DC on the 500mA range. You can compute the output limits from laser diode current source one-year accuracy specifications as follows:

$$\begin{aligned} \text{Accuracy} &= \pm(0.2\% \text{ of setting} + 0.45\text{mA offset}) \\ &= \pm[(0.2\% \times 100\text{mA}) + 0.45\text{mA}] \\ &= \pm(0.2\text{mA} + 0.45\text{mA}) \\ &= \pm 0.65\text{mA} \end{aligned}$$

In this case, the actual current source output range is 100mA \pm 0.65mA or from 99.35mA to 100.65mA.

B

Status and Error Messages

Introduction

This Appendix contains a summary of status and error messages, which status register bits are set when messages occur, and methods to avoid or eliminate most common SCPI errors.

Status and error messages

Table B-1 summarizes status and error messages, which are stored in the Error Queue. Each message is preceded by a code number. Negative (-) numbers are used for SCPI-defined messages, and positive (+) numbers are used for Keithley-defined messages. Note that error and status conditions will also set specific bits in various status registers, as summarized in Table B-1.

Section 11 has detailed information on registers and queues. Briefly, you can use the following queries to obtain error and status information:

- `:SYST:ERR?` — reads Error Queue.
- `*ESR?` — reads Standard Event Status Register.
- `:STAT:OPER?` — reads Operation Event Register.
- `:STAT:MEAS?` — reads Measurement Event Register.
- `:STAT:QUES?` — reads Questionable Event Register.

NOTE *SCPI-confirmed messages are described in volume 2: Command Reference of the Standard Commands for Programmable Instruments. Refer to the `:SYSTem:ERRor?` command.*

Table B-1
Status and error messages

Number	Error message	Event ¹	Status register ²	Bit
-440	Query UNTERMINATED after indefinite response	EE	Standard Event	2
-430	Query DEADLOCKED	EE	Standard Event	2
-420	Query UNTERMINATED	EE	Standard Event	2
-410	Query INTERRUPTED	EE	Standard Event	2
-363	Input buffer overrun	EE	Standard Event	3
-362	Framing error in program message	EE	Standard Event	3
-361	Parity error in program message	EE	Standard Event	3
-360	Communications error	EE	Standard Event	3
-350	Queue overflow	SYS	Standard Event	3
-330	Self-test failed	EE	Standard Event	3
-314	Save/recall memory lost	EE	Standard Event	3
-315	Configuration memory lost	EE	Standard Event	3
-285	Program syntax error	EE	Standard Event	4
-284	Program currently running	EE	Standard Event	4
-282	Illegal program name	EE	Standard Event	4
-281	Cannot create program	EE	Standard Event	4
-260	Expression error	EE	Standard Event	4
-241	Hardware missing	EE	Standard Event	4
-230	Data corrupt or stale	EE	Standard Event	4
-225	Out of memory	EE	Standard Event	4
-224	Illegal parameter value	EE	Standard Event	4
-223	Too much data	EE	Standard Event	4
-222	Parameter data out of range	EE	Standard Event	4
-221	Settings conflict	EE	Standard Event	4
-220	Parameter error	EE	Standard Event	4
-215	Arm deadlock	EE	Standard Event	4
-214	Trigger deadlock	EE	Standard Event	4
-213	Init ignored	EE	Standard Event	4
-212	Arm ignored	EE	Standard Event	4
-211	Trigger ignored	EE	Standard Event	4
-210	Trigger error	EE	Standard Event	4
-202	Settings lost due to rtl	EE	Standard Event	4
-201	Invalid while in local	EE	Standard Event	4
-200	Execution error	EE	Standard Event	4

Table B-1 (continued)
Status and error messages

Number	Error message	Event ¹	Status register ²	Bit
-178	Expression data not allowed	EE	Standard Event	5
-171	Invalid expression	EE	Standard Event	5
-170	Expression error	EE	Standard Event	5
-168	Block data not allowed	EE	Standard Event	5
-161	Invalid block data	EE	Standard Event	5
-160	Block data error	EE	Standard Event	5
-158	String data not allowed	EE	Standard Event	5
-154	String too long	EE	Standard Event	5
-151	Invalid string data	EE	Standard Event	5
-150	String data error	EE	Standard Event	5
-148	Character data not allowed	EE	Standard Event	5
-144	Character data too long	EE	Standard Event	5
-141	Invalid character data	EE	Standard Event	5
-140	Character data error	EE	Standard Event	5
-128	Numeric data not allowed	EE	Standard Event	5
-124	Too many digits	EE	Standard Event	5
-123	Exponent too large	EE	Standard Event	5
-121	Invalid character in number	EE	Standard Event	5
-120	Numeric data error	EE	Standard Event	5
-114	Header suffix out of range	EE	Standard Event	5
-113	Undefined header	EE	Standard Event	5
-112	Program mnemonic too long	EE	Standard Event	5
-111	Header separator error	EE	Standard Event	5
-110	Command header error	EE	Standard Event	5
-109	Missing parameter	EE	Standard Event	5
-108	Parameter not allowed	EE	Standard Event	5
-105	GET not allowed	EE	Standard Event	5
-104	Data type error	EE	Standard Event	5
-103	Invalid separator	EE	Standard Event	5
-102	Syntax error	EE	Standard Event	5
-101	Invalid character	EE	Standard Event	5
-100	Command error	EE	Standard Event	5
+000	No error	SE		

Table B-1 (continued)
Status and error messages

Number	Error message	Event ¹	Status register ²	Bit
	Measurement events:			
+101	Hardware interlock asserted	SE	Measurement Event	1
+102	Laser diode measurement overflow	SE	Measurement Event	2
+103	Detector 1 measurement overflow	SE	Measurement Event	3
+104	Detector 2 measurement overflow	SE	Measurement Event	4
+106	Reading available	SE	Measurement Event	6
+107	Sweep aborted	SE	Measurement Event	7
+108	Sweep done	SE	Measurement Event	8
+114	Current source in compliance	SE	Measurement Event	14
	Standard events:			
+200	Operation complete	SE	Standard Event	0
	Operation events:			
+300	Device calibrating	SE	Operation Event	0
+305	Waiting in trigger layer	SE	Operation Event	5
+310	Entering idle layer	SE	Operation Event	10
	Questionable events:			
+408	Questionable Calibration	SE	Questionable Event	8
+414	Command Warning	SE	Questionable Event	14
	Calibration errors:			
+500	Date of calibration not set	EE	Standard Event	3
+501	Next date of calibration not set	EE	Standard Event	3
+502	Calibration data invalid	EE	Standard Event	3
+503	DAC calibration overflow	EE	Standard Event	3
+504	DAC calibration underflow	EE	Standard Event	3
+505	Source offset data invalid	EE	Standard Event	3
+506	Source gain data invalid	EE	Standard Event	3
+507	Measurement offset data invalid	EE	Standard Event	3
+508	Measurement gain data invalid	EE	Standard Event	3
+509	Not permitted with cal locked	EE	Standard Event	3
+510	Not permitted with cal unlocked	EE	Standard Event	3

Table B-1 (continued)
Status and error messages

Number	Error message	Event ¹	Status register ²	Bit
	Lost data errors:			
+601	Reading buffer data lost	EE	Standard Event	3
+602	GPIB address lost	EE	Standard Event	3
+603	Power-on state lost	EE	Standard Event	3
+604	Calibration data lost	EE	Standard Event	3
+605	Calibration dates lost	EE	Standard Event	3
+606	GPIB communication language lost	EE	Standard Event	3
	Communication errors:			
+700	Invalid system communication	EE	Standard Event	3
+701	ASCII only with RS-232	EE	Standard Event	3
+702	DSP communication timeout	EE	Standard Event	3
	Additional command execution errors:			4
+802	OUTPUT blocked by interlock	EE	Standard Event	4
+803	Not permitted with OUTPUT off	EE	Standard Event	
+810	OUTPUT blocked by over temp	EE	Standard Event	4
+830	Invalid with INF TRIG:COUNT	EE	Standard Event	4
+900	Internal System Error	EE	Standard Event	3

- EE = Error Event
SE = Status Event
SYS = System Error Event
- Use following queries to read status registers:
Standard Event: *ESR?
Operation Event: STAT:OPER?
Measurement Event: STAT:MEAS?
Questionable Event: STAT:QUES?

Eliminating common SCPI errors

There are three SCPI errors that occur more often than any others:

- -113, "Undefined header"
- -410, "Query INTERRUPTED"
- -420, "Query UNTERMINATED"

The following paragraphs discuss the most common causes for these errors and methods for avoiding them.

-113, "Undefined header"

This error indicates that the command you sent to the instrument did not contain a recognizable command name. The most likely causes for this error are:

- Missing space between the command and its parameter. There must be one or more spaces (blanks) between the command and its parameter. For example:

:SENS2:CURR:RANG10e-3 Incorrect (no space between command and parameter)

:SENS2:CURR:RANG 10e-3 Correct

- Improper short or long form. Check the command list in [Section 14](#) for the correct command name.
- Blanks (spaces) within the command name. For example:

:SYST :ERR? Incorrect (space between :SYST and :ERR?)

:SYST:ERR? Correct

-410, "Query INTERRUPTED"

This error occurs when you have sent a valid query to the instrument, and then send it another command or query, or a Group Execute Trigger (GET) before it has had a chance to send the entire response message (including the line-feed/EOI terminator). The most likely causes are:

- Sending a query to the instrument and then sending another command or query before reading the response to the first query. For example, the following sequence of commands will cause an error -410:

```
:SYST:ERR?
```

```
*OPC?
```

This sequence generates an error because you must read the response to :SYST:ERR? before sending the *OPC? query.

- Incorrectly configured IEEE-488 driver. The driver must be configured so that when talking on the bus it sends line-feed with EOI as the terminator, and when listening on the bus it expects line-feed with EOI as the terminator. See the reference manual for your particular IEEE-488 interface.

-420, "Query UNTERMINATED"

This error occurs when you address the instrument to talk, and there is no response message to send. The most likely causes are:

- Not sending a query. You must send a valid query to the instrument before addressing it to talk.
- Sending an invalid query. If you have sent a query and still get this error, make sure that the instrument is processing the query without error. For example, sending an ill-formed query that generates an error -113, "Undefined header" and then addressing the instrument to talk will generate an error -420, "Query UNTERMINATED" as well.
- Valid query following an invalid command. This situation can occur when you send multiple commands or queries (program message units) within one command string (program message). When the Model 2520 detects an error in a program message unit, it discards all further program message units until the end of the string; for example:

```
:SENS1:DATE?; :SOUR1:CURR?
```

In the above program message, the program message unit :SENS1:DATE? will generate error -113, "Undefined header", and the Model 2520 will discard the second program message unit :SOUR1:CURR? even though it is a valid query.

C Data Flow

Introduction

Data flow for remote operation is summarized by the block diagram shown in Figure C-1. Refer to this block diagram for the following discussion.

Figure C-1
Data flow block diagram

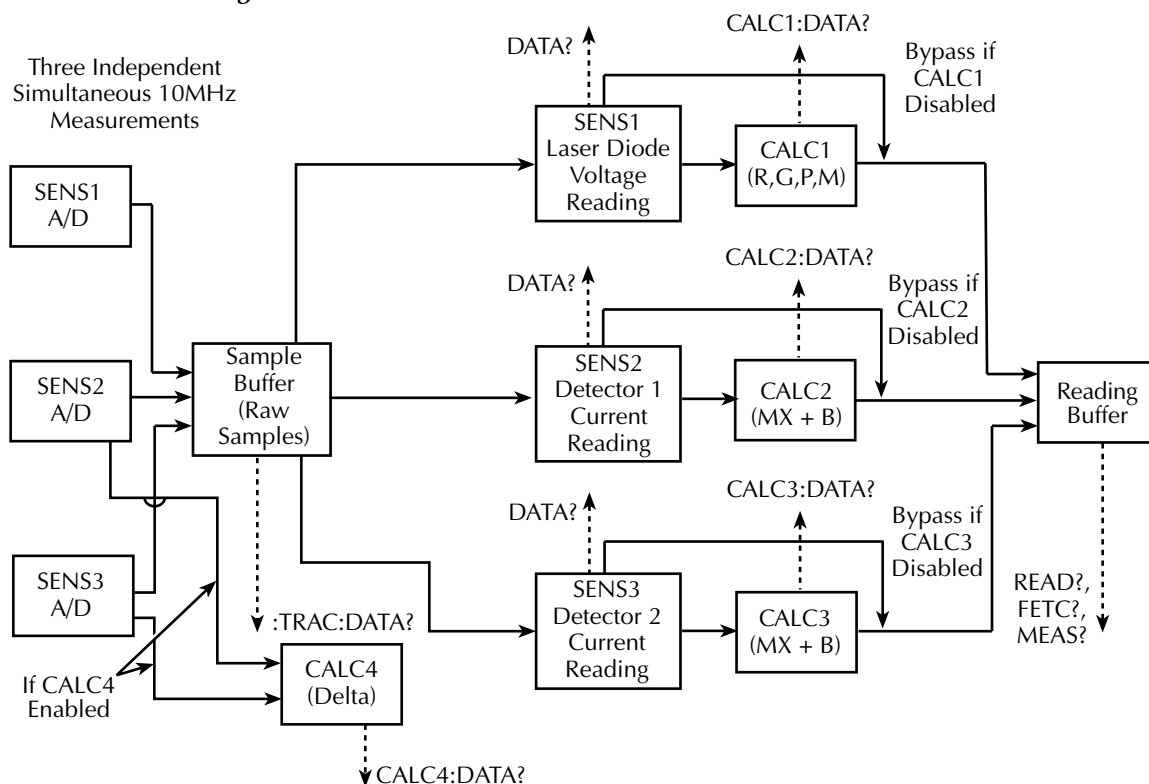

Buffers

There are two types of buffers used in the Model 2520:

- Sample buffer: stores individual raw samples from the three 14-bit, 10MHz A/D converters (one each for SENS1, SENS2, and SENS3). These raw samples are processed by the DSP section to form processed readings and can be directly accessed with the :TRACe commands (see below).
- Reading buffer: stores processed readings from the DSP. For the fixed mode of operation, the number of readings is equal to the trigger count. For sweep or list mode operation, the reading buffer stores all sweep data with the number of readings determined both by sweep parameters and the trigger count. The FETCh?, READ?, and MEASure? queries access data from the reading buffer (see below).

SENS1, SENS2, and SENS3

The SENS1 block represents the basic laser diode voltage readings. The SENS2 and SENS3 blocks represent the basic measured current readings for photodiode detector #1 and photodiode detector #2 respectively. If the filter is enabled, the readings will be filtered. The SENS blocks also measure time for the timestamp. Readings can be taken directly from one of the SENS blocks with one of the DATA? queries when the unit is in idle.

INIT

When the INITiate command is sent, the programmed number of source and measure operations are performed, and the respective data is temporarily stored in a reading buffer. For example, if 20 source and measure operations were performed, then 20 sets of data will be stored in the reading buffer. Data from this buffer is then routed to other enabled data flow blocks.

NOTE If the Model 2520 is in the fixed mode, it will process one set of readings per trigger. If the unit is in the sweep mode, it will process one sweep per trigger. The number of readings per sweep depends on programmed sweep parameters.

The data that is output by the read commands (FETCh? and READ?) depend on which data elements are selected. With all elements selected, available data includes both voltage and current measurements, source values, as well as the timestamp and status information. See [Section 14, :FORMat:ELEMents](#), “[SCPI Command Reference](#)” for details.

After all source and measure operations are completed, the Model 2520 returns to the idle state. The data stored in the reading buffer will remain there until data from another source-measure cycle overwrites the buffer. Data in the reading buffer is lost if the Model 2520 goes to the local state (REM annunciator off).

NOTE With no data in the reading buffer, sending the FETCh? and CALCulateX:DATA? commands to read data will display the message “Data corrupt or stale.”

FETCh?

This command is used to read processed data from the reading buffer. If, for example, there are 20 data sets stored in the reading buffer (in the sweep mode), then all 20 data sets will be sent to the computer when FETCh? is executed. Note that FETCh? does not affect processed data in the reading buffer. Thus, subsequent executions of FETCh? acquire the same data.

READ? and MEASure?

The READ? and MEASure? commands perform an INITiate and then a FETCh?. The INITiate command triggers a new source and measure cycle which puts new data in the reading buffer after processing by the DSP. FETCh? reads that new processed data. See [Section 13](#) for more information on READ? and MEASure?.

CALCulate1:DATA?, CALCulate2:DATA?, CALCulate3:DATA?

If CALCulate1, CALCulate2, or CALCulate3 is enabled, SENS1, SENS2, or SENS3 data is fed to the CALC1 (laser diode), CALC2 (detector #1), or CALC2 (detector #2) block where the results for the selected math function are calculated. The CALC1:DATA?, CALC2:DATA?, or CALC3:DATA? command will read the results of the math function.

CALCulate4:DATA?

If CALC4 is enabled, the DSP subtracts individual A/D detector #2 readings from A/D detector #1 readings, and then determines the pulse value or DC average over the pulse width from this new set of delta values.

TRACe:DATA? and TRACe:DATA:VALue?

All normal readings returned by FETCh?, READ?, MEASure?, and CALCulateX:DATA? are derived from samples acquired by a 14-bit A/D converter that samples at 10MHz rate. An internal DSP section interprets the A/D samples over the pulse width in order to determine the pulse level value, or a DC average, which is stored in the reading buffer and then sent back to the computer when requested by these commands.

With the TRACe subsystem you can bypass DSP calculations and directly query individual raw samples, allowing you to reconstruct a pulse to determine pulse parameters such as settling times, overshoot, and undershoot. These samples can be requested by the TRACe:DATA? query, which acquires all raw samples, and the :TRACe:DATA:VALue? query, which requests specific samples.

See [Section 14](#), “TRACe subsystem,” for details.

D

IEEE-488 Bus Overview

Introduction

Basically, the IEEE-488 bus is a communication system between two or more electronic devices. A device can be either an instrument or a computer. When a computer is used on the bus, it serves to supervise the communication exchange between all the devices and is known as the controller. Supervision by the controller consists of determining which device will talk and which device will listen. As a talker, a device will output information and as a listener, a device will receive information. To simplify the task of keeping track of the devices, a unique address number is assigned to each one.

On the bus, only one device can talk at a time and is addressed to talk by the controller. The device that is talking is known as the active talker. The devices that need to listen to the talker are addressed to listen by the controller. Each listener is then referred to as an active listener. Devices that do not need to listen are instructed to unlisten. The reason for the unlisten instruction is to optimize the speed of bus information transfer since the task of listening takes up bus time.

Through the use of control lines, a handshake sequence takes place in the transfer process of information from a talker to a listener. This handshake sequence helps ensure the credibility of the information transfer. The basic handshake sequence between an active controller (talker) and a listener is as follows:

1. The listener indicates that it is ready to listen.
2. The talker places the byte of data on the bus and indicates that the data is available to the listener.
3. The listener, aware that the data is available, accepts the data and then indicates that the data has been accepted.
4. The talker, aware that the data has been accepted, stops sending data and indicates that data is not being sent.
5. The listener, aware that there is no data on the bus, indicates that it is ready for the next byte of data.

Bus description

The IEEE-488 bus, which is also frequently referred to as the GPIB (General Purpose Interface Bus), was designed as a parallel transfer medium to optimize data transfer without using an excessive number of bus lines. In keeping with this goal, the bus has only eight data lines that are used for both data and with most commands. Five bus management lines and three handshake lines round out the complement of bus signal lines.

A typical set up for controlled operation is shown in [Figure D-1](#). Generally, a system will contain one controller and a number of other instruments to which the commands are given. Device operation is categorized into three operators: controller, talker, and listener. The controller does what its name implies; it controls the instruments on the bus. The

talker sends data while a listener receives data. Depending on the type of instrument, any particular device can be a talker only, a listener only, or both a talker and listener.

There are two categories of controllers: system controller and basic controller. Both are able to control other instruments, but only the system controller has the absolute authority in the system. In a system with more than one controller, only one controller may be active at any given time. Certain protocol is used to pass control from one controller to another.

The IEEE-488 bus is limited to 15 devices, including the controller. Thus, any number of talkers and listeners up to that limit may be present on the bus at one time. Although several devices may be commanded to listen simultaneously, the bus can have only one active talker, or communications would be scrambled.

A device is placed in the talk or listen state by sending an appropriate talk or listen command. These talk and listen commands are derived from an instrument's primary address. The primary address may have any value between 0 and 30, and is generally set by rear panel DIP switches or programmed from the front panel of the instrument. The actual listen address value sent out over the bus is obtained by ORing the primary address with #H20. For example, if the primary address is decimal 26 (#H1A), the actual listen address is #H3A (#H3A = #H1A + #H20). In a similar manner, the talk address is obtained by ORing the primary address with #H40. With the present example, the talk address derived from a primary address of 26 decimal would be #H5A (#H5A = #H1A + #H40).

The IEEE-488 standards also include another addressing mode called secondary addressing. Secondary addresses lie in the range of #H60-#H7F. Note, however, that many devices, including the Model 2520, do not use secondary addressing.

Once a device is addressed to talk or listen, the appropriate bus transactions take place. For example: if the instrument is addressed to talk, it places its data string on the bus one byte at a time. The controller reads the information and the appropriate software can be used to direct the information to the desired location.

Figure D-1
IEEE-488 bus configuration

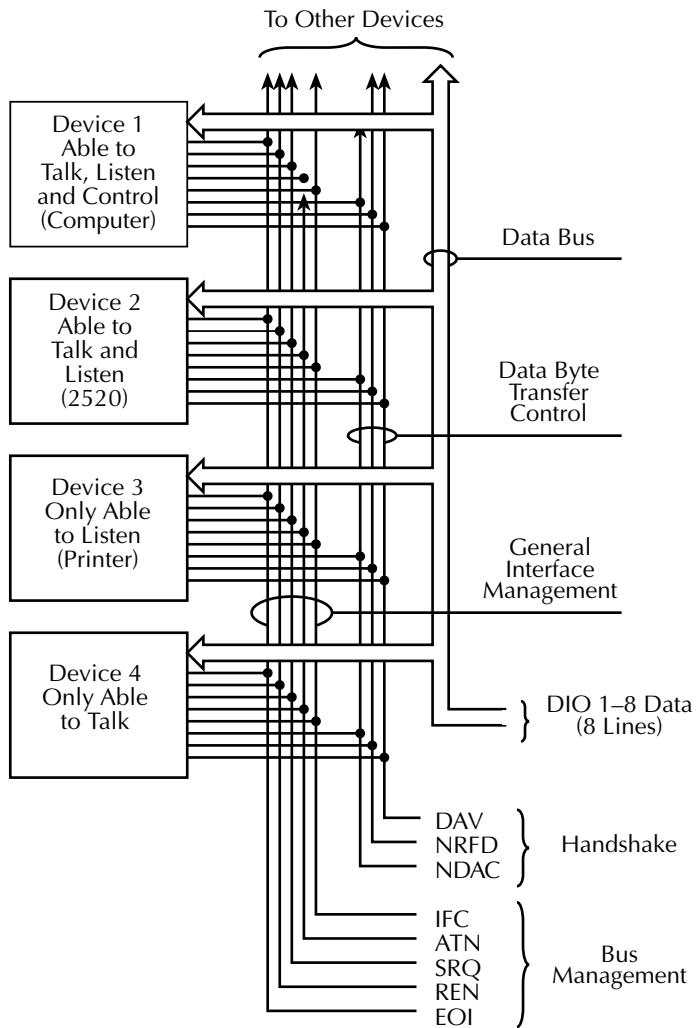

Bus lines

The signal lines on the IEEE-488 bus are grouped into three different categories: data lines, management lines, and handshake lines. The data lines handle bus data and commands, while the management and handshake lines ensure that proper data transfer and operation takes place. Each bus line is active low, with approximately zero volts representing a logic 1 (true). The following paragraphs describe the operation of these lines.

Data lines

The IEEE-488 bus uses eight data lines that transfer data one byte at a time. DIO1 (Data Input/Output) through DIO8 (Data Input/Output) are the eight data lines used to transmit both data and multiline commands and are bidirectional. The data lines operate with low true logic.

Bus management lines

The five bus management lines help to ensure proper interface control and management. These lines are used to send the uniline commands.

ATN (Attention) — The ATN line is one of the more important management lines. The state of this line determines how information on the data bus is to be interpreted.

IFC (Interface Clear) — As the name implies, the IFC line controls clearing of instruments from the bus.

REN (Remote Enable) — The REN line is used to place the instrument on the bus in the remote mode.

EOI (End or Identify) — The EOI is usually used to mark the end of a multi-byte data transfer sequence.

SRQ (Service Request) — This line is used by devices when they require service from the controller.

Handshake lines

The bus handshake lines operate in an interlocked sequence. This method ensures reliable data transmission regardless of the transfer rate. Generally, data transfer will occur at a rate determined by the slowest active device on the bus.

One of the three handshake lines is controlled by the source (the talker sending information), while the remaining two lines are controlled by accepting devices (the listener or listeners receiving the information). The three handshake lines are:

DAV (DATA VALID) — The source controls the state of the DAV line to indicate to any listening devices whether or not data bus information is valid.

NRFD (Not Ready For Data) — The acceptor controls the state of NRFD. It is used to signal to the transmitting device to hold off the byte transfer sequence until the accepting device is ready.

NDAC (Not Data Accepted) — NDAC is also controlled by the accepting device. The state of NDAC tells the source whether or not the device has accepted the data byte.

The complete handshake sequence for one data byte is shown in **Figure D-2**. Once data is placed on the data lines, the source checks to see that NRFD is high, indicating that all active devices are ready. At the same time, NDAC should be low from the previous byte transfer. If these conditions are not met, the source must wait until NDAC and NRFD have the correct status. If the source is a controller, NRFD and NDAC must be stable for at least 100nsec after ATN is set true. Because of the possibility of a bus hang up, many controllers have time-out routines that display messages in case the transfer sequence stops for any reason.

Once all NDAC and NRFD are properly set, the source sets DAV low, indicating to accepting devices that the byte on the data lines is now valid. NRFD will then go low, and NDAC will go high once all devices have accepted the data. Each device will release NDAC at its own rate, but NDAC will not be released to go high until all devices have accepted the data byte.

The sequence just described is used to transfer both data, talk and listen addresses, as well as multiline commands. The state of the ATN line determines whether the data bus contains data, addresses or commands as described in the following paragraph.

Figure D-2
IEEE-488 handshake sequence

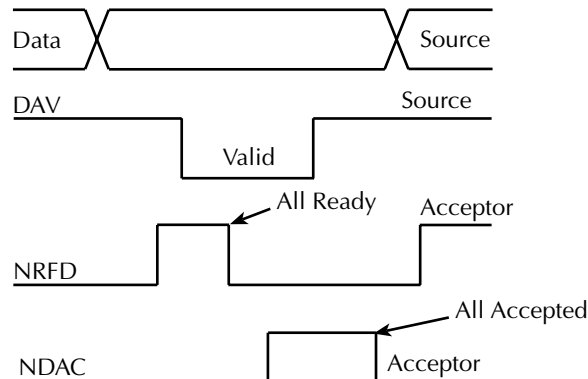

Bus commands

The instrument may be given a number of special bus commands through the IEEE-488 interface. This section briefly describes the purpose of the bus commands which are grouped into the following four categories.

1. **Uniline commands** — Sent by setting the associated bus lines true. For example, to assert REN (Remote Enable), the REN line would be set low (true).
2. **Multiline commands** — General bus commands which are sent over the data lines with the ATN line true (low).
3. **Common commands** — Commands that are common to all devices on the bus; sent with ATN high (false).
4. **SCPI commands** — Commands that are particular to each device on the bus; sent with ATN high (false).

These bus commands and their general purpose are summarized in [Table D-1](#).

Table D-1

IEEE-488 bus command summary

Command type	Command	State of ATN line	Comments
Uniline	REN (Remote Enable)	X	Set up devices for remote operation.
	EOI (End Or Identify)	X	Marks end of transmission.
	IFC (Interface Clear)	X	Clears interface.
	ATN (Attention)	Low	Defines data bus contents.
	SRQ (Service Request)	X	Controlled by external device.
Multiline Universal	LLO (Local Lockout)	Low	Locks out local operation.
	DCL (Device Clear)	Low	Returns device to default conditions.
	SPE (Serial Poll Enable)	Low	Enables serial polling.
	SPD (Serial Poll Disable)	Low	Disables serial polling.
Addressed	SDC (Selective Device Clear)	Low	Returns unit to default conditions.
	GTL (Go To Local)	Low	Returns device to local.
Unaddressed	UNL (Unlisten)	Low	Removes all listeners from the bus.
	UNT (Untalk)	Low	Removes any talkers from the bus.
Common	—	High	Programs IEEE-488.2 compatible instruments for common operations.
SCPI	—	High	Programs SCPI compatible instruments for particular operations.

Uniline commands

ATN, IFC and REN are asserted only by the controller. SRQ is asserted by an external device. EOI may be asserted either by the controller or other devices depending on the direction of data transfer. The following is a description of each command. Each command is sent by setting the corresponding bus line true.

REN (Remote Enable) — REN is sent to set up instruments on the bus for remote operation. When REN is true, devices will be removed from the local mode. Depending on device configuration, all front panel controls except the LOCAL key (if the device is so equipped) may be locked out when REN is true. Generally, REN should be sent before attempting to program instruments over the bus.

EOI (End or Identify) — EOI is used to positively identify the last byte in a multi-byte transfer sequence, thus allowing data words of various lengths to be transmitted easily.

IFC (Interface Clear) — IFC is used to clear the interface and return all devices to the talker and listener idle states.

ATN (Attention) — The controller sends ATN while transmitting addresses or multiline commands.

SRQ (Service Request) — SRQ is asserted by a device when it requires service from a controller.

Universal multiline commands

Universal commands are those multiline commands that require no addressing. All devices equipped to implement such commands will do so simultaneously when the commands are transmitted. As with all multiline commands, these commands are transmitted with ATN true.

LLO (Local Lockout) — LLO is sent to the instrument to lock out the LOCAL key and thus all the front panel controls.

DCL (Device Clear) — DCL is used to return instruments to some default state. Usually, instruments return to the power-up conditions.

SPE (Serial Poll Enable) — SPE is the first step in the serial polling sequences, which is used to determine which device has requested service.

SPD (Serial Poll Disable) — SPD is used by the controller to remove all devices on the bus from the serial poll mode and is generally the last command in the serial polling sequence.

Addressed multiline commands

Addressed commands are multiline commands that must be preceded by the device listen address before that instrument will respond to the command in question. Note that only the addressed device will respond to these commands. Both the commands and the address preceding it are sent with ATN true.

SDC (Selective Device Clear) — The SDC command performs essentially the same function as the DCL command except that only the addressed device responds. Generally, instruments return to their power-up default conditions when responding to the SDC command.

GTL (Go To Local) — The GTL command is used to remove instruments from the remote mode. With some instruments, GTL also unlocks front panel controls if they were previously locked out with the LLO command.

GET (Group Execute Trigger) — The GET command is used to trigger devices to perform a specific action that depends on device configuration (for example, take a reading). Although GET is an addressed command, many devices respond to GET without addressing.

Address commands

Addressed commands include two primary command groups and a secondary address group. ATN is true when these commands are asserted. The commands include:

LAG (Listen Address Group) — These listen commands are derived from an instrument's primary address and are used to address devices to listen. The actual command byte is obtained by ORing the primary address with #H20.

TAG (Talk Address Group) — The talk commands are derived from the primary address by ORing the address with #H40. Talk commands are used to address devices to talk.

SCG (Secondary Command Group) — Commands in this group provide additional addressing capabilities. Many devices (including the Model 2520) do not use these commands.

Unaddress commands

The two unaddress commands are used by the controller to remove any talkers or listeners from the bus. ATN is true when these commands are asserted.

UNL (Unlisten) — Listeners are placed in the listener idle state by the UNL command.

UNT (Untalk) — Any previously commanded talkers will be placed in the talker idle state by the UNT command.

Common commands

Common commands are commands that are common to all devices on the bus. These commands are designated and defined by the IEEE-488.2 standard.

Generally, these commands are sent as one or more ASCII characters that tell the device to perform a common operation, such as reset. The IEEE-488 bus treats these commands as data in that ATN is false when the commands are transmitted.

SCPI commands

SCPI commands are commands that are particular to each device on the bus. These commands are designated by the instrument manufacturer, and are based on the instrument model defined by the Standard Commands for Programmable Instruments (SCPI) Consortium's SCPI standard.

Generally, these commands are sent as one or more ASCII characters that tell the device to perform a particular operation, such as setting a range or closing a relay. The IEEE-488 bus treats these commands as data in that ATN is false when the commands are transmitted.

Command codes

Command codes for the various commands that use the data lines are summarized in [Figure D-3](#). Hexadecimal and the decimal values for the various commands are listed in [Table D-2](#).

Table D-2
Hexadecimal and decimal command codes

Command	Hex value	Decimal value
GTL	01	1
SDC	04	4
GET	08	8
LLO	11	17
DCL	14	20
SPE	18	24
SPD	19	25
LAG	20-3F	32-63
TAG	40-5F	64-95
SCG	60-7F	96-127
UNL	3F	63
UNT	5F	95

Typical command sequences

For the various multiline commands, a specific bus sequence must take place to properly send the command. In particular, the correct listen address must be sent to the instrument before it will respond to addressed commands. [Table D-3](#) lists a typical bus sequence for sending the addressed multiline commands. In this instance, the SDC command is being sent to the instrument. UNL is generally sent as part of the sequence to ensure that no other active listeners are present. Note that ATN is true for both the listen command and the SDC command byte itself.

Table D-3

Typical addressed multiline command sequence

Step	Command	ATN state	Data bus		
			ASCII	Hex	Decimal
1	UNL	Set low	?	3F	63
2	LAG*	Stays low	10	3A	58
3	SDC	Stays low	EOT	04	4
4		Returns high			

*Assumes primary address = 26.

[Table D-4](#) gives a typical common command sequence. In this instance, ATN is true while the instrument is being addressed, but it is set high while sending the common command string.

Table D-4

Typical addressed common command sequence

Step	Command	ATN state	Data bus		
			ASCII	Hex	Decimal
1	UNL	Set low	?	3F	63
2	LAG*	Stays low	10	3A	58
3	Data	Set high	*	2A	42
4	Data	Stays high	R	52	82
5	Data	Stays high	S	53	83
6	Data	Stays high	T	54	84

*Assumes primary address = 26.

IEEE command groups

Command groups supported by the Model 2520 are listed in [Table D-5](#). Common commands and SCPI commands are not included in this list.

Table D-5

IEEE command groups

HANDSHAKE COMMAND GROUP	
	NDAC = NOT DATA ACCEPTED NRFD = NOT READY FOR DATA DAV = DATA VALID
UNIVERSAL COMMAND GROUP	
	ATN = ATTENTION DCL = DEVICE CLEAR IFC = INTERFACE CLEAR REN = REMOTE ENABLE SPD = SERIAL POLL DISABLE SPE = SERIAL POLL ENABLE
ADDRESS COMMAND GROUP	
LISTEN	LAG = LISTEN ADDRESS GROUP MLA = MY LISTEN ADDRESS UNL = UNLISTEN
TALK	TAG = TALK ADDRESS GROUP MTA = MY TALK ADDRESS UNT = UNTALK OTA = OTHER TALK ADDRESS
ADDRESSED COMMAND GROUP	
	ACG = ADDRESSED COMMAND GROUP GTL = GO TO LOCAL SDC = SELECTIVE DEVICE CLEAR
STATUS COMMAND GROUP	
	RQS = REQUEST SERVICE SRQ = SERIAL POLL REQUEST STB = STATUS BYTE EOI = END

Interface function codes

The interface function codes, which are part of the IEEE-488 standards, define an instrument's ability to support various interface functions and should not be confused with programming commands found elsewhere in this manual. The interface function codes for the Model 2520 are listed in [Table D-6](#). The codes define Model 2520 capabilities as follows:

Table D-6

Model 2520 interface function codes

Code	Interface function
SH1	Source Handshake capability
AH1	Acceptor Handshake capability
T5	Talker (basic talker, serial poll, unaddressed to talk on LAG)
L4	Listener (basic listener, unaddressed to listen on TAG)
SR1	Service Request capability
RL1	Remote/Local capability
PP0	No Parallel Poll capability
DC1	Device Clear capability
DT1	Device Trigger capability
C0	No Controller capability
E1	Open collector bus drivers
TE0	No Extended Talker capability
LE0	No Extended Listener capability

SH (Source Handshake Function) — SH1 defines the ability of the instrument to initiate the transfer of message/data over the data bus.

AH (Acceptor Handshake Function) — AH1 defines the ability of the instrument to guarantee proper reception of message/data transmitted over the data bus.

T (Talker Function) — The ability of the instrument to send data over the bus to other devices is provided by the T function. Instrument talker capabilities (T5) exist only after the instrument has been addressed to talk.

L (Listener Function) — The ability for the instrument to receive device-dependent data over the bus from other devices is provided by the L function. Listener capabilities (L4) of the instrument exist only after it has been addressed to listen.

SR (Service Request Function) — SR1 defines the ability of the instrument to request service from the controller.

RL (Remote-Local Function) — RL1 defines the ability of the instrument to be placed in the remote or local modes.

PP (Parallel Poll Function) — The instrument does not have parallel polling capabilities (PP0).

DC (Device Clear Function) — DC1 defines the ability of the instrument to be cleared (initialized).

DT (Device Trigger Function) — DT1 defines the ability of the Model 2520 to have readings triggered.

C (Controller Function) — The instrument does not have controller capabilities (C0).

TE (Extended Talker Function) — The instrument does not have extended talker capabilities (TE0).

LE (Extended Listener Function) — The instrument does not have extended listener capabilities (LE0).

E (Bus Driver Type) — The instrument has open-collector bus drivers (E1).

E IEEE-488 and SCPI Conformance Information

Introduction

The IEEE-488.2 standard requires specific information about how the Model 2520 implements the standard. Paragraph 4.9 of the IEEE-488.2 standard (Std 488.2-1987) lists the documentation requirements. [Table E-1](#) provides a summary of the requirements, and provides the information or references the manual for that information. [Table E-2](#) lists the coupled commands used by the Model 2520.

The Model 2520 complies with SCPI version 1996.0. [Table 14-1](#) through [Table 14-10](#) in [Section 14](#) lists the SCPI confirmed commands and the non-SCPI commands implemented by the Model 2520.

Table E-1
IEEE-488 documentation requirements

	Requirements	Description or reference
(1)	IEEE-488 Interface Function Codes.	See Appendix D .
(2)	Behavior of Model 2520 when the address is set outside the range 0-30.	Cannot enter an invalid address.
(3)	Behavior of Model 2520 when valid address is entered.	Address changes and bus resets.
(4)	Power-On Setup Conditions.	Determine by :SYSTem:POSetup. See Section 14 .
(5)	Message Exchange Options:	
(a)	Input buffer size.	2048 bytes.
(b)	Queries that return more than one response message unit.	None.
(c)	Queries that generate a response when parsed.	All queries (Common Commands and SCPI).
(d)	Queries that generate a response when read.	None.
(e)	Coupled commands.	See Table E-2 .
(6)	Functional elements required for SCPI commands.	Contained in SCPI command sub systems tables (see Table 14-1 through Table 14-10).
(7)	Buffer size limitations for block data.	Block display messages: 32 characters max.
(8)	Syntax restrictions.	See Section 10 , "Programming syntax."
(9)	Response syntax for every query command.	See Section 10 , "Programming syntax."
(10)	Device-to-device message transfer that does not follow rules of the standard.	None.
(11)	Block data response size.	See Section 14 , "FORMat subsystem."
(12)	Common Commands implemented by Model 2520.	See Section 12 , "Common Commands".
(13)	Calibration query information.	See Service Manual.
(14)	Trigger macro for *DDT.	Not applicable.
(15)	Macro information.	Not applicable.
(16)	Response to *IDN (identification).	See Section 12 , "Common Commands."
(17)	Storage area for *PUD and *PUD?.	Not applicable.
(18)	Resource description for *RDT and *RDT?.	Not applicable.
(19)	Effects of *RST, *RCL and *SAV.	See Section 12 , "Common Commands."
(20)	*TST information.	See Section 12 , "Common Commands."
(21)	Status register structure.	See Section 11 , "Status Structure."
(22)	Sequential or overlapped commands.	All are sequential.
(23)	Operation complete messages.	*OPC, *OPC? and *WAI; see Section 12 , "Common Commands."

Table E-2
Coupled commands

Command	Also changes
:SOURce[1]:CURRent:START	:SOURce[1]:CURRent:STEP
	:SOURce[1]:CURRent:CENTer
	:SOURce[1]:CURRent:SPAN
:SOURce[1]:CURRent:STOP	:SOURce[1]:CURRent:STEP
	:SOURce[1]:CURRent:CENTer
	:SOURce[1]:CURRent:SPAN
:SOURce[1]:CURRent:STEP	:SOURce[1]:CURRent:POINts
:SOURce[1]:CURRent:POINts	:SOURce[1]:CURRent:STEP
:SOURce[1]:CURRent:CENTer	:SOURce[1]:CURRent:START
	:SOURce[1]:CURRent:STOP
	:SOURce[1]:CURRent:STEP
:SOURce[1]:CURRent:SPAN	:SOURce[1]:CURRent:START
	:SOURce[1]:CURRent:STOP
	:SOURce[1]:CURRent:STEP
:SOURce[1]:PULSe:WIDTh	;SOURce[1]:PULSe:DELay
	:TRACe:POINts
:SOURce[1]:PULSe:DELay	:SOURce[1]:PULSe:WIDTh
:SOURce[1]:PULSe:TRANsition:STATe	:SOURce[1]:PULSe:WIDTh
REN, GTL	See local and remote transition in Section 10, "Differences: remote vs. local operation."

F

Measurement Considerations

Optimizing laser diode connections

There are several key considerations when making connections to the laser diode:

- Cable length and inductance
- Exposed loop area
- Correct sense lead connections
- Magnetic coupling between sense and current leads

Each of these considerations is discussed in detail below.

Current pulse output circuit model

Figure F-1 shows the Model 2520 current pulse output circuit model. Components include the current source I and voltage clamp V_C (compliance circuit). L is the cable inductance, and the resistance of the laser diode is represented as R_{DUT} .

Figure F-1
Model 2520 pulse output circuit model

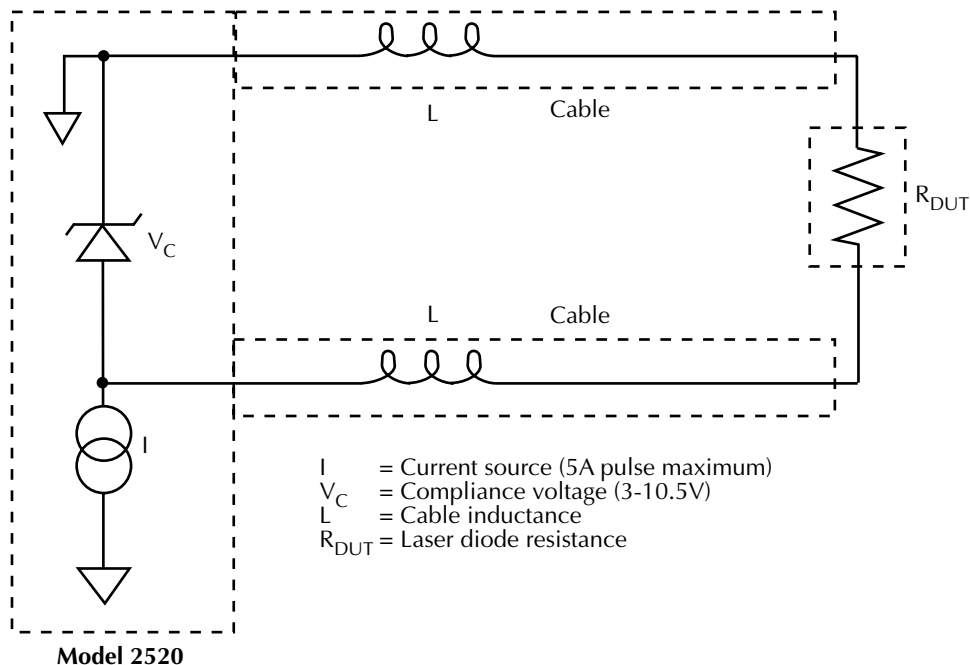

Cable inductance

Under transient conditions, the voltage across the cable inductance is defined as follows:

$$V_L = L \frac{di}{dt}$$

Where: L = total cable inductance
 V_L = voltage across inductance
 di/dt = rate of change of current

For example, the voltage with 100nH of inductance, a 5A current pulse, and 100ns rise time is:

$$V_L = 100\text{nH} \frac{5\text{A}}{100\text{ns}} = 5\text{V}$$

From the above relationship, it is obvious that with excessive inductance, the voltage across the inductance may cause the current source to go into compliance and effectively become a voltage source with a value equal to the compliance setting (10.5V maximum). Under these conditions, voltages in the circuit are related as follows:

$$V_C = L \frac{di}{dt} + IR_{DUT}$$

Current while the source is in compliance then rises according the following relationship:

$$I(t) = \frac{V_C}{R_{DUT}} \left(1 - e^{-\frac{t}{L/R_{DUT}}} \right)$$

From the above discussion, it is obvious that the rise time of the current pulse through the laser diode can be affected by the cable (and other) inductance in the circuit. Thus, it is important to keep cable lengths as short as possible, and use only cables with low inductance such as the supplied CA-290 BNC cables, which have a nominal characteristic impedance of 15Ω and an inductance of 27nH/ft.

A comparison of operating conditions is shown in [Figure F-2](#) and [Figure F-3](#). [Figure F-2](#) shows the settled response for 4A into 1.6Ω using 3m of cable. Inductance is excessive in this case, resulting in the first settled reading at $1.7\mu\text{s}$, as opposed to $1.5\mu\text{s}$ (a $1\mu\text{s}$ delay was used before the pulse).

[Figure F-3](#) shows the settled response of 0.45A into 16Ω , also using 3m of cable. The response is clean because di/dt is much lower.

Figure F-2
Rise time of 4A current pulse

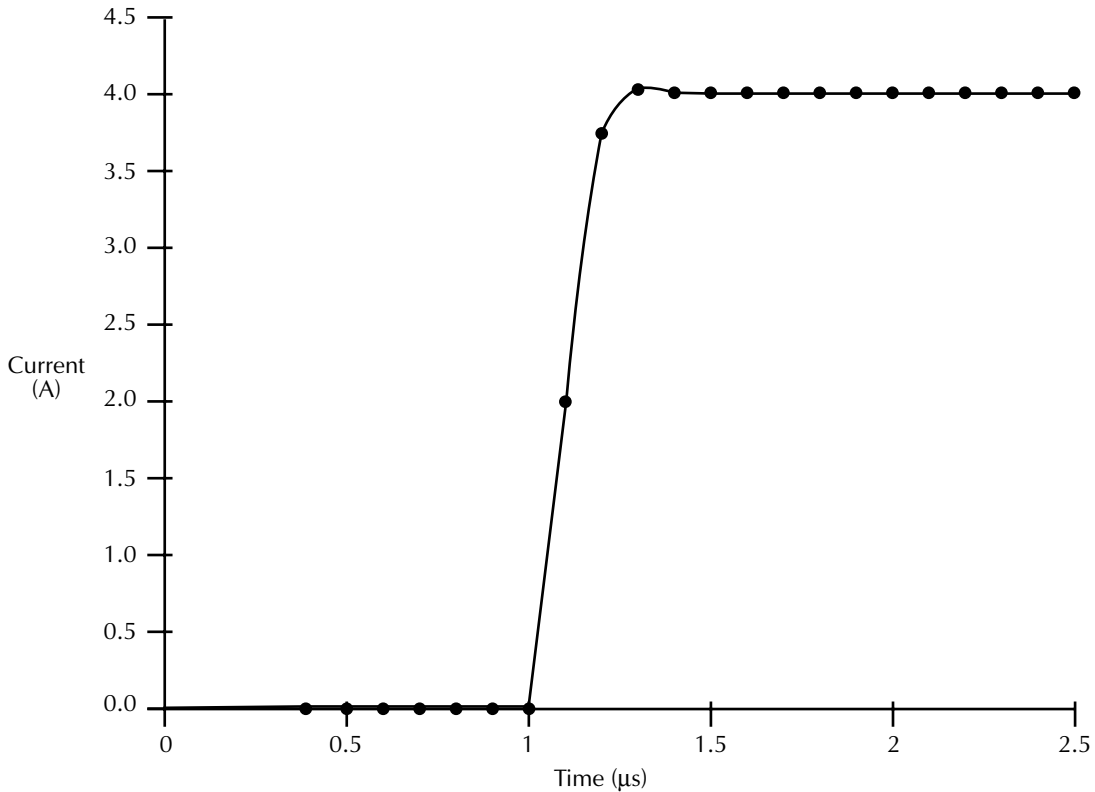
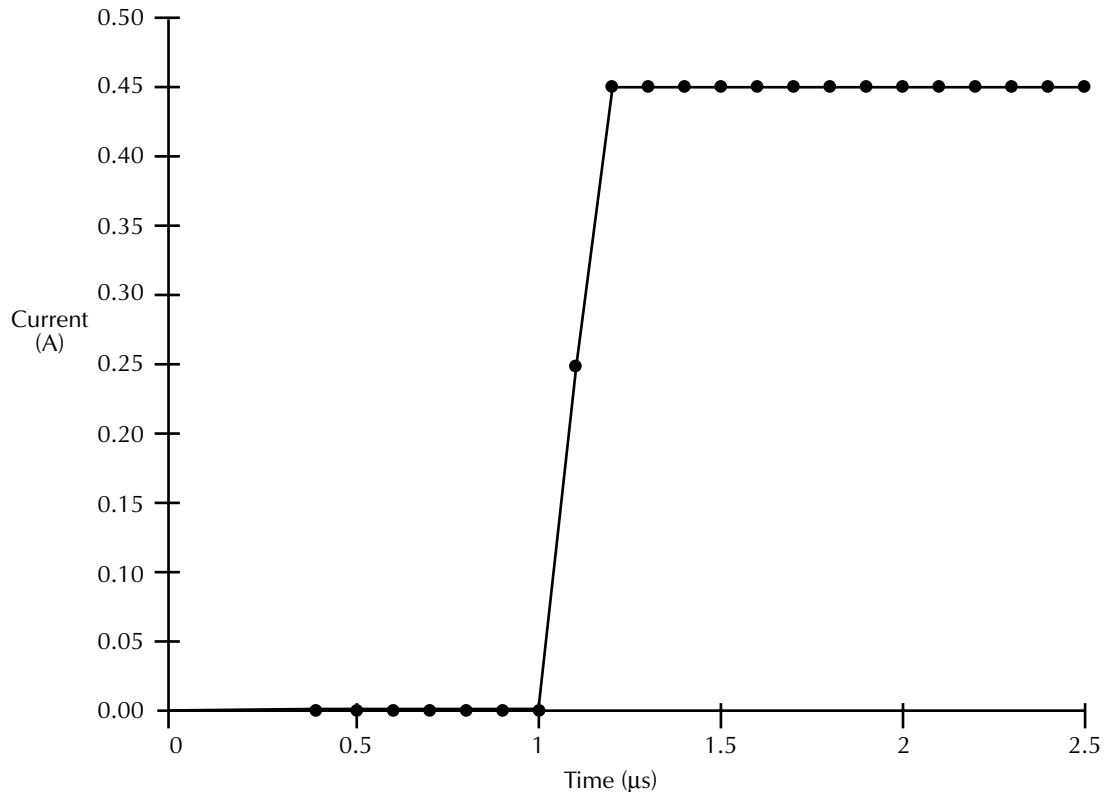

Figure F-3
Rise time of 0.45A current pulse



Increasing cable length

To double the effective recommended cable length without significantly degrading pulse characteristics, connect the laser diode to the CURRENT OUTPUT HI jack only. To use this method, connect one laser diode terminal to the center cable conductor, connect the other terminal to the cable shield, and install a BNC *shorting* cap on the CURRENT OUTPUT LO jack. Select negative current source polarity if the laser diode anode is connected to the center conductor; conversely, select positive current source polarity if the laser diode anode is connected to the shield.

This method decreases rise time because it eliminates one of the two cables that connect the current source to the laser diode, effectively cutting the cable inductance in half. However, the disadvantage is that one terminal of the laser diode is connected to analog common, and you must be careful to properly set the polarity as covered above. Also, this connection method should not be used for the VOLTAGE SENSE terminals.

Exposed loop area

The open loop area (Figure F-4) also affects the rise time of the measurements because of added inductance. With the relatively large open loop area in Figure F-4A, the shields are not carried through to the DUT, and the exposed signal lines form a current loop. This loop effectively increases the inductance and affects the rise time in the same manner as cable inductance outlined above. To minimize the exposed loop area, carry all shields as close to the DUT as possible, as shown in Figure F-4B. Doing so will reduce the distributed inductance and decrease the rise time of the current pulse.

Inductance for a loop of wire X inches by Y inches with a diameter D inches can be calculated as follows:

$$L = 10.16 \times 10^{-9} \left[X \ln \left(2 \frac{Y}{D} \right) + Y \ln \left(2 \frac{X}{D} \right) \right]$$

Thus, a typical 1 inch square loop has an inductance of about 100nH, while a typical 2 inch square loop has an inductance on the order of 170nH.

Figure F-4
Effects of open loop area

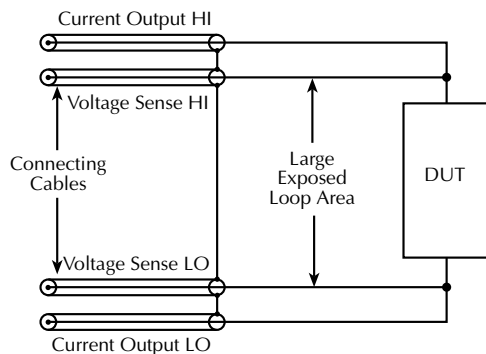

A. Large exposed loop area.

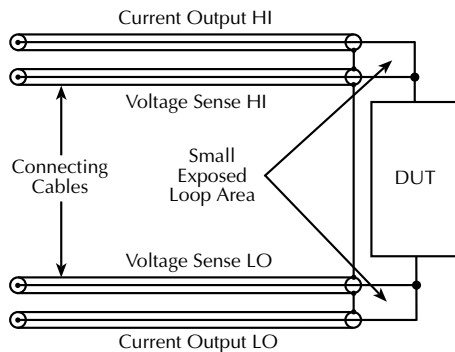

B. Small exposed loop area.

Figure F-5 shows ideal response of a 2A pulse for short (10 inch) properly connected cables. Figure F-6 shows the same setup except for the addition of a two square inch loop in the source connection.

Figure F-5
Ideal response of 2A pulse using 10 inch cables

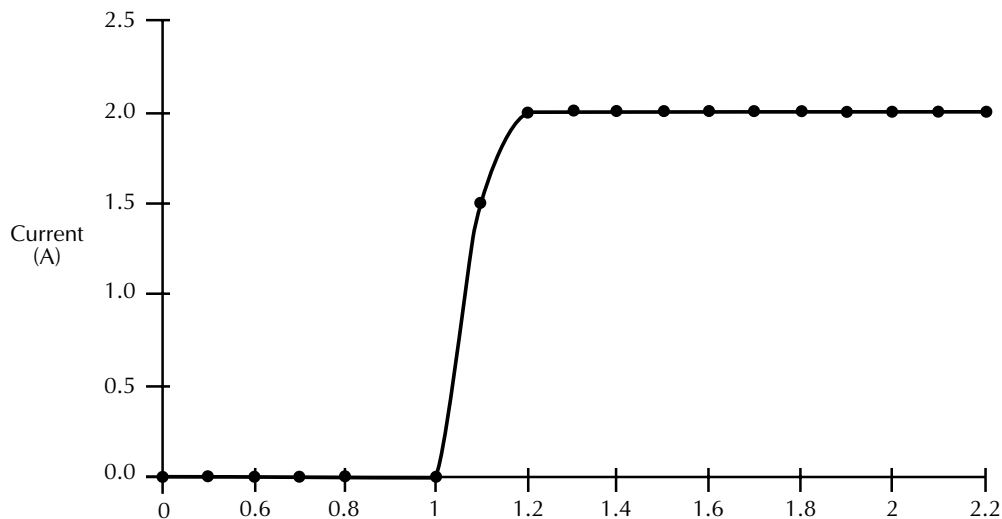
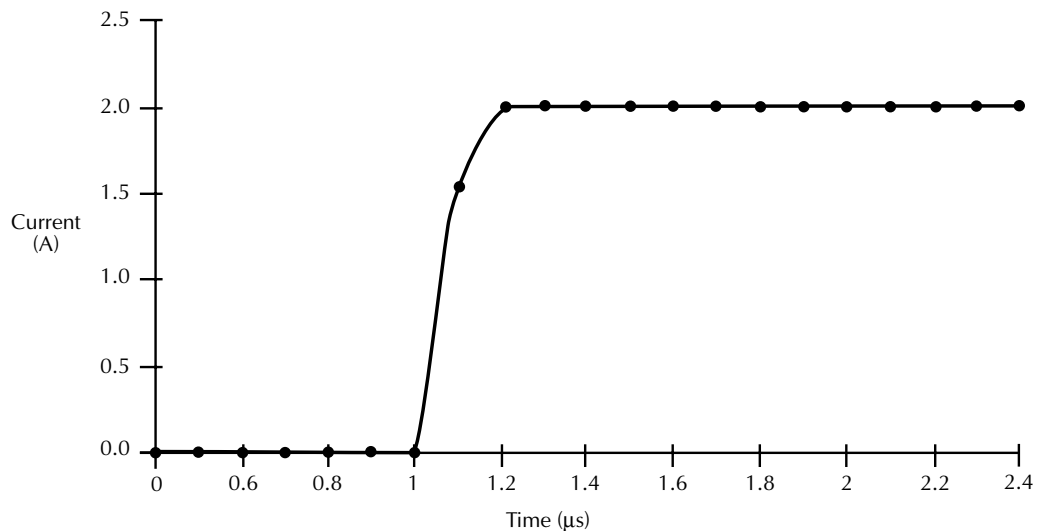

Figure F-6
Response of 2A pulse with two square inch loop



Sense lead connections

Proper sense lead connections to the laser diode are important to good measurements. Figure F-7 shows a comparison of correct and incorrect sense connections. With the incorrect connections shown in Figure F-7A, sense and current leads are not connected together at the DUT. In contrast, the correct connections shown in Figure F-7B show sense connections made separately to the DUT with the sense leads connected as close to the DUT body as possible.

Figure F-7
Sense lead connections

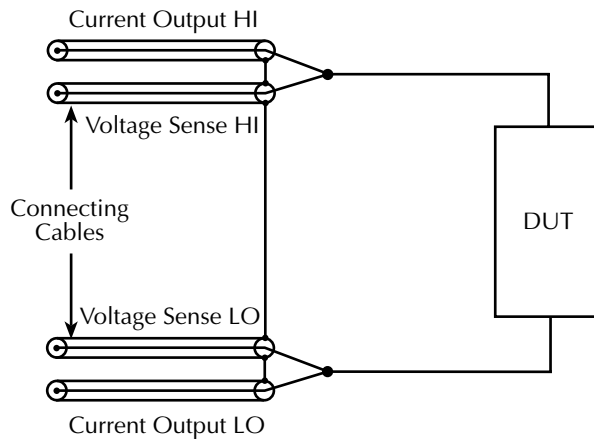

A. Incorrect: sense leads not connected at DUT.

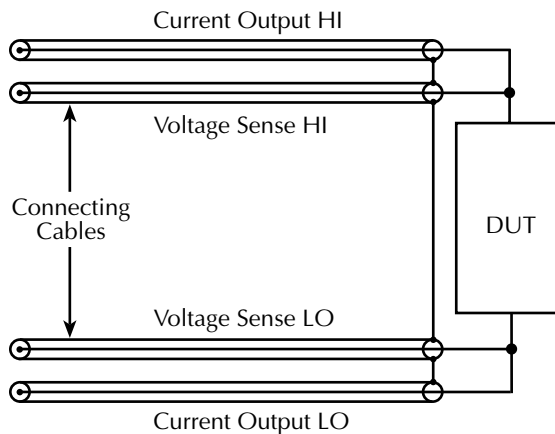

B. Correct: sense leads connected at DUT.

Figure F-8 shows response of a 2A pulse with voltage sense leads 1/4 inch away from the DUT. Note the long settling tail corresponding to the DUT resistance (1.66Ω) and the inductance formed by the leads.

Figure F-8

Response of 2A pulse with sense leads 1/4 inch away from DUT

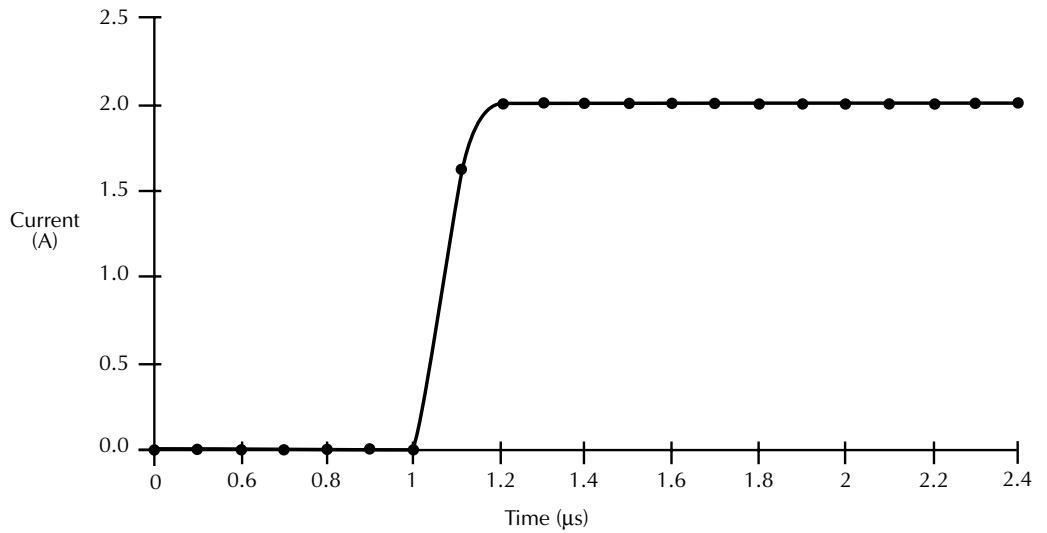

Magnetic coupling

Magnetic coupling between sense and current leads can also affect measurements. Figure F-9A shows connections that will result in considerable coupling due to the relatively long exposed signal lead area. Carrying the sense shields as close to the DUT as possible (Figure F-9B) will reduce magnetic coupling and improve response. Twisting the exposed sense leads and even the cables themselves may be necessary to reduce coupling to an acceptable level.

Figure F-9
Magnetic coupling

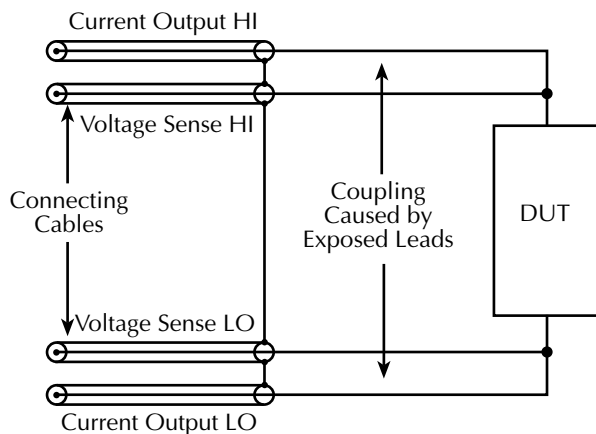

A. Coupling caused by exposed leads.

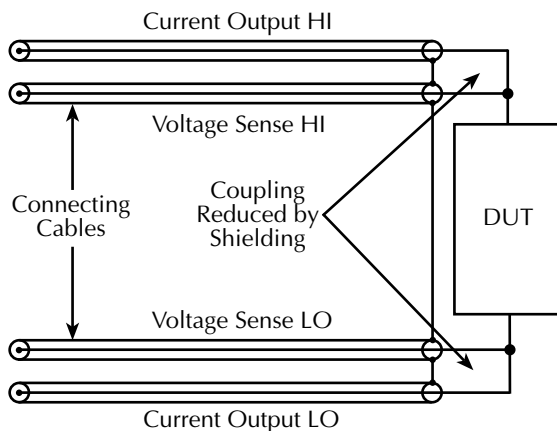

B. Coupling reduced by shielding.

Increasing laser diode pulse measurement speed

Overview

The index of refraction of a given optical media is the ratio of the speed of light in a vacuum divided by the speed of light through the media. As a ray of light passes through optical media of differing indices of refraction, reflections and coupling losses will result. These reflections will act to generate constructive or destructive interference with other reflections and desired wave fronts. These undesired reflections may strongly affect the performance of the optics system. Measures must be taken to prevent the effects of unwanted reflection in an optical system. Optical engineers have developed design methodologies to identify and control the negative side effects of differing indices of refraction while capturing the desired optical mechanisms.

Figure F-10 shows an optical pulse propagating through an optical media of differing indices of refraction. In this example, multiple reflections combine to form a second image of the pulse trailing behind the first. Preventing the reflections would help maintain the fidelity of the original pulse shape.

Figure F-10

Optical pulse propagation through differing indices of refraction

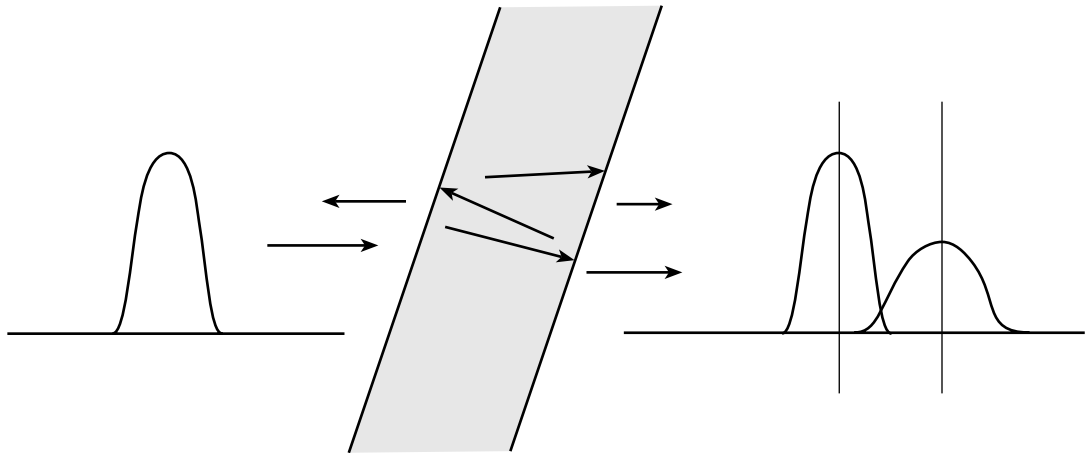

The propagation speed of an electrical current pulse through a conductive material is a function of the material's impedance. Any change in propagation speed as a signal passes between different materials or impedances will result in coupling loss and reflections. As with the optical realm, reflections can result in constructive or destructive interference.

The resulting signal can exceed the desired level or require considerable settling time and impact system integrity. Electrical design engineers have developed techniques to identify and manage impedance mismatches to optimize signal coupling and minimize unwanted reflections. This is fundamental in the application of high-speed pulses to laser diodes during testing. Impedance matching and transmission line effects must be understood and managed to prevent damage or optimize test results.

Laser diode impedance matching

The typical laser diode has a characteristic impedance of 2Ω to 6Ω . This impedance is considerably lower than that of common coaxial cables, which typically have characteristic impedances in the range of 50Ω to 75Ω . Matching a laser diode to the impedance of the coaxial cable would require adding 48Ω to 44Ω of series resistance. However, sourcing a 5A pulse across 50Ω load would generate a 250V potential. Such potentials are not only a safety hazard, but will also damage the laser diode under test.

To enhance impedance matching, low-impedance cables, such as the 15Ω coaxial cables supplied with the Model 2520 should be used. This cable was designed for fast transient high-current response and reduces the mismatch between the laser diode and transmission line.

Model 2520 output circuit model

Figure F-11 shows the Model 2520 pulse output circuit model. There are several unique features of this pulse circuit. The most notable is that the CURRENT OUTPUT HI terminal provides a path to analog ground while the CURRENT OUTPUT LO terminal sinks the current during the pulse. The OUTPUT HI terminal also has a high-frequency path to chassis ground. While the current flows from the HI to the LO terminal, the HI terminal is at ground potential and would be used as the reference ground while connecting an oscilloscope to verify the forward voltage signal across the laser diode under test.

Figure F-11
Model 2520 output circuit model

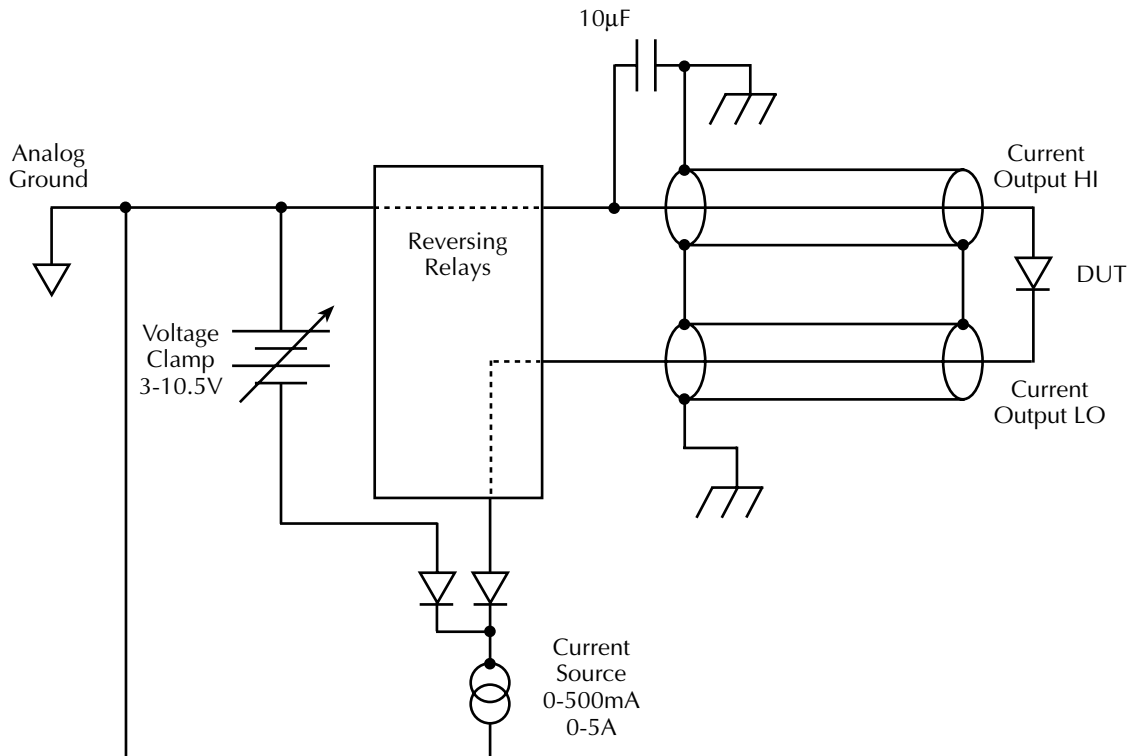

The voltage clamp circuit acts to limit maximum voltage as seen by the output of the pulse circuit. Since the clamp circuit is not directly across the laser diode, the voltage drop across the transmission line connected between the pulse source and the laser diode is not seen by the clamp circuit and cannot be regulated by the clamp. As a result, care must be taken to minimize the negative effects of the transmission line.

Transmission line model

Figure F-12 shows the transmission line scheme that provides the least impedance mismatch. The laser diode appears as a low-impedance path to a current pulse. By placing the laser diode in series with the source and termination of the current pulse, and by maintaining uniform impedance in the current path, the magnitude of reflections is minimized. This method, however, is not practical. The electrical shielding must be compromised to provide access to the laser diode as shown in Figure F-13.

The compromised shield provides access to the laser diode and upsets the continuity of the impedance of the transmission line. To minimize the effects of the discontinuity, the shield of the two compromised cable sections must be connected and the length of the inner conductor must be minimized.

Figure F-12

Minimal impedance mismatch

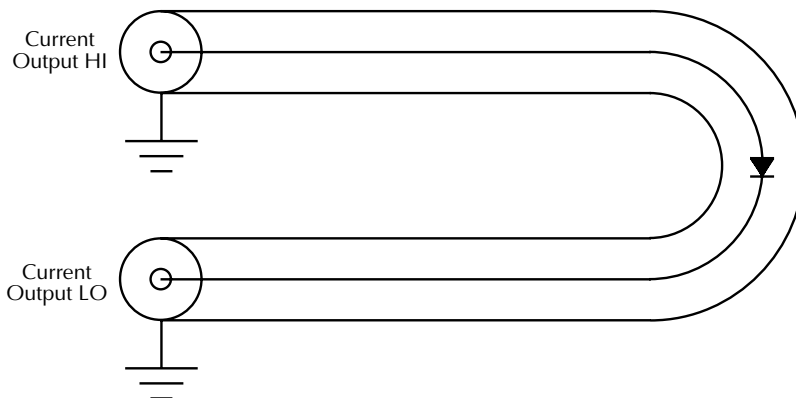
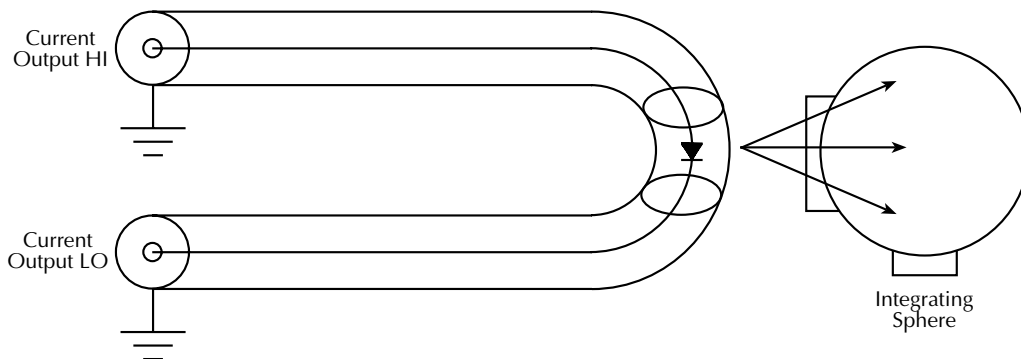

Figure F-13

Compromised shield provides laser diode access



Forward voltage measurement

Figure F-14 shows the model of the Model 2520 voltage measurement channel. This circuit has been optimized to capture the forward voltage drop across the laser diode while minimizing the impact to the laser diode under test.

Figure F-15 shows the recommended cable connections for pulse sourcing and forward voltage measurement. Note that all shields are connected together at the laser diode. This scheme provides the minimal impedance mismatch and shortest electrical length for the pulse transmission path.

Figure F-14
Voltage measurement circuit model

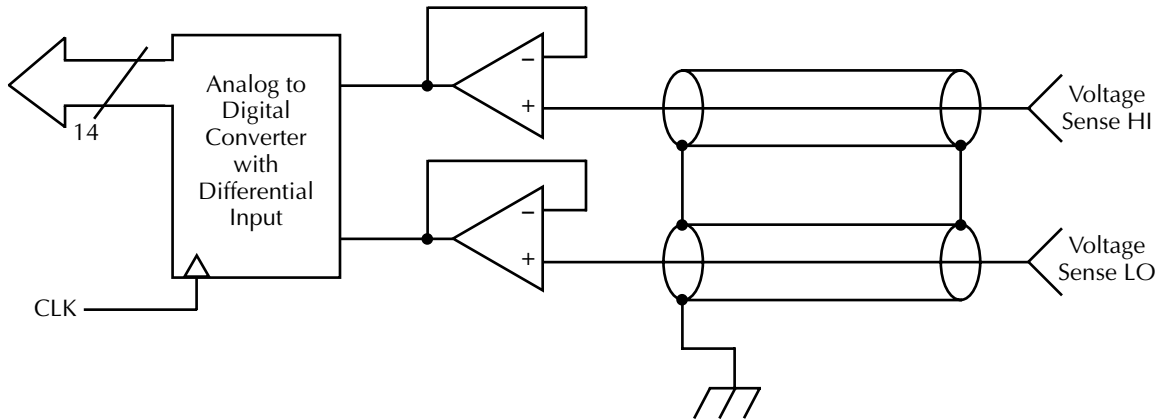
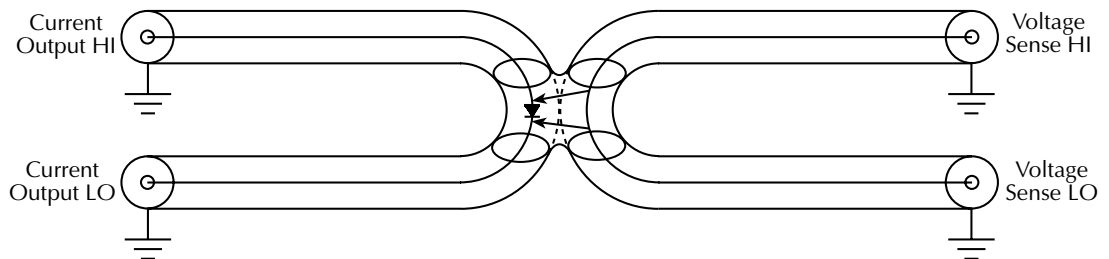

Figure F-15
Pulse source and forward voltage cable interconnections



Photodiode current measurement channels

Figure F-16 shows the circuit model for the dual photodiode current measurement channels. Note that the bias circuit provides the bias voltage via the inner shield of the triax cable. To minimize measurement error caused by noise and extraneous currents, use only low-noise triaxial cables. See “Generated currents,” page F-18, for more information.

Figure F-16

Model 2520 photo current measurement channels with dual bias supplies

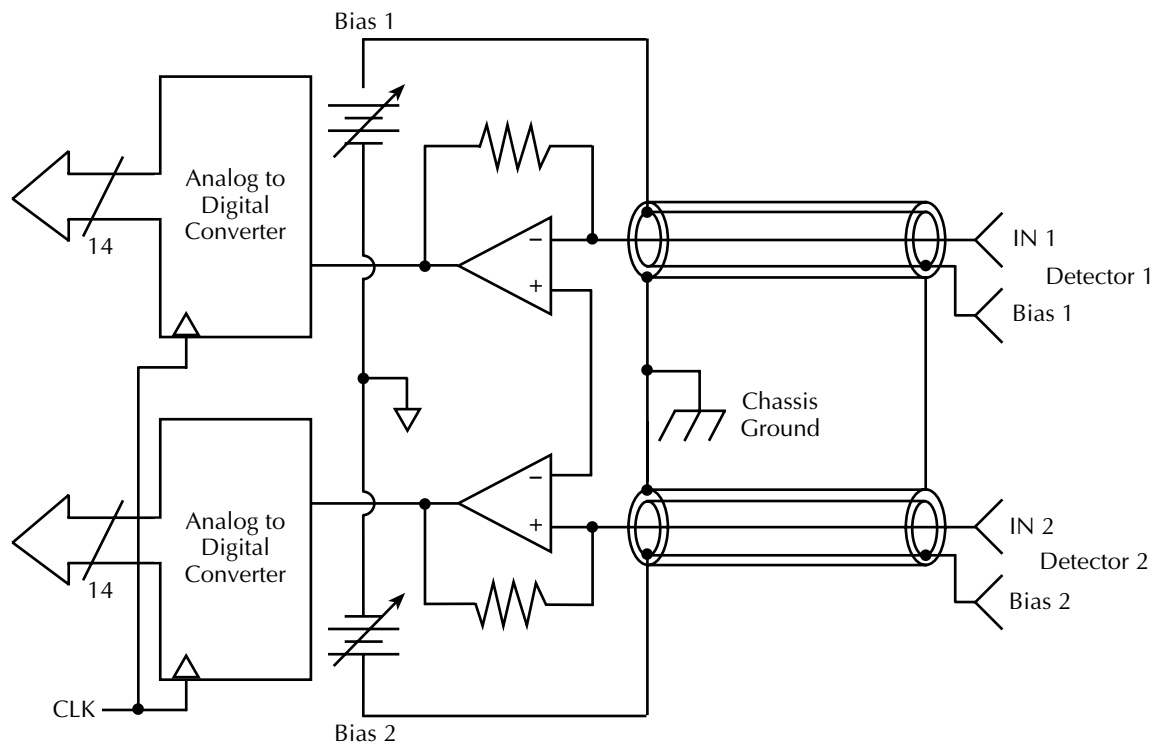

Noise and source impedance

Noise can seriously affect sensitive current measurements. This section discusses how DUT (device under test) resistance and capacitance affect noise performance.

DUT resistance

The resistance of the DUT will affect the noise performance of the ammeters. As the DUT resistance is reduced, the noise gain of the ammeter will increase. Noise gain can be given by the following equation:

$$\text{Output } V_{\text{NOISE}} = \text{Input } V_{\text{NOISE}} (1 + R_F/R_{\text{DUT}})$$

where:

- Output V_{NOISE} is noise seen at the output of the ammeter.
- Input V_{NOISE} is the noise seen at the input of the ammeter.
- R_F is the internal feedback resistance for the ammeter.
- R_{DUT} is the resistance of the DUT.

Table F-1 summarizes minimum recommended source resistance values for various measurement ranges for the Model 2520 ammeters. Note that the recommended source resistance varies by measurement range because the R_F value also depends on the measurement range.

Table F-1

Minimum recommended source resistance values

I-measure range	Minimum recommended source resistance
10mA and 20mA	250Ω
50mA and 100mA	50Ω

Source capacitance

DUT source capacitance will also affect the noise performance of the Model 2520 ammeters. In general, as source capacitance increases, the noise gain also increases.

The elements of interest for this discussion are the capacitance (C_{DUT}) of the DUT and the internal feedback capacitance (C_F) for the ammeter. Taking into account the capacitive reactance of these two elements, our previous noise gain formula must be modified as follows:

$$\text{Output } V_{NOISE} = \text{Input } V_{NOISE} (1 + Z_F/Z_{DUT})$$

where:

- Output V_{NOISE} is the noise seen at the output of the ammeter.
- Input V_{NOISE} is the noise seen at the input of the ammeter.
- Z_F is the internal feedback impedance for the ammeter that is formed by C_F and R_F .
- Z_{DUT} is the internal impedance of the DUT that is formed by C_{DUT} and R_{DUT} .

Furthermore,

$$Z_F = \frac{R_F}{\sqrt{(2\pi f R_F C_F)^2 + 1}}$$

and

$$Z_{DUT} = \frac{R_S}{\sqrt{(2\pi f R_S C_S)^2 + 1}}$$

Note that as C_S increases in value, Z_{DUT} decreases in value, thereby increasing the noise gain. Again, at the point where $Z_{DUT} = Z_F$, the input noise is amplified by a factor of two.

High source capacitance can also cause overshoot ringing, and in the extreme, oscillation of the feedback ammeter. Whenever possible, use low-capacitance photodiodes and short cables.

Generated currents

Any extraneous generated currents in the test system will add to the measured detector current, causing errors. Currents can be internally generated, as in the case of instrument input offset current, or they can come from external sources such as insulators, cables, and leaky photodiodes.

Offset currents

Internal offset current — The ideal ammeter should read zero when its input terminals are left open. Practical ammeters, such as those in the Model 2520, do have some small current that flows when the input is open. This current is known as the input offset current, and it is caused by bias currents of active devices as well as by leakage currents through insulators within the instrument.

The internal input offset current adds to the photodiode detector current so that the meter measures the sum of the two currents:

$$I_M = I_{PD} + I_{I0}$$

where: I_M is the measured current.

I_{PD} is the photodiode current.

I_{I0} is the internal input offset current.

The offset current of the Model 2520 is sufficiently low so as to be negligible in most measurement situations. Use the lowest measurement range possible to minimize offset current effects.

External offset current — Offset currents can also be generated from external effects. The external offset current also adds to the desired current, and the ammeter again measures the sum of the currents:

$$I_M = I_{PD} + I_{I0} + I_{EO}$$

where: I_{EO} is the external offset current.

The two main sources for external offset currents are leaky photodiodes and increased photodiode leakage current caused by bias voltage. Generally, lower voltage bias values result in lower photodiode leakage currents.

Dielectric absorption

Dielectric absorption in an insulator can occur when a voltage across that insulator causes positive and negative charges within the insulator to polarize because various polar molecules relax at different rates. When the voltage is removed, the separated charges generate a decaying current through circuits connected to the insulator as they recombine.

To minimize the effects of dielectric absorption on current measurements, avoid applying voltages greater than a few volts to insulators being used for sensitive current measurements. In cases where this practice is unavoidable, it may take minutes or even hours in some cases for the current caused by dielectric absorption to dissipate.

Voltage burden

The input resistance of the ammeter causes a small voltage drop across the input terminals. This voltage is known as the voltage burden and it can cause measurement errors. Refer to [Figure F-17](#) to see how voltage burden affects detector current measurements. Note that voltage burden (V_B) reduces the measured current (I_M) due to the effects of the ammeter input resistance (R_{IN}).

Figure F-17
Voltage burden

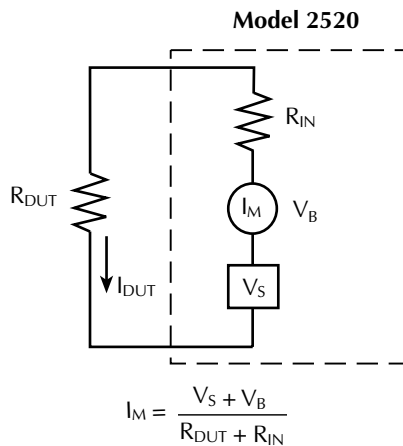

General measurement considerations

The following measurement considerations apply to all precision measurements.

Ground loops

Ground loops that occur in multiple-instrument test setups can create error signals that cause erratic or erroneous measurements. The configuration shown in [Figure F-18](#) introduces errors in two ways. Large ground currents flowing in one of the wires will encounter small resistances, either in the wires, or at the connecting points. This small resistance results in voltage drops that can affect the measurement. Even if the ground loop currents are small, magnetic flux cutting across the large loops formed by the ground leads can induce sufficient voltages to disturb sensitive measurements.

To prevent ground loops, instruments should be connected to ground at only a single point, as shown in [Figure F-19](#). Note that only a single instrument is connected directly to power line ground. Experimentation is the best way to determine an acceptable arrangement. For

this purpose, measuring instruments should be placed on their lowest ranges. The configuration that results in the lowest noise signal is the one that should be used.

Figure F-18
Eliminating ground loops

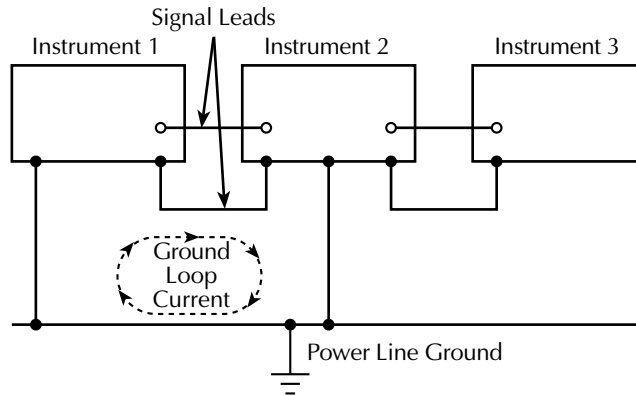
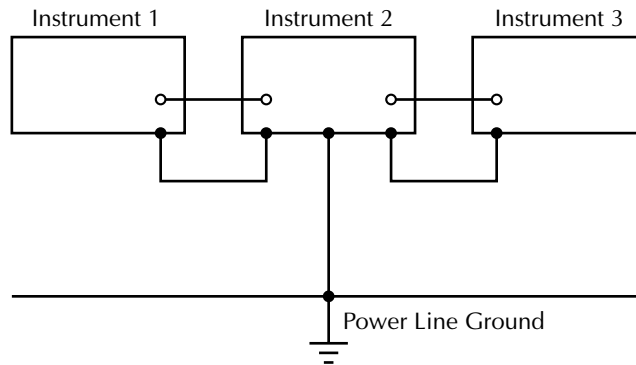

Figure F-19
Power line ground loops



Light

Some components, such as semiconductor junctions and MOS capacitors on semiconductor wafers, are excellent light detectors. Consequently, these components must be tested in a light-free environment. While many test fixtures provide adequate light protection, others may allow sufficient light penetration to affect the test results. Areas to check for light leaks include doors and door hinges, tubing entry points, and connectors or connector panels.

Electrostatic interference

Electrostatic interference occurs when an electrically charged object is brought near an uncharged object, thus inducing a charge on the previously uncharged object. Usually, effects of such electrostatic action are not noticeable because low impedance levels allow the induced charge to dissipate quickly. However, the high impedance levels of many measurements do not allow these charges to decay rapidly, and erroneous or unstable readings may result. These erroneous or unstable readings may be caused in the following ways:

- DC electrostatic field can cause undetected errors or noise in the reading.
- AC electrostatic fields can cause errors by driving the input preamplifier into saturation, or through rectification that produces DC errors.

Electrostatic interference is first recognizable when hand or body movements near the experiment cause fluctuations in the reading. Means of minimizing electrostatic interference include:

1. **Shielding.** Possibilities include: a shielded room, a shielded booth, shielding the sensitive circuit, and using shielded cable. The shield should always be connected to a solid connector that is connected to signal low. If circuit low is floated above ground, observe safety precautions, and avoid touching the shield. Meshed screen or loosely braided cable could be inadequate for high impedances, or in strong fields. Note, however, that shielding can increase capacitance in the measuring circuit, possibly slowing down response time.
2. **Reduction of electrostatic fields.** Moving power lines or other sources away from the experiment reduces the amount of electrostatic interference seen in the measurement.

Magnetic fields

A magnetic field passing through a loop in a test circuit will generate a magnetic EMF (voltage) that is proportional to the strength of the field, the loop area, and the rate at which these factors are changing. Magnetic fields can be minimized by following these guidelines:

- Locate the test circuit as far away as possible from such magnetic field sources as motors, transformers and magnets.
- Avoid moving any part of the test circuit within the magnetic field.
- Minimize the loop area by keeping leads as short as possible and twisting them together.

Electromagnetic Interference (EMI)

The electromagnetic interference characteristics of the Model 2520 comply with the electromagnetic compatibility (EMC) requirements of the European Union as denoted by the CE mark. However, it is still possible for sensitive measurements to be affected by external sources. In these instances, special precautions may be required in the measurement setup.

Sources of EMI include:

- Radio and TV broadcast transmitters.
- Communications transmitters, including cellular phones and handheld radios.
- Devices incorporating microprocessors and high-speed digital circuits.
- Impulse sources as in the case of arcing in high-voltage environments.

The effect on instrument performance can be considerable if enough of the unwanted signal is present. The effects of EMI can be seen as an unusually large offset, or, in the case of impulse sources, erratic variations in the displayed reading.

The instrument and experiment should be kept as far away as possible from any EMI sources. Additional shielding of the instrument, experiment and test leads will often reduce EMI to an acceptable level. In extreme cases, a specially constructed screen room may be required to sufficiently attenuate the troublesome signal.

External filtering of the input signal path may be required. In some cases, a simple one-pole filter may be sufficient. In more difficult situations, multiple notch or band-stop filters, tuned to the offending frequency range, may be required. Connecting multiple capacitors of widely different values in parallel will maintain a low impedance across a wide frequency range. Keep in mind, however, that such filtering may have detrimental effects (such as increased response time) on the measurement.

G GPIB 488.1 Protocol

Introduction

The Model 2520 supports two GPIB protocols: SCPI and 488.1. The 488.1 protocol is included to significantly increase speed over the GPIB.

When using the 488.1 protocol, throughput is enhanced up to 10 times for data sent to the Model 2520 (command messages) and up to 20 times for data returned by the Model 2520 (response messages). The speed of readings sent over the GPIB is also increased.

***NOTE** With the 488.1 protocol selected, you will still use SCPI commands to program the Model 2520. Operation differences between the two protocols are discussed in this appendix.*

Selecting the 488.1 protocol

Perform the following steps to select the 488.1 protocol:

1. Press the COMM key to display the COMMUNICATIONS SETUP menu.
2. Place the cursor on GPIB, then press ENTER.
3. Press ENTER at the ADDRESS prompt to display the GPIB PROTOCOL menu.
4. Place the cursor on 488.1, and press ENTER.
5. Use the EXIT key to back out of the menu structure.

When switching between the SCPI protocol and 488.1 protocol, the instrument does not reset. The GPIB protocol setting is saved in EEPROM, and the unit will power up with that selected protocol.

The GPIB protocol cannot be changed over the bus. However, there is a query command to determine the presently selected protocol. When the 488.1 protocol is selected, the message exchange protocol (MEP) disables. Therefore, if you use the following query to request the state of MEP, you will know which protocol is enabled:

```
:SYSTem:MEP[:STATe]?
```

If a "1" is returned, MEP is enabled, and the SCPI protocol is selected. A "0" indicates that MEP is disabled, and the 488.1 protocol is enabled. To summarize:

1 = SCPI protocol

0 = 488.1 protocol

Protocol differences

The following information covers the differences between the 488.1 protocol and the SCPI protocol.

Message exchange protocol (MEP)

When the 488.1 protocol is selected, the MEP is disabled to speed up GPIB operation.

The following guidelines/limitations must be followed when using the 488.1 protocol:

- If a query is sent, it must be the only command on the line (this limitation also means no multiple queries can be sent). Otherwise, full SCPI command syntax is still supported including long-form and short form commands, multiple commands, and MIN/MAX/DEF parameter definitions.

For example, the following command strings are invalid:

```
:SENS1:VOLT:RANG 10;*OPC?
```

```
:SENS2:CURR:RANG?;;READ?
```

```
:READ?;;READ?
```

The following command strings are valid:

```
:SOUR1:CURREnt:STARt 0.1;STOP 0.5;STEP 0.1
```

```
:SENS2:CURR:RANG? MAX
```

```
:READ?
```

- When a query is sent, either the data must be read back or a Device Clear (DCL) or Interface Clear (IFC) must be performed to reset the query.
- When sending a command or query, do not attempt to read data from the Model 2520 until the terminator has been sent (usually Line Feed with EOI). Otherwise, a DCL or IFC must be sent to reset the input parser.
- When receiving data, all data, up to and including the terminator (LF with EOI), must be accepted. Otherwise, a DCL or IFC must be sent to reset the output task.
- Empty command strings (terminator only) should not be sent.

Using SCPI-based programs

In general, an existing SCPI-based program will run properly and faster in the 488.1 protocol as long as it meets the above guidelines and limitations.

Bus hold-off

*OPC, *OPC?, and *WAI are still functional but are not needed for the 488.1 protocol. When sending commands, the GPIB is automatically held off when it detects a terminator. The hold-off is released when all the commands have finished executing, or if there is some parser or command error. An exception is an initiate command, which releases the hold-off immediately and does not wait for all of the readings to be acquired. This immediate release of bus hold-off is done to support GET, SDC, IFC, *TRG, *RCL, *RST, SYSTem:PRESet and ABORt during data acquisition.

Trigger-on-talk

Trigger-on-talk functionality has been added for the 488.1 protocol. If a query has not been received by the instrument, the Model 2520 will automatically assume a READ? command has been sent when it is addressed to talk. This technique increases GPIB speed by decreasing the transmission and parser times for the command.

Trigger-on-talk is extremely useful in the single-shot reading mode (*RST default) and is the main reason for a >2x speed improvement over the SCPI protocol. Remember that the outputs must be on (:OUTput[1]:STATe ON) before you can take readings.

The TRIG:SOUR BUS and TRIG:COUN INF commands are not supported by READ? with the 488.1 protocol selected. If you send one of these commands, a DCL or IFC may be required to reset the GPIB.

Message available

The MAV (message available) bit in the Serial Poll byte will be set when the query is finished being processed, not when there is data available in the output buffer (as with the SCPI protocol). For the 488.1 protocol, output data will not be formatted until the first request for data is received. This delay may cause unexpected time-outs when using SRQ on MAV for queries that take a long time to execute.

General operation notes

- The TALK, LSTN, and SRQ annunciators are not functional in the 488.1 protocol. This speeds up data throughput greatly. The REM annunciator still operates since it is critical to fundamental GPIB operation.
- If the unit is in REMote, the GTL command may not put the Model 2520 into the local mode. Only the front panel LOCAL key is guaranteed to operate, if not in local lockout (LLO). GTL will still disable LLO.
- IEEE-488 bus commands and features (GET, IFC, SDC, DCL, LLO, Serial Poll, and SRQ) are still fully supported.
- Multiple TALKs on the same query are supported as in the SCPI protocol. This feature is useful when reading back long ASCII strings.

H Example Programs

Introduction

This section provides several complete functional listings; for example, programs throughout this manual. These programs include:

- Laser diode test program from [Section 4](#).
- Linear staircase sweep program from [Section 7](#).
- List (custom) sweep program from [Section 7](#).

Hardware requirements

The following computer hardware is required to run the example programs:

- IBM PC compatible computer.
- Keithley KPC-488.2, KPS-488.2, or KPC-488.2AT, or CEC PC-488 IEEE-488 interface for the computer.
- Shielded IEEE-488 connecting cable (Keithley Model 7007).

Software requirements

In order to use the example programs, you will need the following computer software:

- Microsoft QBasic (supplied with MS-DOS 5.0 or later) or Quick Basic.
- MS-DOS version 5.0 or later or Windows 95/98.
- HP-style Universal Language Driver, CECHP.EXE (supplied with Keithley and CEC interface cards listed above).

General program instructions

1. With the power off, connect the Model 2520 to the IEEE-488 interface of the computer. Be sure to use a shielded IEEE-488 cable for bus connections.
2. Turn on the computer and the Model 2520.
3. Make sure the Model 2520 is set for its default primary address of 25. (Use the front panel COMM key to check or change the address.)
4. Make sure that the computer IEEE-488 bus driver software (CECHP.EXE) is properly initialized.
5. Enter the Basic editor and type in the desired program.
6. Check thoroughly for errors, then save it using a convenient filename.
7. Run the program and note any display messages and data on the screen.

NOTE *Interlocks must be enabled, and laser diode and photodiode connections must be made. See [Section 2](#).*

Laser diode test program

The program listing below performs laser diode testing as covered in [Section 4](#). This program sets up the following operating modes:

- Laser diode measurement: 10V range, power math function.
- Laser diode source range and amplitude: 500mA.
- Laser diode pulse delay, width: 200 μ s, 10 μ s.
- Detector #1, detector #2 source values: 10V, 20V.

```
' Laser diode test program.
' 2520 primary address = 25.
OPEN "IEEE" FOR OUTPUT AS #1          ' Open IEEE-488 output path.
OPEN "IEEE" FOR INPUT AS #2          ' Open IEEE-488 input path.
PRINT #1, "INTERM CRLF"              ' Set input terminator.
PRINT #1, "OUTTERM LF"               ' Set output terminator.
PRINT #1, "REMOTE 25"                ' Put 2520 in remote.
PRINT #1, "OUTPUT 25;*RST"           ' Restore GPIB defaults.
PRINT #1, "OUTPUT 25;;SENS1:VOLT:RANG 10" ' 10V LD measure range.
PRINT #1, "OUTPUT 25;;SENS1:VOLT:POL POS" ' Positive LD measure polarity.
PRINT #1, "OUTPUT 25;;SENS2:CURR:POL NEG" ' Negative D 1 measure polarity.
PRINT #1, "OUTPUT 25;;SENS3:CURR:POL NEG" ' Negative D 2 measure polarity.
PRINT #1, "OUTPUT 25;;FORM:ELEM CURR3" ' Detector 2 current data.
PRINT #1, "OUTPUT 25;;SOUR1:CURR:RANG 0.5" ' 500mA LD source range.
PRINT #1, "OUTPUT 25;;SOUR1:CURR 0.5" ' 500mA LD source current.
PRINT #1, "OUTPUT 25;;SOUR1:VOLT:PROT 5" ' 5V LD source limit.
PRINT #1, "OUTPUT 25;;SOUR1:CURR:POL POS" ' Positive LD polarity.
PRINT #1, "OUTPUT 25;;SOUR1:FUNC PULS" ' LD source pulse mode.
PRINT #1, "OUTPUT 25;;SOUR1:PULS:DEL 100e-6" ' 100us pulse delay.
PRINT #1, "OUTPUT 25;;SOUR1:PULS:WIDT 10e-6" ' 10us pulse width.
PRINT #1, "OUTPUT 25;;SOUR1:CURR:LOW 10e-3" ' 10mA low pulse level.
PRINT #1, "OUTPUT 25;;SOUR2:VOLT 20" ' 20V detector 1 bias voltage.
PRINT #1, "OUTPUT 25;;SOUR3:VOLT 10" ' 10V detector 2 bias voltage.
PRINT #1, "OUTPUT 25;;CALC1:FORM POWER1" ' LD power math.
PRINT #1, "OUTPUT 25;;CALC2:KMAT:MBF 2" ' Detector 1 MX + B B value= 2.
PRINT #1, "OUTPUT 25;;CALC2:KMAT:MMF 0.5" ' Detector 1 MX + B M value = 0.5.
PRINT #1, "OUTPUT 25;;CALC1:STAT ON" ' Enable laser diode math.
PRINT #1, "OUTPUT 25;;CALC2:STAT ON" ' Enable detector 1 math.
PRINT #1, "OUTPUT 25;;OUTP1 ON" ' Turn on outputs.
CLS
PRINT #1, "OUTPUT 25;;READ?"          ' Trigger and read current data.
PRINT #1, "ENTER 25"                 ' Address 2520 to talk.
LINE INPUT #2, R$                    ' Input detector 2 current reading.
PRINT "Detector 2 current measurement: "; R$
PRINT #1, "OUTPUT 25;;CALC1:DATA?"    ' Read laser diode power data.
PRINT #1, "ENTER 25"                 ' Address 2520 to talk.
LINE INPUT #2, R$                    ' Input laser diode math reading.
PRINT "Laser diode power measurement: "; R$
PRINT #1, "OUTPUT 25;;CALC2:DATA?"    ' Read detector 1 MX + B data.
PRINT #1, "ENTER 25"                 ' Address 2520 to talk.
LINE INPUT #2, R$                    ' Input detector 1 math reading.
PRINT "Detector 1 MX + B measurement: "; R$
PRINT #1, "OUTPUT 25;;OUTP1 OFF"      ' Turn off outputs.
END
```

Linear staircase sweep program

The program listing below performs a linear sweep as covered in [Section 7](#). This program sets up the following operating modes:

- Measure range: 5V
- Source mode: sweep
- Source current range: 500mA
- Start current: 10mA
- Stop current: 100mA
- Step current: 10mA
- Detector bias voltages: 5V

```
' Linear staircase sweep program.
' 2520 primary address = 25.
OPEN "IEEE" FOR OUTPUT AS #1           ' Open IEEE-488 output path.
OPEN "IEEE" FOR INPUT AS #2           ' Open IEEE-488 input path.
PRINT #1, "INTERM CRLF"                ' Set input terminator.
PRINT #1, "OUTTERM LF"                 ' Set output terminator.
PRINT #1, "REMOTE 25"                  ' Put 2520 in remote.
PRINT #1, "OUTPUT 25;*RST"             ' Restore GPIB defaults.
PRINT #1, "OUTPUT 25;:FORM:ELEM VOLT1,CURR2,CURR3" ' Voltage/current data.
PRINT #1, "OUTPUT 25;:SENS1:VOLT:RANG 5" ' 5V measure range.
PRINT #1, "OUTPUT 25;:SOUR1:CURR:RANG 0.5" ' 500mA source range.
PRINT #1, "OUTPUT 25;:SOUR1:CURR:STAR 10e-3" ' 10mA start current.
PRINT #1, "OUTPUT 25;:SOUR1:CURR:STOP 100e-3" ' 100mA stop current.
PRINT #1, "OUTPUT 25;:SOUR1:CURR:STEP 10e-3" ' 10mA step current.
PRINT #1, "OUTPUT 25;:SOUR1:CURR:MODE SWE" ' Staircase sweep mode.
PRINT #1, "OUTPUT 25;:SOUR1:SWE:SPAC LIN" ' Linear sweep.
PRINT #1, "OUTPUT 25;:SOUR2:VOLT 5"    ' Detector 1 bias = 5V.
PRINT #1, "OUTPUT 25;:SOUR3:VOLT 5"    ' Detector 2 bias = 5V.
PRINT #1, "OUTPUT 25;:OUTP1 ON"        ' Turn on outputs.
CLS
PRINT #1, "OUTPUT 25;:READ?"           ' Trigger sweep and read data.
PRINT #1, "ENTER 25"                   ' Address 2520 to talk.
LINE INPUT #2, R$                       ' Input sweep data.
PRINT "Linear staircase sweep data: "; R$
PRINT #1, "OUTPUT 25;:OUTP1 OFF"      ' Turn off outputs.
END
```

List sweep program

The program listing below performs a list (custom) sweep as covered in [Section 7](#). This program sets up the following operating modes:

- Source mode: list sweep
- Source current range: 500mA
- Current list points: 200mA, 100mA, 400mA, 300mA, 500mA
- Pulse delay points: 7ms, 4ms, 2ms, 8ms, 1ms
- Pulse width points: 10 μ s, 50 μ s, 35 μ s, 20 μ s, 60 μ s
- Detector bias voltages: 5V

```
' Laser diode custom sweep program.
' 2520 primary address = 25.
OPEN "IEEE" FOR OUTPUT AS #1          ' Open IEEE-488 output path.
OPEN "IEEE" FOR INPUT AS #2          ' Open IEEE-488 input path.
PRINT #1, "INTERM CRLF"              ' Set input terminator.
PRINT #1, "OUTTERM LF"               ' Set output terminator.
PRINT #1, "REMOTE 25"                ' Put 2520 in remote.
PRINT #1, "OUTPUT 25;*RST"           ' Restore GPIB defaults.
PRINT #1, "OUTPUT 25;:FORM:ELEM VOLT1,CURR2,CURR3" ' Voltage/current data.
PRINT #1, "OUTPUT 25;:SOUR1:CURR:MODE LIST" ' Custom sweep mode.
PRINT #1, "OUTPUT 25;:SOUR1:LIST:CURR 0.2,0.1,0.4,0.3,0.5" ' I list.
PRINT #1, "OUTPUT 25;:SOUR1:LIST:DEL 7e-3,4e-3,2e-3,8e-3,1e-3" ' D list.
PRINT #1, "OUTPUT 25;:SOUR1:LIST:WIDT 10e-6,50e-6,35e-6,20e-6,60e-6"
PRINT #1, "OUTPUT 25;:SOUR2:VOLT 5"  ' Detector 1 bias = 5V.
PRINT #1, "OUTPUT 25;:SOUR3:VOLT 5"  ' Detector 2 bias = 5V.
PRINT #1, "OUTPUT 25;:OUTP1 ON"      ' Turn on outputs.
CLS
PRINT #1, "OUTPUT 25;:READ?"         ' Trigger sweep and read data.
PRINT #1, "ENTER 25"                 ' Address 2520 to talk.
LINE INPUT #2, R$                     ' Input sweep data.
PRINT "Custom sweep data: "; R$
PRINT #1, "OUTPUT 25;:OUTP1 OFF"     ' Turn off outputs.
END
```

Continuous Pulse Mode

Continuous pulse mode

In addition to LIV characterization, laser diodes typically require some type of wavelength or spectrum measurement. In these cases, the 2520 can be used as a current pulse generator, driving the laser diode with a current pulse train while a spectrometer or other instrument makes measurements. As a pulse generator, the 2520 provides a fixed pulse current level with control over pulse width and pulse off time to provide a desired duty cycle. As with conventional, single purpose pulse generators, no measurements are made when using the 2520 in the continuous pulse mode. Ensure that the 2520 is using the latest firmware (B07/DSP B06 as of this writing) before using the continuous pulse mode.

Pulse test advantage

Testing in the pulse regime is done to minimize the heating of the diode junction, so duty cycles are typically 1% or less. By minimizing the heating, testing can be performed on the laser diode as soon as the lasing cavity is defined, at the wafer level for VCSELs and at the bar level for edge-emitting laser diodes. This early testing permits pass/fail and other grading decisions to be performed before any additional process or packaging costs are added to the device.

Duty cycle

The 2520 supports a wide range of duty cycles. There are two different maximum duty cycles based on the current source level:

For $I \geq 1.00\text{A}$, Maximum Duty Cycle = 4%

For $I < 1.00\text{A}$, Maximum Duty Cycle = 99.6%

The duty cycle (DC) is controlled by adjusting the pulse width (PW) and pulse delay (PD) values. The pulse delay is the pulse off time. This gives:

$$\text{DC}\% = \frac{\text{PW}}{\text{PW} + \text{PD}} \times 100$$

where: DC = duty cycle (%)

PW = pulse width (s), 500ns to 5ms

PD = pulse delay (s), 20 μ s to 500ms

For example, the maximum duty cycle (for $I < 1\text{ A}$):

PW = 5ms

PD = 20 μ s

$$\text{DC}\% = \frac{5}{5.02} \times 100 = 99.6\%$$

Minimum Duty Cycle

$$PW = 500\text{ns}$$

$$PD = 500\text{ms}$$

$$DC\% = \frac{500 \times 10^{-9}}{0.5000005} \times 100 = 0.0001\%$$

Configuring the 2520 to use Continuous Pulse Mode

Front panel

Set up pulse mode and triggering:

1. Press CONFIG key, then TRIG.
2. Select INIT then press ENTER.
3. Select OFF then press ENTER.
4. The 2520 should be at the CONFIGURE TRIGGER MENU. Select COUNT then press ENTER.
5. Select CONTINUOUS-PULSE then press ENTER.
6. Press EXIT key to exit CONFIGURE TRIGGER MENU.

Set the desired Pulse Width:

1. Press the PW key.
2. Use the EDIT keys (◀▶▲▼) to set the desired pulse width. Press ENTER when finished.

Set the desired Pulse Delay (in other words Pulse off time):

1. Press the DELAY key.
2. Use the EDIT keys (◀▶▲▼) to set the pulse delay to 000.33ms. Press ENTER when finished.

Set the desired current source value:

1. Press the I_L key.
2. Use the EDIT keys (◀▶▲▼/) to set the desired current value. Press ENTER when finished.

To turn on the continuous pulse mode:

1. Press ON/OFF OUTPUT key to turn outputs on (blue OUTPUT indicator turns on).
2. Press the TRIG key. The 2520 is now outputting pulses, with the first line of the display reading, "Continuous Pulse."

To turn off the continuous pulse mode:

1. Press EXIT key.
2. Press ON/OFF OUTPUT key to turn outputs OFF.

Remote configuration over GPIB/IEEE-488

Command	Comment
*RST	Reset 2520
:SOUR1:CURREN:MODE FIX	Set source mode to FIXed (not sweep)
:SOUR1:CURREN 0.2	Set current pulse amplitude to 200mA
:SOUR1:PULS:DEL 0.00033	Set pulse delay (time between pulses) to 330µs
:SOUR1:PULS:WIDT 0.000001	Sets the pulse width to 1µs
:TRIG:COUN CONTINUOUS	Enables continuous pulsing mode
:OUTP ON	Turns Output ON
:SYST:KEY 20	Begins continuous pulsing
:SDC	Stops continuous pulsing*
:OUTP OFF	Turns Output OFF

* SDC — Selected Device Clear. SDC is a GPIB Bus Command (see Table 10-1). Implementing this command depends on the GPIB controller/driver. Refer to GPIB controlled documentation for specific syntax.

Example: For Keithley GPIB: transmit ("UNL LISTEN <addr> SDC", status)
 For NI GPIB: Dev Clear (<Boardnum>, <addr>)

Where: <addr> is the GPIB address of the 2520 and <Boardnum> is the GPIB controller board number, usually 0.

Related modes

There are three choices in the 2520 Trigger Count menu:

1. **Trigger count = Finite** — This mode will output up to 5000 pulses with a fixed source current. Measurements are taken at each pulse, which means that the minimum pulse delay time is about 2 milliseconds \pm 400µs. In addition, the minimum pulse delay is constrained by the maximum duty cycle of 4% above 1A source levels. This means that requesting a duty cycle > 4% will cause the pulse delay to be increased to give a duty cycle = 4%. For $I < 1A$, the maximum duty cycle is about 15%.
2. **Trigger count = Inf** — This mode will output an infinite stream of fixed current pulses. It is different from the Continuous Pulse mode because it offers measurements (VLD, Detector 1 current, Detector 2 current). The measurement process takes additional time, meaning that the minimum pulse delay time is about 2ms.
3. **Trigger count = Continuous Pulse** — This mode is explained above. It is similar to count = Inf, but there are no measurements in this mode and the set pulse width equals the actual pulse width.

Index

A

- Accessories 1-3
- Adapters 1-3
- Annunciators 1-7
 - LSTN 10-9
 - REM 10-9
 - SRQ 10-9
 - TALK 10-9

B

- Baud rate 10-16
- Bench defaults 8-5
- Bit size
 - Setting 14-48
- Buffer C-2
 - Configure sample buffer 14-57
 - Read sample buffer 14-56
- Bus management lines D-5
- Byte order 14-25

C

- Cable
 - Increasing length F-5
- Cable inductance F-3
- Cables
 - Interface 1-4
 - Signal 1-3
- Calculate subsystems 14-14
- Circuit configuration
 - Basic 3-5
 - Laser diode testing 4-3
- Command codes D-10
- Command reference
 - Calculate subsystems 14-14
 - DISPlay subsystem 14-17
 - FORMat subsystem 14-19
 - OUTPut subsystem 14-27
 - SENSe subsystem 14-27
 - SOURce subsystem 14-32
 - SOURce[1] 14-32
 - SOURce2 and SOURce3 14-46
 - SOURce4 14-47
 - STATus subsystem 14-49
 - SYSTem subsystem 14-51
 - TRACe subsystem 14-56
 - Trigger subsystem 14-57

- Command summary
 - CALCulate 14-3
 - DISPlay 14-5
 - FORMat 14-6
 - OUTPut 14-6
 - SENSe 14-7
 - SOURce 14-9
 - STATus 14-12
 - SYSTem 14-13
 - TRACe 14-13
 - TRIGger 14-14

Commands

- Address D-9
- Addressed multiline D-9
- Common see common commands 12-1
- Condition register 11-17
- Coupled E-4
- Custom sweep 7-10
- Error queue 11-21
- Event enable registers 11-18
- Event register 11-17
- Filter 6-5, 6-6
- General bus 10-6
- GPIB D-7
- Laser diode test 4-5
- Math functions 6-9
- Range 6-3
- Remote trigger 8-13
- Source and measure configuration 3-13
- Staircase sweep 7-8
- Status byte and service request 11-10
- Unaddress D-9
- Uniline D-8
- Universal multiline D-8

Common commands 12-1, D-10

- *IDN? 12-3
- *OPC 12-3
- *OPC? 12-3
- *OPT? 12-4
- *RCL 12-4
- *RST 12-5
- *SAV 12-4
- *TRG 12-5
- *TST? 12-6
- *WAI 12-6

Compliance

- Laser diode source 3-3

- Conductance (math function) 6-7

Configuration

- Buffer 14-57
- Circuit See Circuit configuration 3-5
- Detector 1-22
- Digital I/O port 9-2
- Digital output 9-3
- Filter 1-23, 6-5, 14-30
- GPIB D-4
- Laser diode current source 4-4
- Laser diode measurement function 4-4
- Laser diode measurements 3-12
- Laser diode source 3-10
- Laser diode voltage measurement 1-22
- MATH functions 1-24
- Math functions 4-5
- Measurements 3-12
- Menus 1-21
- Photodiode detector measurement functions 4-4
- Photodiode detector voltage bias sources 4-4
- Photodiode measurements 3-12
- Power-on 1-15
- Remote source and measure 3-13
- Source 3-9
- Sweep 7-5
- SWEEPS 1-24
- Sweeps 14-37
- Triggering 1-23, 8-7

Configuring the 2520 to use Continuous Pulse

- Mode I-3
- Front panel I-3

Connections

- Considerations 2-10
- GPIB 10-4
- IEEE-488 10-4
- Interlock 2-6
- Laser diode test 2-7
- Optimizing laser diode F-2
- Pulse sync output 9-9
- Remote interlock 2-6
- RS-232 10-18
- Sense lead F-8
- Testhead 2-3

Connectors

- CURRENT OUTPUT 2-6
- DETECTOR 1-9
- Digital I/O 1-8
- GPIB 1-8

- Laser diode 1-9
- MAINFRAME 1-10
- Pulse sync 1-8
- RS-232 1-8
- Signal 2-5
- TESTHEAD 1-8
- Triax DETECTOR 2-6
- Trigger link 1-8
- VOLTAGE SENSE 2-6

- Contact information 1-2
- Continuous pulse mode I-2
- Counter 8-4, 8-12
- Current pulse output circuit model F-2
- Current source
 - Limit lines 5-10
 - Operating boundaries 5-10
- Currents
 - Generated F-18
 - Offset F-19
- Custom sweeps 5-8, 7-4
 - Configure list 14-41
 - Waveform 5-9

D

- Data elements 14-22
 - Calculate 14-23
 - TRACe 14-24
- Data flow 5-12, C-1
- Data format 14-19
- Data lines D-5
- Data storage
 - Sweep 5-12
- DCL (device clear) 10-7
- Delay
 - Phase 5-3, 8-3, 8-12
- Delay-pulse cycle 5-2, 8-3, 8-12
- Delta (math function) 6-7
- Detector current
 - Select measurement range 14-28
- Dielectric absorption F-19
- Digital I/O port 1-8, 9-2
 - Configuration 9-2
- Digital output
 - Setting 14-47
- Digital output lines 9-2
 - Configuration 9-3
 - Controlling 9-4

Display

- Basic reading 5-12
- Control 14-17
- Example 1-13
- Format 1-13
- Front panel tests 1-14
- Math function 5-12
- Read 14-18
- Remote programming 1-14
- Units 1-13

DISPlay subsystem 14-17

DUT resistance F-17

Duty cycle 5-3, 1-2

E

Electromagnetic Interference (EMI) F-23

Electrostatic interference F-22

Equivalent circuit 2-8

Error and status messages 10-8

Error messages see Messages 1-13

Event detection 8-11

Examples

- *OPC programming example 12-4
- *SAV, *RCL programming example 12-5
- *TRG programming example 12-5
- Basic source and measure configuration programming example 3-14
- Custom sweep programming 7-10
- Display 1-13
- Filter programming example 6-6
- Laser diode test program H-3
- Laser diode test programming example 4-7
- Linear staircase sweep program H-4
- List sweep program H-5
- Math function programming example 6-10
- Program and read register set 11-19
- Programs H-1
- Range programming example 6-4
- Read error queue 11-21
- Remote trigger 8-14
- RS-232 programming example 10-20
- Staircase sweep programming 7-9
- Status byte programming example 11-10
- Sweep and list program examples 14-44

F

Factory default settings 1-15

Filter 6-4, 8-4, 8-12

Averaging 6-4

Commands 6-6

Configuration 6-5

Configure and control 14-30

Control 6-5

Programming example 6-6

Remote programming 6-5

Fixed mode

Front panel pulse parameters 5-4

Remote pulse parameters 5-6

Flow control see signal handshaking 10-17

FORMat subsystem 14-19

Front panel

Summary (mainframe) 1-6

Summary (testhead) 1-9

Front panel operation

Data flow 5-12

Digital output control 9-4

Display tests 1-14

GPIB 10-8

Laser diode test procedure 4-4

Laser diode testing 4-3

Math functions 6-8

Pulse parameters 5-4

Sweep 7-5

Trigger model 8-2

Fuse replacement 1-12

G

General information 1-2

General program instructions H-2

GET (group execute trigger) 10-8

Getting Started 1-1

GPIB

Configuration D-4

Connections 10-4

Connector 1-8

Defaults 8-13

Front panel operation 10-8

General bus commands 10-6

Operation 10-3

Overview D-1

Standards 10-3

Status indicators 10-9

GPIB 488.1 Protocol G-1
GPIB commands D-7
GPIB description D-2
Ground loops F-20
GTL (go to local) 10-7

H

Handshake lines D-5
Hardware requirements H-2

I

Idle 8-9
Idle layer 8-3
IEEE-488
 Bus see GPIB D-1
 Connector 10-4
 Documentation requirements E-3
 Multi-unit test system connections 10-4
IFC (interface clear) 10-7
Indicator lights 1-10
Initiate 8-9
Input triggers 8-3, 8-11
 Specifications 8-6
Inspection 1-3
Interface function codes D-14
Interlock 1-10, 9-5
 Connections 2-6
 Key 2-7
 Operation 9-6
 Reading state 9-7
 Status 14-27
 Status indicator test sequence 9-7

K

Key interlock 2-7
Keys
 COMPL 1-6
 DETECTOR 1 1-6
 DETECTOR 2 1-6
 EDIT 1-6
 LASER 1-6
 LOCAL 10-9
 Operation 1-7
 RANGE 1-6
 Simulate key presses 14-53

L

Laser diode
 Configuring measurements 3-12
 Configuring source 3-10
 Current source 4-4
 Current source ranges 3-2, 6-3
 Front panel test procedure 4-4
 Front panel testing 4-3
 Impedance matching F-12
 Math function 14-15
 Measurement function 4-4
 Optimizing connections F-2
 Polarity 3-6
 Remote testing 4-5
 Select laser diode voltage measurement range 14-28
 Source and measure capabilities 3-2
 Source compliance 3-3
 Test circuit configuration 4-3
 Test commands 4-5
 Test connections 2-7
 Testing 4-1
 Voltage measurement ranges 3-3
 Voltage ranges 6-2
Light F-21
Limit lines 5-10
Limits
 Query voltage 14-29
 Set voltage limit 14-35
Line fuse 1-12
Line power connection 1-11
Line voltage 1-11
Linear staircase sweep 7-2, 14-44
 Performing 7-6
List sweep 14-44
LLO (local lockout) 10-7
Loading effects 5-10
LOCAL key 10-9
Logarithmic staircase sweep 7-3, 14-45
 Performing 7-7
Loop area F-6

M

- Magnetic coupling F-10
- Magnetic fields F-22
- Mainframe front panel 1-6
- Mainframe rear panel 1-8
- Math function
 - Display 5-12
- Math functions 6-6
 - Commands 6-9
 - Conductance 6-7
 - Delta 6-7
 - Front panel 6-8
 - Laser diode 14-15
 - MX + B 6-7
 - Power 6-7
 - Programming 6-8
 - Programming example 6-10
 - Remote 6-9
 - Resistance 6-7
- Measurement
 - Considerations F-1
 - General considerations F-20
 - Math functions 6-6
 - Ranges 6-2
- Measurements
 - Configuration 3-12
- Menus
 - COMM 1-20
 - COMPL 1-21
 - Configuration 1-21
 - CONFIGURE TRIGGER 8-7
 - DELAY 1-21
 - DETECTOR configuration 1-22
 - DIG OUT 1-20
 - FILTER configuration 1-23
 - LASER configuration 1-22
 - Main 1-18
 - Main operation 1-19
 - MATH configuration 1-24, 6-8
 - PW 1-21
 - Rules to navigate 1-18
 - SETUP 1-20
 - Source and measure configuration 4-2
 - SWEEP configuration 1-24
 - TRIG configuration 1-23
- Messages
 - Define
 - TEXT 14-18
 - Error and status 10-8
 - Status and error 1-13, B-1
- MX + B (math function) 6-7
 - Set parameters 14-15

N

- Noise Source
 - Impedance F-17

O

- Operating boundaries see Limit lines 5-10
- Operation overview 3-2
- Options 1-3
- Output circuit model F-13
- OUTPut subsystem 14-27
- Output trigger 8-4
 - Specifications 8-6
- Output triggers 8-13

P

- Parameters
 - Front panel pulse 5-4
 - Remote pulse 5-6
- Photodiode
 - Configuring measurements 3-12
 - Current measurement ranges 3-4, 6-2
 - Detector measurement functions 4-4
 - Detector voltage bias source 4-4
 - Source and measure capabilities 3-3
- Photodiode current measurement circuit model F-16
- Polarity
 - Considerations 2-8
 - Detector measurement 3-8
 - Laser diode 3-6
 - Select 14-29
 - Select source polarity 14-35
 - Voltage bias 3-8
- Power (math function) 6-7
- Power module 1-8
- Power-on
 - Configuration 1-15
- Power-up 1-11
 - Sequence 1-11
- Primary address 10-6
- Product overview 1-5
- Programming Examples
 - Set MSS (B6) when error occurs 11-10
- Programming syntax 10-10
- Pulse
 - Characteristics 5-7
 - Concepts 5-2
 - Front panel parameters 5-4
 - Phase 5-3
 - Remote parameters 5-6
 - Rise and fall times 5-7

Pulse phase 8-4, 8-12
Pulse sync output 9-8
 Connections 9-9
 Waveform 9-8
Pulse test advantage I-2

Q

Queues 11-2, 11-19
 Clearing 11-4
 Error 11-20, 14-52
 Output 11-19

R

Rack mount kits 1-4
Range 6-2
 Commands 6-3
 Programming example 6-4
 Remote programming 6-3
 Select source range 14-33
 Setting the measurement range 6-3
 Source ranging 6-3
Readings
 Acquiring 13-2
Rear panel
 Summary (mainframe) 1-7
 Summary (testhead) 1-10
Registers
 Bit descriptions 11-11
 Clearing 11-4
 Condition registers 11-17
 Error 14-50
 Event enable registers 11-18
 Event registers 11-17
 Measurement event register 11-14
 Operation event register 11-13
 Program event enable registers 14-49
 Programming enable registers 11-5
 Questionable event register 11-16
 Read condition registers 14-50
 Read event registers 14-49
 Reading 11-6
 Select default conditions 14-50
 Service request enable register 11-8
 Standard event register 11-11
 Status byte register 11-8
 Status register sets 11-11
Related modes I-4
Remote configuration over GPIB/IEEE-488 I-4

Remote operation 10-1
 Differences to local operation 10-2
 Selecting an interface 10-2
 Trigger model 8-9
Remote programming
 Digital output control 9-5
 Display 1-14
 Filter 6-5
 Laser diode testing 4-5
 Math functions 6-9
 Pulse parameters 5-6
 Range 6-3
 Setups 1-17
 Sweeps 7-8
 Trigger commands 8-13
REN (remote enable) 10-7
Resistance (math function) 6-7
RS-232
 Connector 1-8
RS-232 interface 10-2, 14-55
 Connections 10-18
 Connector 10-18
 Data bits and parity 10-17
 Operation 10-16
 Sending and receiving data 10-16

S

Safety
 Symbols and terms 1-2
SCPI
 Command reference 14-1
 Eliminating common errors B-7
 Reference tables 14-2
SCPI commands D-10
SCPI commands see Command reference,
 Command summary, Common
 commands, and Signal-oriented
 measurement commands 14-1
SCPI conformance information E-1
SDC (selective device clear) 10-8
SENSe subsystem 14-27
Serial polling 11-9
Settings
 Factory default 1-15
Setups
 Remote 1-17
 Restoring 1-15
 Saving 1-14

Signal handshaking 10-17
Signal-oriented measurement commands 13-1
[:SENSe[1]]:DATA[:LATest]? 13-3
[:SENSe2]:DATA[:LATest]? 13-3
[:SENSe3]:DATA[:LATest]? 13-3
FETCh? 13-2
MEASure? 13-3
READ? 13-3
Sink operation 9-3
Software requirements H-2
Source
 Capacitance F-18
 Configuration 3-9
 Control outputs on-off 14-32
 Editing values 3-9
 Select function 14-33
 Select mode 14-32
 Select polarity 14-35
 Select range 14-33
 Set amplitudes 14-34, 14-47
 Set pulse times 14-36
Source memory
 Sweep configuration 7-5
Source operation 9-4
SOURce subsystem 14-32
Source values
 Setting photodiode detector 3-11
Source/measure cycle
 Abort 14-58
 Initiate 14-57
Source-measure
 Concepts 5-1
SPE, SPD (serial polling) 10-8, 11-9
Specifications and accessories A-1
Speed
 Increasing laser diode pulse
 measurement F-11
Staircase sweeps 5-8
 Mode (front panel pulse parameters) 5-4
 Mode (remote pulse parameters) 5-6
Start-of-test (SOT) line 9-3
Status and error messages 1-13, B-1
Status byte and SRQ 11-2, 11-7
 Commands 11-10
Status register format 14-26
Status register sets 11-2, 11-11
Status structure 11-1
STATus subsystem 14-49

Sweep
 Averaging filter during 6-5
 Configure 14-37
 Configuring 7-5
 Custom 5-8, 7-4
 Custom sweep commands 7-10
 Custom waveform 5-9
 Data storage 5-12
 Front panel operation 7-5
 Linear staircase 7-2
 Logarithmic staircase 7-3
 Performing 7-6
 Points 8-4, 8-12
 Program examples 14-44
 Remote operation 7-8
 Staircase 5-8
 Staircase commands 7-8
 Types 5-8, 7-2
 Waveforms 5-8
Sweep Operation 7-1
Sweeps
 Staircase 5-4, 5-6
Syntax 10-10
System identification 1-12
SYSTEM subsystem 14-51

T

Terminator 10-17
Testhead
 Connections 2-3
 Mounting 2-3
 Signal connectors 2-5
Testhead front panel 1-9
Testhead rear panel 1-10
Tests
 Front panel display 1-14
 Front panel laser diode 4-3
 Laser diode 4-1
 Remote laser diode 4-5
Timestamp
 Reset 14-55
TRACe subsystem 14-56
Transmission line model F-14
Trigger link 8-5
 Connector 1-8
Trigger model
 Program 14-58

Trigger subsystem 14-57
Triggering 8-1
 Configuring 8-7
 Front panel operation 8-2
 Remote 8-9
Triggers
 Input 8-3, 8-6, 8-11
 Output 8-13

U

User setups see Setups 1-14

V

Voltage
 Burden F-20
Voltage measurement circuit model F-15

W

Warranty information 1-2



Equipment .NET

An Interworld Highway, LLC Company

Specifications are subject to change without notice.

All Keithley trademarks and trade names are the property of Keithley Instruments, Inc.
All other trademarks and trade names are the property of their respective companies.

KEITHLEY

Keithley Instruments, Inc.

28775 Aurora Road • Cleveland, Ohio 44139 • 440-248-0400 • Fax: 440-248-6168
1-888-KEITHLEY (534-8453) • www.keithley.com

Sales Offices:

BELGIUM:	Bergensesteenweg 709 • B-1600 Sint-Pieters-Leeuw • 02-363 00 40 • Fax: 02/363 00 64
CHINA:	Yuan Chen Xin Building, Room 705 • 12 Yumin Road, Dewai, Madian • Beijing 100029 • 8610-8225-1886 • Fax: 8610-8225-1892
FINLAND:	Tietäjantie 2 • 02130 Espoo • Phone: 09-54 75 08 10 • Fax: 09-25 10 51 00
FRANCE:	3, allée des Garays • 91127 Palaiseau Cédex • 01-64 53 20 20 • Fax: 01-60 11 77 26
GERMANY:	Landsberger Strasse 65 • 82110 Germering • 089/84 93 07-40 • Fax: 089/84 93 07-34
GREAT BRITAIN:	Unit 2 Commerce Park, Brunel Road • Theale • Berkshire RG7 4AB • 0118 929 7500 • Fax: 0118 929 7519
INDIA:	1/5 Eagles Street • Langford Town • Bangalore 560 025 • 080 212 8027 • Fax: 080 212 8005
ITALY:	Viale San Gimignano, 38 • 20146 Milano • 02-48 39 16 01 • Fax: 02-48 30 22 74
JAPAN:	New Pier Takeshiba North Tower 13F • 11-1, Kaigan 1-chome • Minato-ku, Tokyo 105-0022 • 81-3-5733-7555 • Fax: 81-3-5733-7556
KOREA:	2FL., URI Building • 2-14 Yangjae-Dong • Seocho-Gu, Seoul 137-888 • 82-2-574-7778 • Fax: 82-2-574-7838
NETHERLANDS:	Postbus 559 • 4200 AN Gorinchem • 0183-635333 • Fax: 0183-630821
SWEDEN:	c/o Regus Business Centre • Frosundaviks Allé 15, 4tr • 169 70 Solna • 08-509 04 600 • Fax: 08-655 26 10
TAIWAN:	13F-3. No. 6, Lane 99 Pu-Ding Road • Hsinchu, Taiwan, R.O.C. • 886-3-572-9077 • Fax: 886-3-572-9031